

DRAWING FOR REFERENCE: This is subject to change without notice
05/31/2013

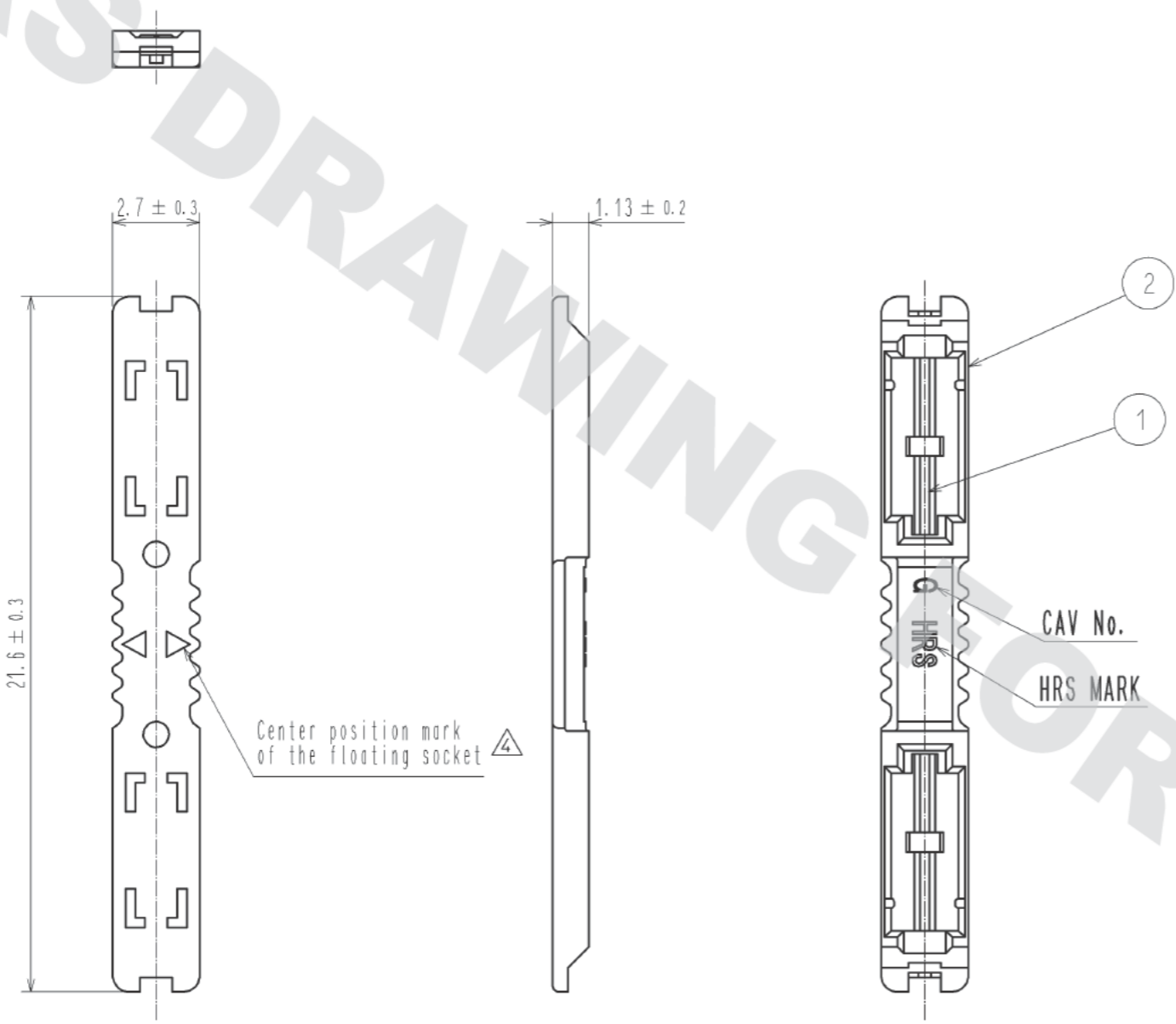

NOTE1. REFER TO THE DF59S SERIES MATING/UNMATING OPERATION INSTRUCTION MANUAL (ETAD-H0651) FOR THE OPERATING OF THE PRODUCT.

NO.	MATERIAL	FINISH . REMARKS	NO.	MATERIAL	FINISH . REMARKS
2	LCP	UL94V-0. BEIGE	5	PS	REEL. BLACK
1	BRASS	SURFACE:TIN PLATING 1 μ m MIN UNDER PLATING:Cu PLATING 0.3 μ m MIN	4	POLYESTER	CLEAR(COVER TAPE)
			3	PS	CLEAR(EMBOSSED CARRIER TAPE)

UNITS	SCALE	COUNT	DESCRIPTION OF REVISIONS	DESIGNED	CHECKED	DATE
mm	5 : 1	1	DIS-H-007568	MI. SAKIMURA	TS. KUMAZAWA	13. 01. 23

HRS HIROSE ELECTRIC CO., LTD.	APPROVED : KI. AKIYAMA	12. 06. 21	DRAWING NO.	EDC3-342886-01
	CHECKED : OM. MIYAMOTO	12. 06. 21	PART NO.	DF59S-1P-FC(21)
	DESIGNED : KT. ISHII	12. 06. 21	CODE NO.	CL667-0023-3-21
	DRAWN : KT. ISHII	12. 06. 21		

DRAWING FOR REFERENCE: This is subject to change without notice
05/31/2013

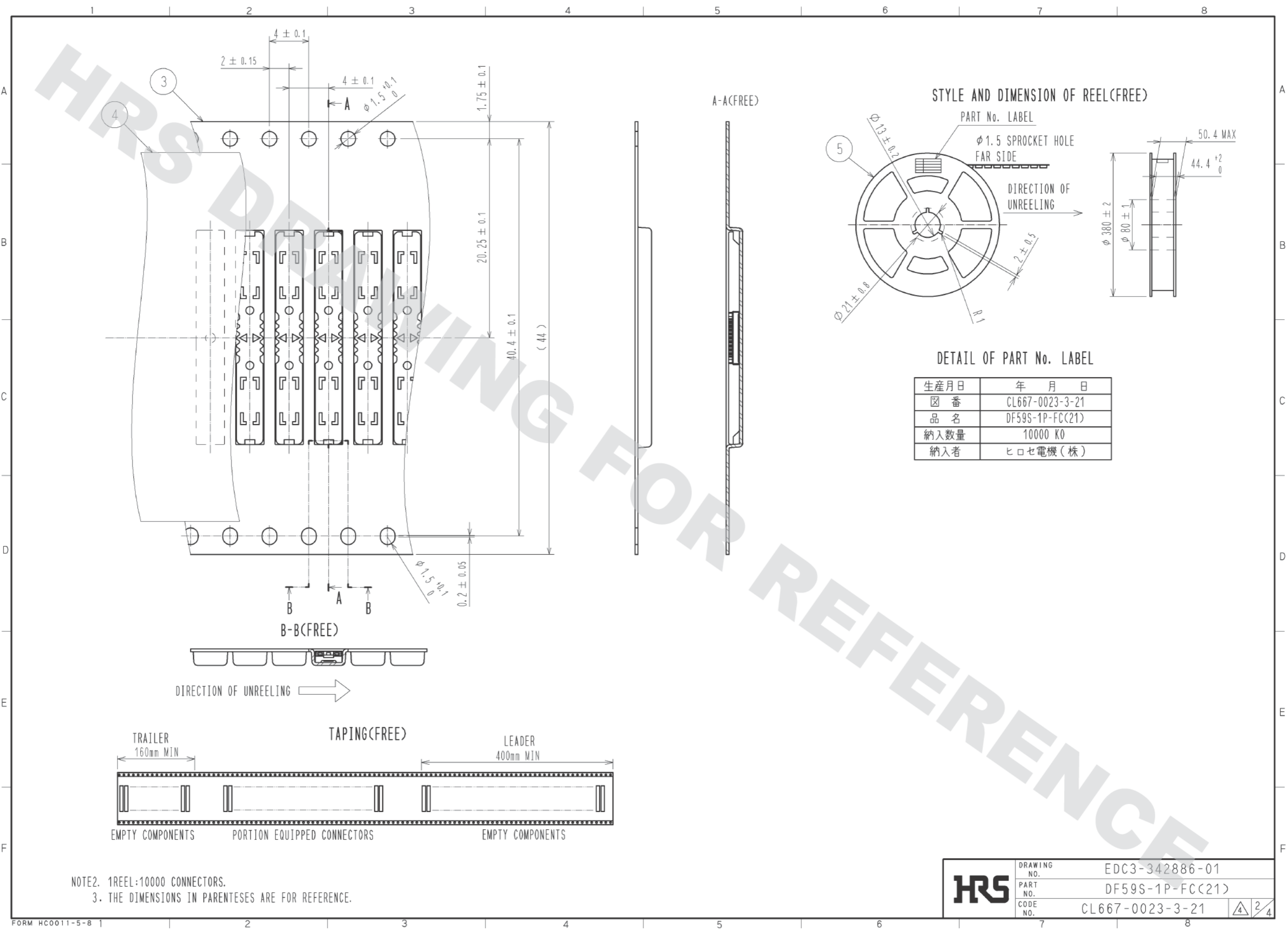

NOTE2. 1REEL:10000 CONNECTORS.
3. THE DIMENSIONS IN PARENTESES ARE FOR REFERENCE.

HRS	DRAWING NO.	EDC3-342886-01
	PART NO.	DF59S-1P-FC(21)
	CODE NO.	CL667-0023-3-21
		2/4

DF59S Operation Procedures for Floating Socket

«Mating»

1. Place the floating socket at the tip on the receptacle mating point.

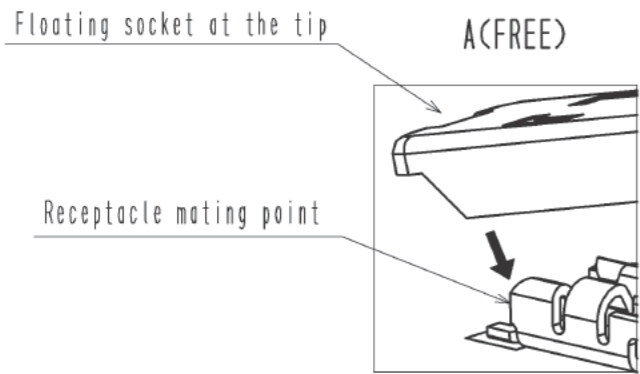
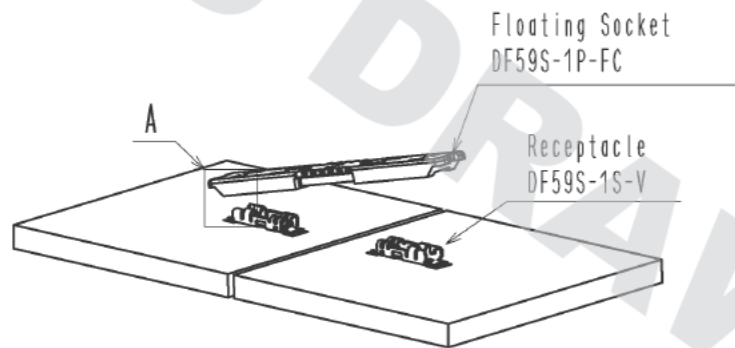

※Floating socket can be mating both directions.

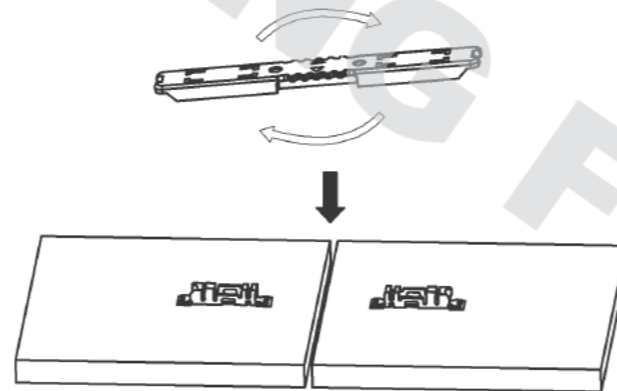

2. Align the center position of floating socket to the center position of the clearance between the facing PCBs in a line.

Press down at the center surface of the floating socket.

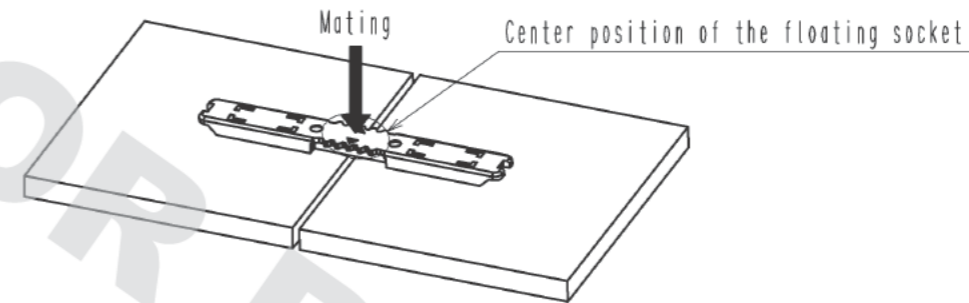
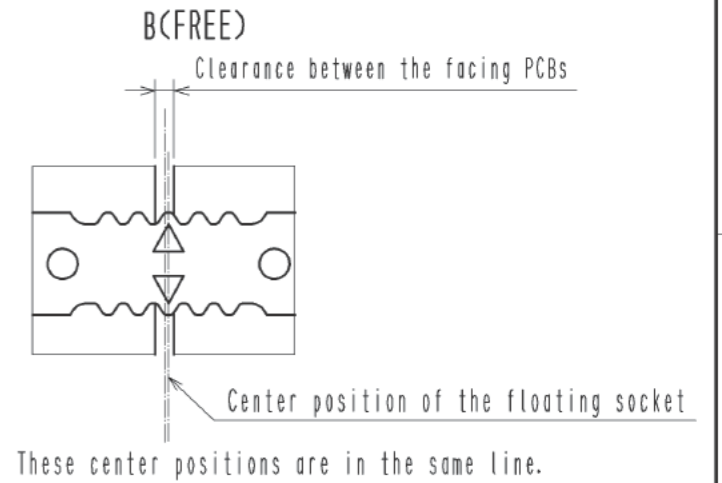
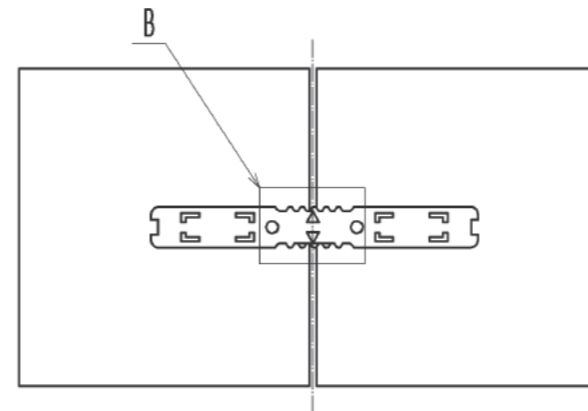

«Unmating»

1. Hook the lever on either sides of floating socket with finger and lift up to the upper direction for unlock. (Lift up until friction lock is released.)

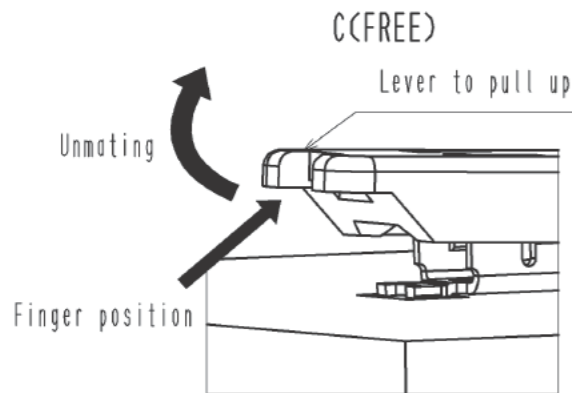
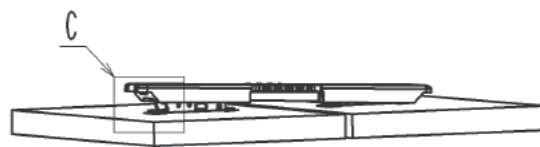

2. After releasing either side, hook the lever on the other side with a finger and lift up to the upper direction, too.

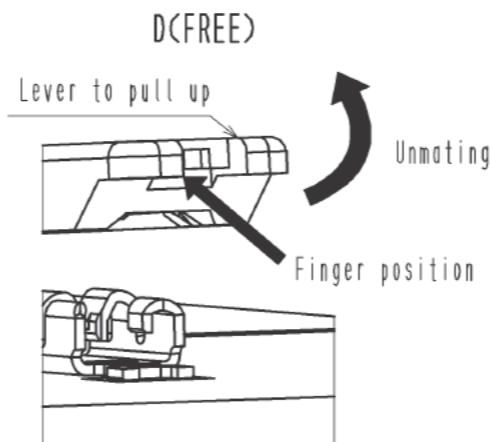
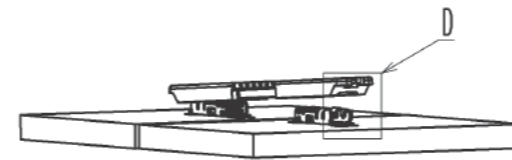

HRS	DRAWING NO.	EDC3-342886-01
	PART NO.	DF59S-1P-FC(21)
	CODE NO.	CL667-0023-3-21
		3/4

DF59S Dimension of floating

The dimension of floating at the time of using a floating socket is shown below.
Please use in the limits of dimension.

《Direction of X axis》

The dimension of floating of X direction is shown below.

Direction of X axis floating: +0.5mm
 Normal mating
 Direction of X axis floating: -0.5mm

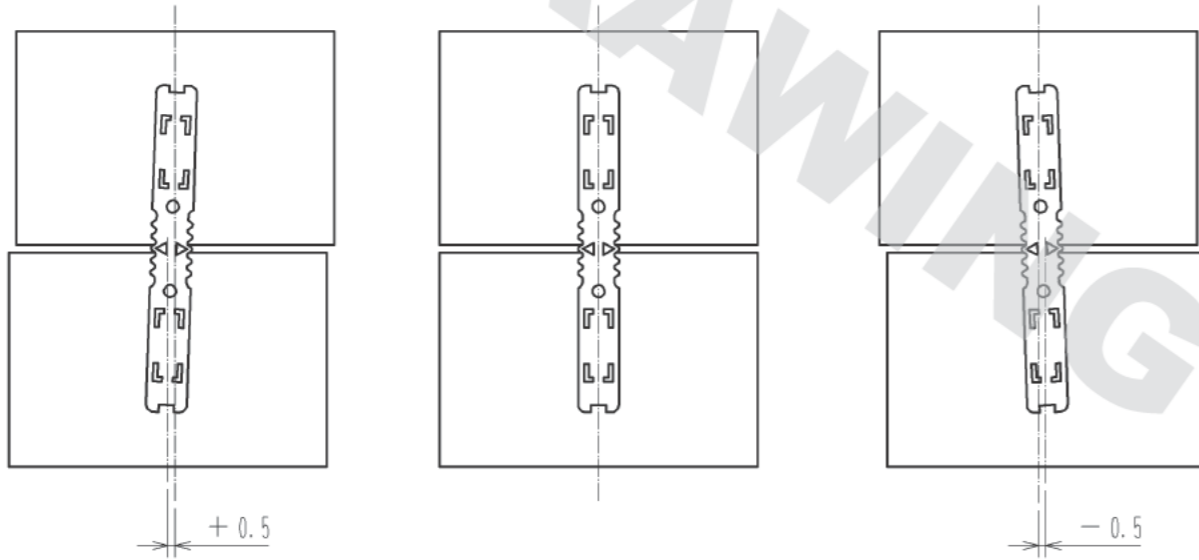

《Direction of Y axis》

The dimension of floating of Y direction is shown below.

Direction of Y axis floating: +0.5mm
 Normal mating
 Direction of Y axis floating: -0.5mm

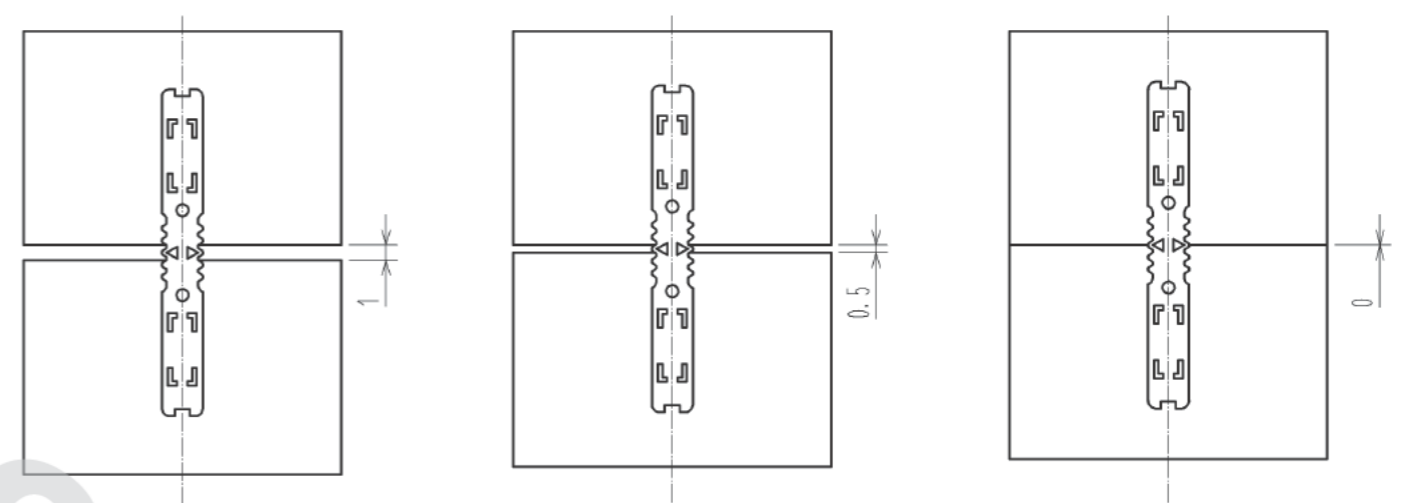

《Direction of Z axis》

The dimension of floating of Z direction is shown below.

Direction of Z axis floating: +0.2mm
 Normal mating
 Direction of Z axis floating: -0.2mm

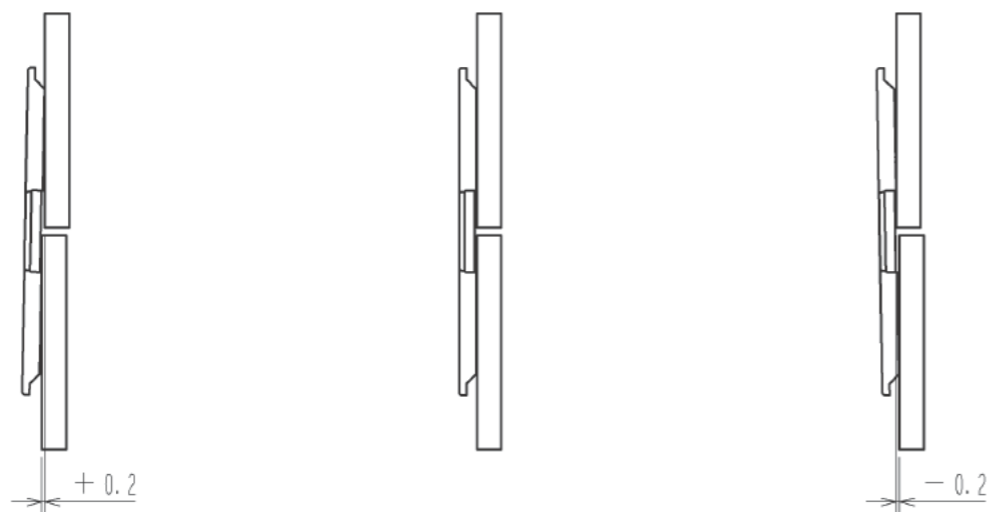

HRS

図番: EDC3-342886-01
 製品名: DF59S-1P-FC(21)
 製品コード: CL667-0023-3-21

4/4

DRAWING FOR REFERENCE: This is subject to change without notice
05/31/2013