

---

**I<sup>2</sup>C-Compatible (2-wire) Serial EEPROM**  
**1-Mbit (131,072 x 8)**

---

**DATASHEET**

---

**Features**

---

- Low Voltage and Standard Voltage Operation Available
  - 1.7V ( $V_{CC} = 1.7V$  to 5.5V)
  - 2.5V ( $V_{CC} = 2.5V$  to 5.5V)
- Internally Organized 131,072 x 8
- 2-wire Serial Interface
- Schmitt Triggers, Filtered Inputs for Noise Suppression
- Bidirectional Data Transfer Protocol
- 400kHz (1.7V) and 1MHz (5V, 2.5V) Compatibility
- Write Protect Pin for Hardware Data Protection
- 256-byte Page Write Mode
  - Partial Page Writes Allowed
- Random and Sequential Read Modes
- Self-timed Write Cycle (5ms Max)
- High Reliability
  - Endurance: 1,000,000 Write Cycles
  - Data Retention: 40 Years
- Green Package Options (Pb/Halide-free/RoHS Compliant)
  - 8-lead JEDEC SOIC, 8-lead EIAJ SOIC, 8-lead TSSOP, and 8-ball WLCSP
- Die Sale Options: Wafer Form and Tape and Reel Available

---

**Description**

---

The Atmel® AT24CM01 provides 1,048,576 bits of Serial Electrically Erasable and Programmable Read-Only Memory (EEPROM) organized as 131,072 words of 8 bits each. The device's cascadable feature allows up to four devices to share a common 2-wire bus. The device is optimized for use in many industrial and commercial applications where low power and low voltage operation are essential. The devices are available in space-saving 8-lead JEDEC SOIC, 8-lead EIAJ SOIC, 8-lead TSSOP, and 8-ball WLCSP. In addition, the entire family is available in 1.7V (1.7V to 5.5V) and 2.5V (2.5V to 5.5V) versions.

## 1. Pin Configurations and Pinouts

Pin Name	Function
NC	No Connect
A <sub>1</sub>	Address Input
A <sub>2</sub>	Address Input
GND	Ground
SDA	Serial Data
SCL	Serial Clock Input
WP	Write Protect
V <sub>CC</sub>	Power Supply

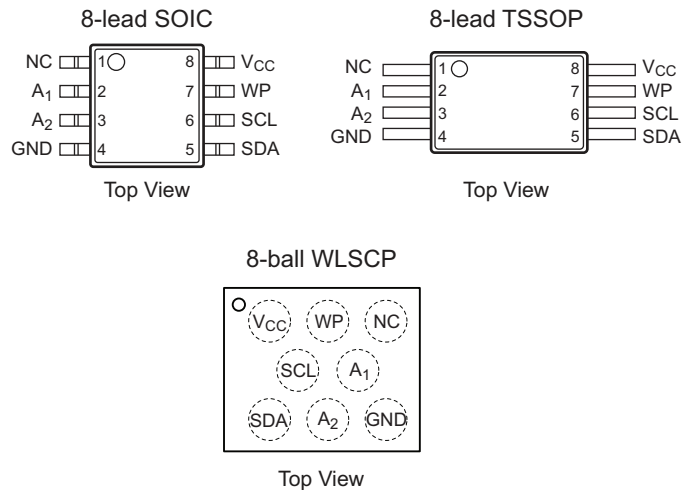

Note: Drawings are not to scale.

## 2. Absolute Maximum Ratings\*

Operating Temperature . . . . .	-55°C to +125°C
Storage Temperature . . . . .	-65°C to +150°C
Voltage on any pin with respect to ground . . . . .	-1.0V to +7.0V
Maximum Operating Voltage . . . . .	6.25V
DC Output Current . . . . .	5.0mA

\*Notice: Stresses beyond those listed under "Absolute Maximum Ratings" may cause permanent damage to the device. This is a stress rating only and functional operation of the device at these or any other conditions beyond those indicated in the operational sections of this specification is not implied. Exposure to absolute maximum rating conditions for extended periods may affect device reliability.

### 3. Block Diagram



### 4. Pin Description

**Serial Clock (SCL):** The SCL input is used to positive edge clock data into each EEPROM device and negative edge clock data out of each device.

**Serial Data (SDA):** The SDA pin is bidirectional for serial data transfer. This pin is open drain driven and may be wire-ORed with any number of other open drain or open collector devices.

**Device Addresses (A<sub>2</sub> and A<sub>1</sub>):** The A<sub>2</sub> and A<sub>1</sub> pins are device address inputs that can be hardwired or left not connected for hardware compatibility with other Atmel AT24Cxx devices. When the A<sub>2</sub> and A<sub>1</sub> pins are hardwired, as many as four 1-Mbit devices may be addressed on a single bus system (See “Device Addressing” on page 9. for more details). If the A<sub>2</sub> and A<sub>1</sub> pins are left floating, the A<sub>2</sub> and A<sub>1</sub> pin will be internally pulled down to GND if the capacitive coupling to the circuit board V<sub>CC</sub> plane is <3pF. If coupling is >3pF, Atmel recommends connecting the A<sub>2</sub> and A<sub>1</sub> pin to GND.

**Write Protect (WP):** The Write Protect input, when connected to GND, allows normal write operations. When WP is connected high to V<sub>CC</sub>, all write operations to the memory are inhibited. If the pin is left floating, the WP pin will be internally pulled down to GND if the capacitive coupling to the circuit board V<sub>CC</sub> plane is <3pF. If coupling is >3pF, Atmel recommends connecting the pin to GND. Switching WP to V<sub>CC</sub> prior to a write operation creates a software write protect function.

Table 4-1. Write Protect

WP Pin Status	Part of the Array Protected
At V <sub>CC</sub>	Full Array
At GND	Normal Read/Write Operations

## 5. Memory Organization

**AT24CM01, 1-Mbit Serial EEPROM:** The 1-Mbit is internally organized as 512 pages of 256 bytes each. Random word addressing requires a 17-bit data word address.

### 5.1 Pin Capacitance

**Table 5-1. Pin Capacitance<sup>(1)</sup>**

Applicable over recommended operating range from  $T_A = 25^\circ\text{C}$ ,  $f = 1.0\text{MHz}$ ,  $V_{CC} = 5.5\text{V}$ .

Symbol	Test Condition	Max	Units	Conditions
$C_{I/O}$	Input/Output Capacitance (SDA)	8	pF	$V_{I/O} = 0\text{V}$
$C_{IN}$	Input Capacitance ( $A_2$ , $A_1$ , SCL)	6	pF	$V_{IN} = 0\text{V}$

Note: 1. This parameter is characterized and is not 100% tested.

### 5.2 DC Characteristics

**Table 5-2. DC Characteristics**

Applicable over recommended operating range from:  $T_{AI} = -40^\circ\text{C}$  to  $+85^\circ\text{C}$ ,  $V_{CC} = 1.7\text{V}$  to  $5.5\text{V}$  (unless otherwise noted).

Symbol	Parameter	Test Condition		Min	Typ	Max	Units
$V_{CC1}$	Supply Voltage, 1.7V Option			1.7		5.5	V
$V_{CC2}$	Supply Voltage, 2.5V Option			2.5		5.5	V
$I_{CC}$	Supply Current	$V_{CC} = 5.0\text{V}$	Read at 400kHz			2.0	mA
$I_{CC}$	Supply Current	$V_{CC} = 5.0\text{V}$	Write at 400kHz			3.0	mA
$I_{SB}$	Standby Current	$V_{CC} = 1.7\text{V}$	$V_{IN} = V_{CC}$ or $V_{SS}$			1.0	$\mu\text{A}$
		$V_{CC} = 2.5\text{V}$				2.0	$\mu\text{A}$
		$V_{CC} = 3.6\text{V}$	$V_{IN} = V_{CC}$ or $V_{SS}$			3.0	$\mu\text{A}$
		$V_{CC} = 5.5\text{V}$				6.0	$\mu\text{A}$
$I_{LI}$	Input Leakage Current	$V_{IN} = V_{CC}$ or $V_{SS}$			0.10	3.0	$\mu\text{A}$
$I_{LO}$	Output Leakage Current	$V_{OUT} = V_{CC}$ or $V_{SS}$			0.05	3.0	$\mu\text{A}$
$V_{IL}$	Input Low Level <sup>(1)</sup>			-0.6		$V_{CC} \times 0.3$	V
$V_{IH}$	Input High Level <sup>(1)</sup>			$V_{CC} \times 0.7$		$V_{CC} + 0.5$	V
$V_{OL1}$	Output Low Level	$V_{CC} = 1.7\text{V}$	$I_{OL} = 0.15\text{mA}$			0.2	V
$V_{OL2}$	Output Low Level	$V_{CC} = 3.0\text{V}$	$I_{OL} = 2.1\text{mA}$			0.4	V

Note: 1.  $V_{IL}$  min and  $V_{IH}$  max are reference only and are not tested.

## 5.3 AC Characteristics

**Table 5-3. AC Characteristics**

Applicable over recommended operating range from  $T_{AI} = -40^{\circ}\text{C}$  to  $+85^{\circ}\text{C}$ ,  $V_{CC} = 1.7\text{V}$  to  $5.5\text{V}$  (where applicable),  $CL = 100\text{pF}$  (unless otherwise noted). Test conditions are listed in [Note 2](#).

Symbol	Parameter	1.7V		2.5V, 5.0V		Units
		Min	Max	Min	Max	
$f_{SCL}$	Clock Frequency, SCL		400		1000	kHz
$t_{LOW}$	Clock Pulse Width Low	1300		400		ns
$t_{HIGH}$	Clock Pulse Width High	600		400		ns
$t_I$	Noise Suppression Time <sup>(1)</sup>		100		50	ns
$t_{AA}$	Clock Low to Data Out Valid	50	900	50	550	ns
$t_{BUF}$	Time the bus must be free before a new transmission can start <sup>(1)</sup>	1300		500		ns
$t_{HD.STA}$	Start Condition Hold Time	600		250		ns
$t_{SU.STA}$	Start Condition Set-up Time	600		250		ns
$t_{HD.DAT}$	Data In Hold Time	0		0		ns
$t_{SU.DAT}$	Data In Set-up Time	100		100		ns
$t_R$	Inputs Rise Time <sup>(1)</sup>		300		300	ns
$t_F$	Inputs Fall Time <sup>(1)</sup>		300		100	ns
$t_{SU.STO}$	Stop Condition Set-up Time	600		250		ns
$t_{DH}$	Data Out Hold Time	50		50		ns
$t_{WR}$	Write Cycle Time		5		5	ms
Endurance <sup>(1)</sup>	25°C, Page Mode, 3.3V	1,000,000				Write Cycles

- Notes:
- This parameter is ensured by characterization only.
  - AC measurement conditions:
    - $R_L$  (connects to  $V_{CC}$ ): 1.3 k $\Omega$  (2.5V, 5V), 10 k $\Omega$  (1.7V)
    - Input pulse voltages: 0.3  $V_{CC}$  to 0.7  $V_{CC}$
    - Input rise and fall times:  $\leq 50\text{ns}$
    - Input and output timing reference voltages: 0.5  $V_{CC}$

## 6. Device Operation

**Clock and Data Transitions:** The SDA pin is normally pulled high with an external device. Data on the SDA pin may change only during SCL low time periods. Data changes during SCL high periods will indicate a Start or Stop condition as defined below.

**Figure 6-1. Data Validity**

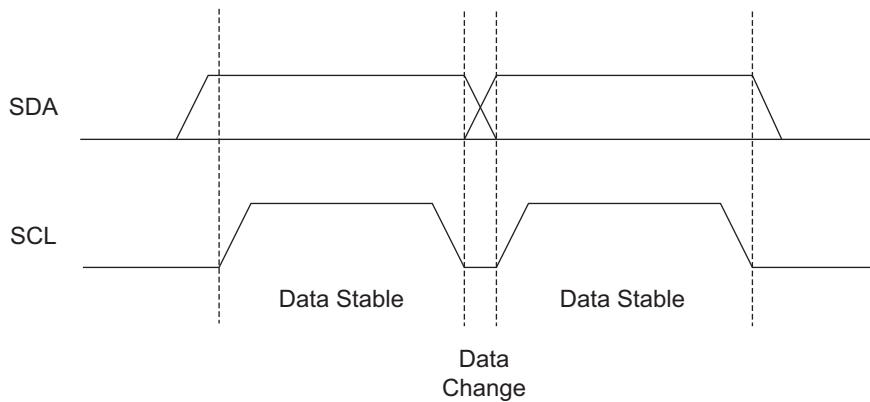

**Start Condition:** A high-to-low transition of SDA with SCL high is a Start condition which must precede any other command.

**Stop Condition:** A low-to-high transition of SDA with SCL high is a Stop condition. After a read sequence, the Stop condition will place the EEPROM in a standby power mode.

**Figure 6-2. Start and Stop Definition**

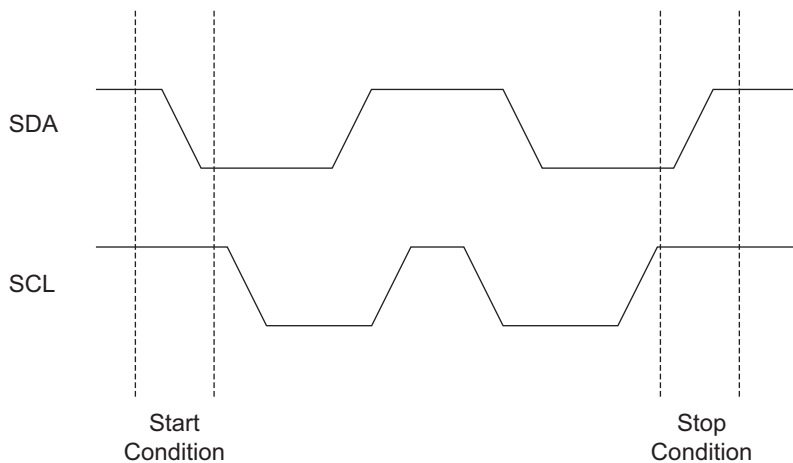

**Acknowledge:** All addresses and data words are serially transmitted to and from the EEPROM in eight bit words. The EEPROM sends a zero during the ninth clock cycle to acknowledge that it has received each word.

**Figure 6-3. Output Acknowledge**

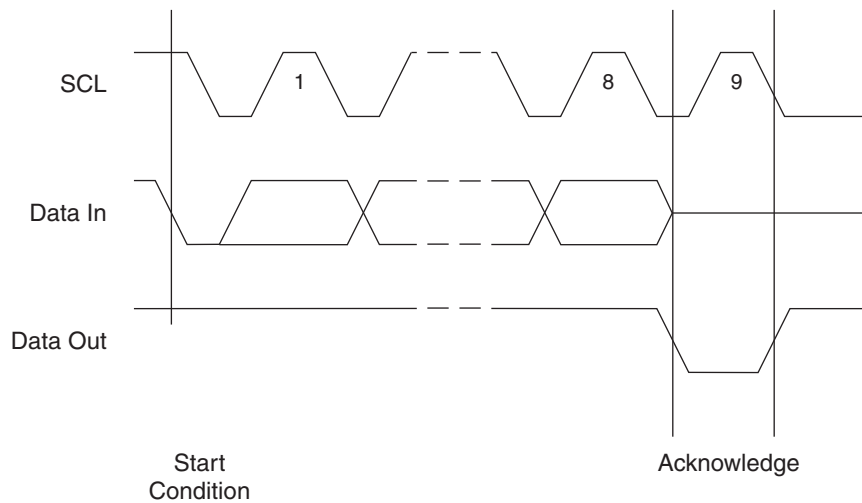

**Standby Mode:** The AT24CM01 features a low-power standby mode which is enabled:

- Upon power-up.
- After the receipt of the Stop condition and the completion of any internal operation.

**Software Reset:** After an interruption in protocol, power loss, or system reset, any 2-wire part can be protocol reset by following these steps:

1. Create a Start condition (if possible).
2. Clock nine cycles.
3. Create another Start condition followed by Stop condition as in [Figure 6-4](#).

The device should be ready for the next communication after the above steps have been completed. In the event that the device is still non-responsive or remains active on the SDA bus, a power cycle must be used to reset the device.

**Figure 6-4. Software Reset**

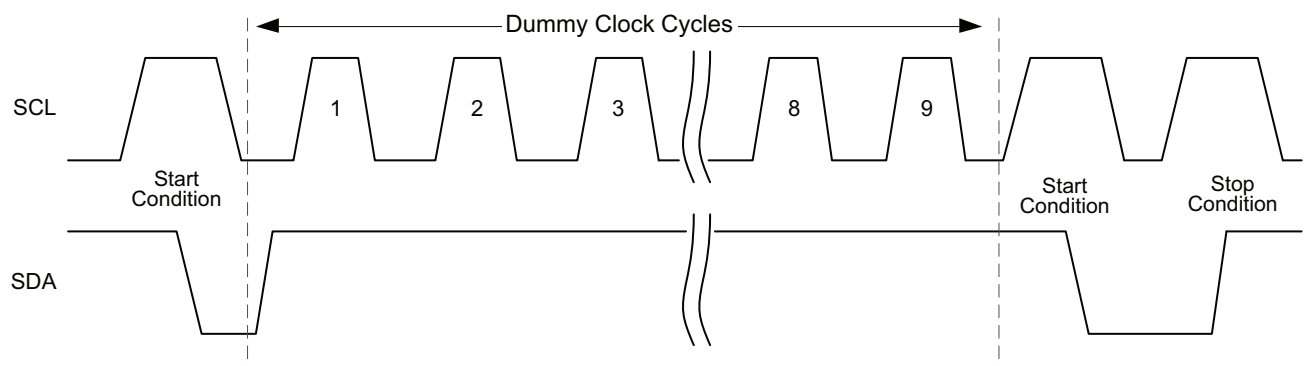

**Figure 6-5. Bus Timing**

SCL: Serial Clock, SDA: Serial Data I/O



**Figure 6-6. Write Cycle Timing**

SCL: Serial Clock, SDA: Serial Data I/O



Note: 1. The write cycle time  $t_{WR}$  is the time from a valid Stop condition of a write sequence to the end of the internal clear/write cycle.



## 7. Device Addressing

The 1-Mbit EEPROM requires an 8-bit device address word following a Start condition to enable the chip for a read or write operation (see [Figure 7-1](#) below). The device address word consists of a mandatory '1010' sequence for the first four most significant bits. This is common to all 2-wire EEPROM devices.

The 1-Mbit uses the two device address bits, A<sub>2</sub> and A<sub>1</sub>, to allow up to four devices on the same bus. These A<sub>2</sub> and A<sub>1</sub> bits must compare to the corresponding hardwired input pins, A<sub>2</sub> and A<sub>1</sub>. The A<sub>2</sub> and A<sub>1</sub> pins uses an internal proprietary circuit that biases it to a logic low condition if the pin is allowed to float.

The seventh bit (P<sub>0</sub>) of the device address is a memory page address bit. This memory page address bit is the most significant bit of the data word address that follows. The eighth bit of the device address is the read/write operation select bit. A read operation is initiated if this bit is high and a write operation is initiated if this bit is low.

Upon a compare of the device address, the EEPROM will output a zero. If a valid compare is not made, the device will return to a standby state.

**Figure 7-1. Device Address**

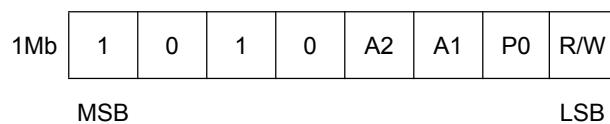

## 8. Write Operations

**Byte Write:** To select a data word in the 1-Mbit memory requires a 17-bit word address. The word address field consists of the P<sub>0</sub> bit in the device address byte, then the most significant word address followed by the least significant word address ([Figure 8-1](#)).

A write operation requires the P<sub>0</sub> bit and two 8-bit data word addresses following the device address word and acknowledgment. Upon receipt of this address, the EEPROM will again respond with a zero and then the part is to receive the first 8-bit data word. Following receipt of the 8-bit data word, the EEPROM will output a zero. The addressing device, such as a microcontroller, then must terminate the write sequence with a Stop condition. At this time the EEPROM enters an internally timed write cycle, t<sub>WR</sub>, to the nonvolatile memory. All inputs are disabled during this write cycle and the EEPROM will not respond until the write is complete ([Figure 8-1](#)).

**Figure 8-1. Byte Write**



**Page Write:** The 1-Mbit EEPROM is capable of a 256-byte Page Write.

A Page Write is initiated the same way as a Byte Write, but the microcontroller does not send a Stop condition after the first data word is clocked in. Instead, after the EEPROM acknowledges receipt of the first data word, the microcontroller can transmit up to 255 more data words. The EEPROM will respond with an acknowledge after each data word is received. The microcontroller must terminate the page write sequence with a Stop condition (Figure 8-2) and the internally timed write cycle will begin.

The data word address lower 8 bits are internally incremented following the receipt of each data word. The higher data word address bits are not incremented, retaining the memory page row location. When the internally generated word address, reaches the page boundary, the following byte is placed at the beginning of the same page. If more than 256 data words are transmitted to the EEPROM, the data word address will “roll over” and previous data will be overwritten. The address “rollover” during write is from the last byte of the current page to the first byte of the same page.

**Figure 8-2. Page Write**



**Acknowledge Polling:** Once the internally timed write cycle has started and the EEPROM inputs are disabled, Acknowledge Polling can be initiated. This involves sending a Start condition followed by the device address word. The read/write bit is representative of the operation desired. Only if the internal write cycle has completed will the EEPROM respond with a zero, allowing a new read or write sequence to be initiated.

**Data Security:** The AT24CM01 has a hardware data protection scheme that allows the user to write protect the entire memory when the WP pin is at  $V_{CC}$ .

## 9. Read Operations

Read operations are initiated the same way as write operations with the exception that the read/write select bit in the device address word is set to one. There are three read operations: Current Address Read, Random Address Read, and Sequential Read.

**Current Address Read:** The internal data word address counter maintains the last address accessed during the last read or write operation, incremented by one. This address stays valid between operations as long as the  $V_{CC}$  to the part is maintained. The address “rollover” during read is from the last byte of the last page, to the first byte of the first page of the memory.

Once the device address with the read/write select bit set to one is input and acknowledged by the EEPROM, the current address data word is serially clocked out on the SDA line. The microcontroller does not respond with a zero but does generate a following Stop condition.

**Figure 9-1. Current Address Read**

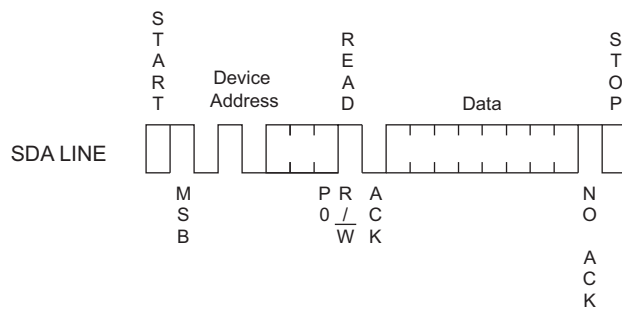

**Random Read:** A Random Read requires an initial byte write sequence to load in the data word address. This is known as a “dummy write” operation. Once the device address word and data word address are clocked in and acknowledged by the EEPROM, the microcontroller must generate another Start condition. The microcontroller now initiates a current address read by sending a device address with the read/write select bit high. The EEPROM acknowledges the device address and serially clocks out the data word on the SDA line. The microcontroller does not respond with a zero but does generate a following Stop condition.

**Figure 9-2. Random Read**

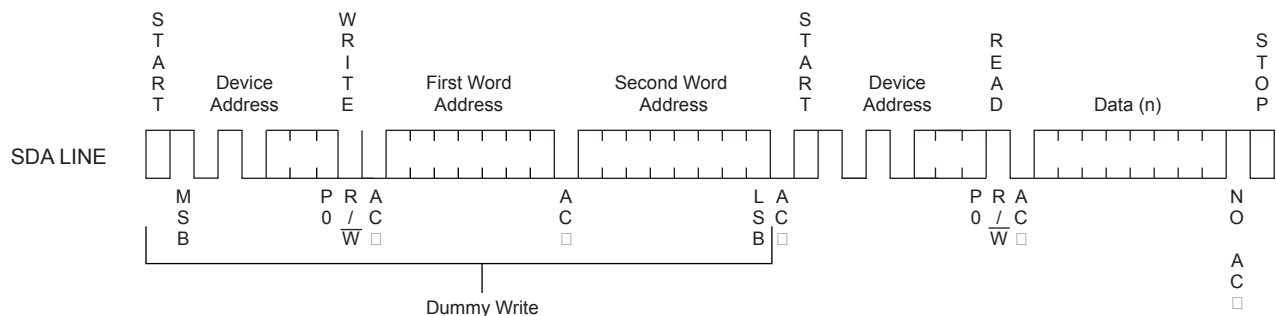

**Sequential Read:** Sequential Reads are initiated by either a Current Address Read or a Random Read. After the microcontroller receives a data word, it responds with an acknowledge. As long as the EEPROM receives an acknowledge, it will continue to increment the data word address and serially clock out sequential data words. When the memory address limit is reached, the data word address will “roll over” and the sequential read will continue. The Sequential Read operation is terminated when the microcontroller does not respond with a zero, but does generate a following Stop condition.

**Figure 9-3. Sequential Read**



## 10. Ordering Code Detail



# 11. Part Markings

## AT24CM01: Package Marking Information

8-lead SOIC	8-lead EIAJ
8-lead TSSOP	8-ball WLCSP

Note 1: ● designates pin 1  
 Note 2: Package drawings are not to scale

<b>Catalog Number Truncation</b>			
AT24CM01		Truncation Code ###: 2G	
<b>Date Codes</b>			<b>Voltages</b>
Y = Year	M = Month	WW = Work Week of Assembly	% = Minimum Voltage
4: 2014    8: 2018	A: January	02: Week 2	D: 2.5V min
5: 2015    9: 2019	B: February	04: Week 4	M: 1.7V min
6: 2016    0: 2020	...	...	
7: 2017    1: 2021	L: December	52: Week 52	
<b>Country of Assembly</b>		<b>Lot Number</b>	<b>Grade/Lead Finish Material</b>
@ = Country of Assembly		AAA...A = Atmel Wafer Lot Number	H: Industrial/NiPdAu U: Industrial/Matte Tin/SnAgCu
<b>Trace Code</b>			<b>Atmel Truncation</b>
XX = Trace Code (Atmel Lot Numbers Correspond to Code) Example: AA, AB.... YZ, ZZ			AT: Atmel ATM: Atmel ATML: Atmel

12/12/14

 Package Mark Contact: DL-CSO-Assy_eng@atmel.com	<b>TITLE</b>	<b>DRAWING NO.</b>	<b>REV.</b>
	24CM01SM, AT24CM01 Package Marking Information	24CM01SM	F

## 12. Ordering Information

Atmel Ordering Code	Lead Finish	Package	Voltage	Delivery Information		Operation Range
				Form	Quantity	
AT24CM01-SSHM-B	NiPdAu (Lead-free/Halogen-free)	8S1	1.7V to 5.5V	Bulk (Tubes)	100 per Tube	Industrial Temperature (-40°C to 85°C)
AT24CM01-SSHM-T				Tape and Reel	4,000 per Reel	
AT24CM01-SSHD-B			2.5V to 5.5V	Bulk (Tubes)	100 per Tube	
AT24CM01-SSHD-T				Tape and Reel	4,000 per Reel	
AT24CM01-SHM-B		8S2	1.7V to 5.5V	Bulk (Tubes)	95 per Tube	
AT24CM01-SHM-T				Tape and Reel	2,000 per Reel	
AT24CM01-SHD-B			2.5V to 5.5V	Bulk (Tubes)	95 per Tube	
AT24CM01-SHD-T				Tape and Reel	2,000 per Reel	
AT24CM01-XHM-B		8X	1.7V to 5.5V	Bulk (Tubes)	100 per Tube	
AT24CM01-XHM-T				Tape and Reel	5,000 per Reel	
AT24CM01-XHD-B			2.5V to 5.5V	Bulk (Tubes)	100 per Tube	
AT24CM01-XHD-T				Tape and Reel	5,000 per Reel	
AT24CM01-UUM-T <sup>(1)</sup>	SnAgCu (Lead-free/Halogen-free)	8U-6	1.7V to 5.5V	Tape and Reel	5,000 per Reel	
AT24CM01-WWU11M <sup>(2)</sup>	N/A	Wafer Sale		Note 2		

- Notes: 1. WLCSP Package — **CAUTION:** Exposure to ultraviolet (UV) light can degrade the data stored in the EEPROM cells. Therefore, customers who use a WLCSP product must ensure that exposure to ultraviolet light does **not** occur.
2. For wafer sales, please contact Atmel Sales.

Package Type	
8S1	8-lead, 0.150" wide, Plastic Gull Wing Small Outline (JEDEC SOIC)
8S2	8-lead, 0.208" wide, Plastic Gull Wing Small Outline (EIAJ SOIC)
8X	8-lead, 4.4mm body, Plastic Thin Shrink Small Outline (TSSOP)
8U-6	8-ball, 3x5 Grid Array, Wafer Level Chip Scale (WLCSP)

## 13. Packaging Information

### 13.1 8S1 — 8-lead JEDEC SOIC





## 13.2 8S2 — 8-lead EIAJ SOIC



### 13.3 8X — 8-lead TSSOP



### 13.4 8U-6 — 8-ball WLCSP

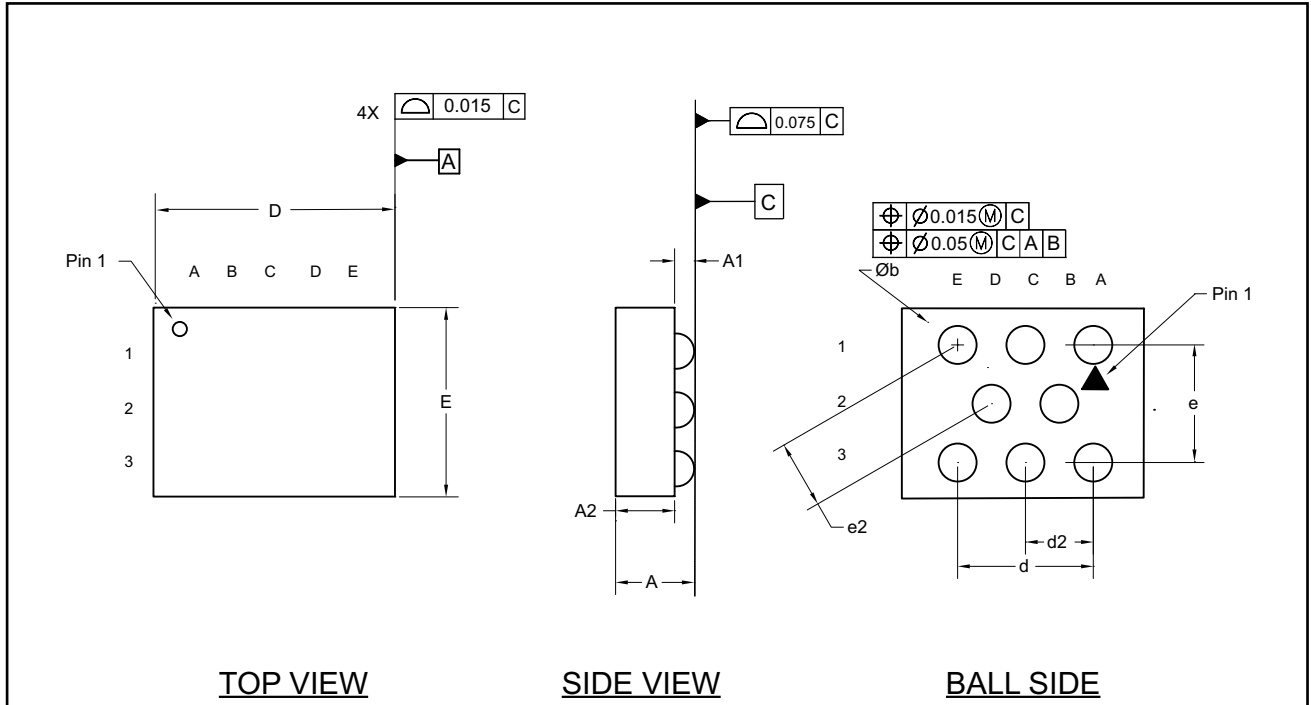

\* Dimensions are NOT to scale.

Pin Assignment Matrix

	A	B	C	D	E
1	V <sub>CC</sub>		WP		NC
2		SCL		A1	
3	SDA		A2		GND

COMMON DIMENSIONS  
(Unit of Measure = mm)

SYMBOL	MIN	TYP	MAX	NOTE
A	0.460	0.499	0.538	
A1	0.164	-	0.224	
A2	0.280	0.305	0.330	
E	Contact Atmel for details			
e		0.866		
e2		0.500		
d		1.000		
d2		0.500		
D	Contact Atmel for details			
b	0.239	0.269	0.299	

4/25/13

<p>Package Drawing Contact: packagedrawings@atmel.com</p>	<b>TITLE</b> 8U-6, 8-ball (3x5 Array) Wafer Level Chip Scale Package (WLCSP)	<b>GPC</b>	<b>DRAWING NO.</b>	<b>REV.</b>
		GHZ	8U-6	B

## 14. Revision History

Doc. No.	Date	Comments
8821F	01/2015	Update the ordering information section, part markings, and the 8X and 8S2 package outline drawings.
8821E	03/2013	Update document status from preliminary to complete. Correct WLCSP pinout. Update footers and disclaimer page.
8812D	01/2013	Correct TSSOP pin label 7 to WP.
8812C	12/2012	Add WLCSP package. Update part markings. Update pinout diagram. Update part markings. Correct Byte Write figure from second typo error to first word address. Update Sequential Read figure.
8812B	07/2012	Correct ordering code: - AT24CM01-WWU-11, Die Sale to AT24CM01-WWU11M, Wafer Sale. Update Atmel logos and disclaimer page.
8812A	05/2012	Initial document release.

