

UNCONTROLLED DOCUMENT

SC:0.25

PART NUMBER

SSH-LX3050

REV.

C

UNDER REVISION

| REV. | E.C.N. NUMBER AND REVISION COMMENTS | DATE     |
|------|-------------------------------------|----------|
| A    | E.C.N. #10BRDR. & REDRAWN.          | 09.15.99 |
| B    | E.C.N. #11476.                      | 02.18.08 |
| C    | E.C.N. #11519.                      | 08.07.08 |

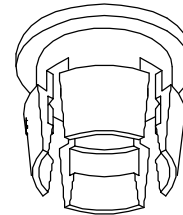
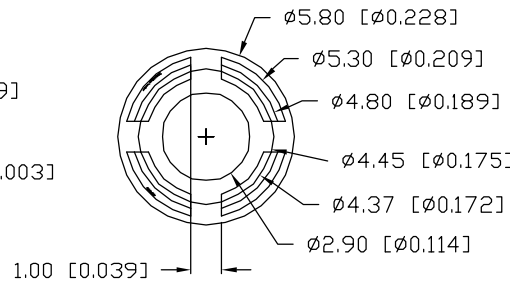
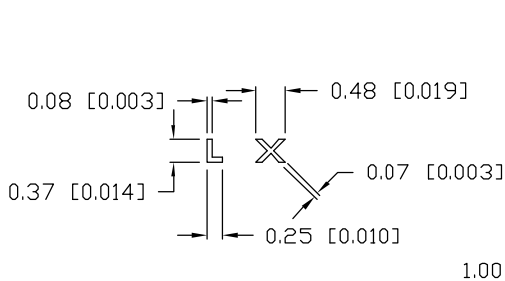
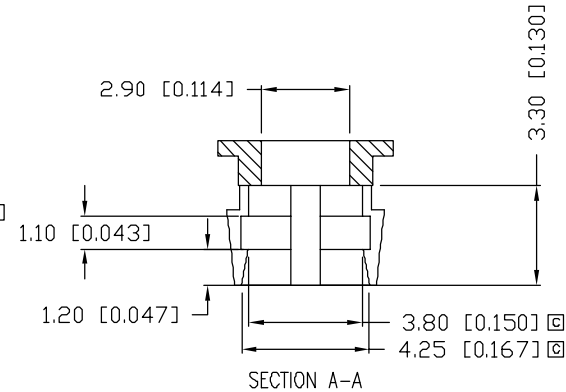
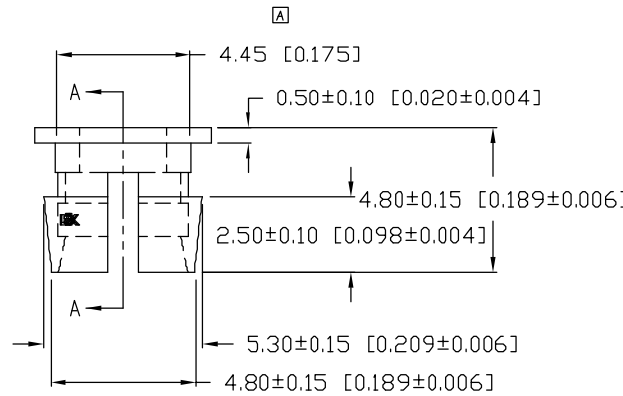
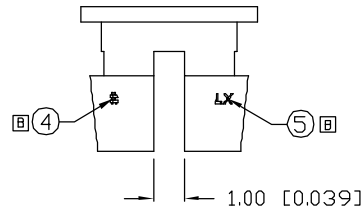
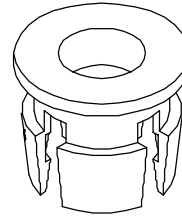
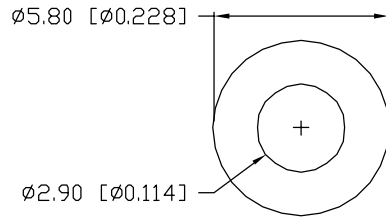

NOTES:

1. MATERIAL: POLYPROPYLENE (PP), BLACK.
2. PANEL HOLE CUT OUT:  $\phi 4.45\text{mm}$  [0.175"].
3. PANEL THICKNESS: 1.65mm [0.065"].
4. CAVITY NUMBER.
5. LX MARKING.



UNCONTROLLED DOCUMENT

\*UNLESS OTHERWISE SPECIFIED TOLERANCES PER DECIMAL PRECISION ARE: X=±1 (±0.039), X.X=±0.5 (±0.020), X.XX=±0.25 (±0.010), X.XXX=±0.127 (±0.005). LEAD SIZE=±0.05 (±0.002), LEAD LENGTH=±0.75 (±0.030). MIN.=+DECIMAL PRECISION -0.00 MAX.=+0.00 -DECIMAL PRECISION

|           |                           |
|-----------|---------------------------|
| REV.<br>C | PART NUMBER<br>SSH-LX3050 |
|-----------|---------------------------|

**CONFIDENTIAL INFORMATION**  
THE INFORMATION CONTAINED IN THIS DOCUMENT IS THE PROPERTY OF LUMEX INC. EXCEPT AS SPECIFICALLY AUTHORIZED IN WRITING BY LUMEX INC., THE HOLDER OF THIS DOCUMENT SHALL KEEP ALL INFORMATION CONTAINED HEREIN CONFIDENTIAL AND SHALL PROTECT SAME IN WHOLE OR IN PART FROM DISCLOSURE AND DISSEMINATION TO ALL THIRD PARTIES.



290 E. HELEN ROAD  
PALATINE, IL 60067-6976  
PHONE: +1.847.359.2790  
US WEB: www.lumex.com  
TW WEB: www.lumex.com.tw

3mm LED PANEL CLIP FOR LX3050 TYPES.

**RELIABILITY NOTE**  
OUR MANY YEARS OF EXPERIENCE DATA ACCUMULATION INDICATE THAT SOLDER HEAT IS A MAJOR CAUSE OF EARLY AND FUTURE FAILURE. PLEASE PAY ATTENTION TO YOUR SOLDERING PROCESS.

|                 |             |              |                                              |
|-----------------|-------------|--------------|----------------------------------------------|
| DRAWN BY:<br>DU | CHECKED BY: | APPROVED BY: | DATE: 03.01.99<br>PAGE: 1 OF 1<br>SCALE: N/A |
|-----------------|-------------|--------------|----------------------------------------------|