

Features

- Fast read access time – 45ns
- Low-power CMOS operation
 - 100µA max standby
 - 20mA max active at 5MHz
- JEDEC standard packages
 - 28-lead PDIP
 - 32-lead PLCC
- 5V ± 10% supply
- High reliability CMOS technology
 - 2,000V ESD protection
 - 200mA latchup immunity
- Rapid programming algorithm – 100µs/byte (typical)
- CMOS- and TTL-compatible inputs and outputs
- Integrated product identification code
- Industrial and automotive temperature ranges
- Green (Pb/halide-free) packaging option

1. Description

The Atmel® AT27C256R is a low-power, high-performance, 262,144-bit, one-time programmable, read-only memory (OTP EPROM) organized as 32K by 8 bits. It requires only one 5V power supply in normal read mode operation. Any byte can be accessed in less than 45ns, eliminating the need for speed reducing WAIT states on high-performance microprocessor systems.

The Atmel scaled CMOS technology provides low active power consumption and fast programming. Power consumption is typically only 8mA in active mode and less than 10µA in standby mode.

The AT27C256R is available in a choice of industry-standard, JEDEC-approved, one-time programmable (OTP) PDIP and PLCC packages. All devices feature two-line control (\overline{CE} , \overline{OE}) to give designers the flexibility to prevent bus contention.

With 32K byte storage capability, the AT27C256R allows firmware to be stored reliably and to be accessed by the system without the delays of mass storage media.

The AT27C256R has additional features to ensure high quality and efficient production use. The rapid programming algorithm reduces the time required to program the part and guarantees reliable programming. Programming time is typically only 100µs/byte. The integrated product identification code electronically identifies the device and manufacturer. This feature is used by industry-standard programming equipment to select the proper programming algorithms and voltages.



256K (32K x 8)
One-time
Programmable,
Read-only Memory

Atmel AT27C256R



2. Pin configurations

| Pin name | Function |
|-----------------|---------------|
| A0 - A14 | Addresses |
| O0 - O7 | Outputs |
| \overline{CE} | Chip enable |
| \overline{OE} | Output enable |
| NC | No connect |



Note: PLCC package pins 1 and 17 are "don't connect"

3. System considerations

Switching between active and standby conditions via the chip enable pin may produce transient voltage excursions. Unless accommodated by the system design, these transients may exceed datasheet limits, resulting in device non-conformance. At a minimum, a 0.1 μ F, high-frequency, low inherent inductance, ceramic capacitor should be utilized for each device. This capacitor should be connected between the V_{CC} and ground terminals of the device, as close to the device as possible. Additionally, to stabilize the supply voltage level on printed circuit boards with large EPROM arrays, a 4.7 μ F bulk electrolytic capacitor should be utilized, again connected between the V_{CC} and ground terminals. This capacitor should be positioned as close as possible to the point where the power supply is connected to the array.

Figure 3-1. Block diagram



4. Absolute maximum ratings*

| | |
|---|--------------------------------|
| Temperature under bias | -55°C to +125°C |
| Storage temperature | -65°C to +150°C |
| Voltage on any pin with respect to ground | -2.0V to +7.0V ⁽¹⁾ |
| Voltage on A9 with respect to ground | -2.0V to +14.0V ⁽¹⁾ |
| V _{pp} supply voltage with respect to ground | -2.0V to +14.0V ⁽¹⁾ |

*NOTICE: Stresses beyond those listed under “Absolute maximum ratings” may cause permanent damage to the device. This is a stress rating only, and functional operation of the device at these or any other conditions beyond those indicated in the operational sections of this specification is not implied. Exposure to absolute maximum rating conditions for extended periods may affect device reliability.

Note: 1. Minimum voltage is -0.6V DC, which may undershoot to -2.0V for pulses of less than 20ns. Maximum output pin voltage is V_{CC} + 0.75V DC, which may overshoot to +7.0V for pulses of less than 20ns.

5. DC and AC characteristics

Table 5-1. Operating Modes

| Mode/Pin | \overline{CE} | \overline{OE} | Ai | V _{PP} | Outputs |
|---------------------------------------|------------------|------------------|---|-----------------|---------------------|
| Read | V _{IL} | V _{IL} | Ai | V _{CC} | D _{OUT} |
| Output disable | V _{IL} | V _{IH} | X ⁽¹⁾ | V _{CC} | High Z |
| Standby | V _{IH} | X ⁽¹⁾ | X ⁽¹⁾ | V _{CC} | High Z |
| Rapid program ⁽²⁾ | V _{IL} | V _{IH} | Ai | V _{PP} | D _{IN} |
| PGM verify ⁽²⁾ | X ⁽¹⁾ | V _{IL} | Ai | V _{PP} | D _{OUT} |
| Optional PGM verify ⁽²⁾ | V _{IL} | V _{IL} | Ai | V _{CC} | D _{OUT} |
| PGM inhibit ⁽²⁾ | V _{IH} | V _{IH} | X ⁽¹⁾ | V _{PP} | High Z |
| Product identification ⁽⁴⁾ | V _{IL} | V _{IL} | A9 = V _H ⁽³⁾ A0 = V _{IH} or V _{IL} A1 - A14 = V _{IL} | V _{CC} | Identification code |

Notes: 1. X can be V_{IL} or V_{IH}.
 2. Refer to programming characteristics.
 3. V_H = 12.0 ± 0.5V.
 4. Two identifier bytes may be selected. All Ai inputs are held low (V_{IL}), except A9, which is set to V_{IH}, and A0, which is toggled low (V_{IL}) to select the manufacturer’s identification byte and high (V_{IH}) to select the device code byte.

Table 5-2. DC and AC operating conditions for read operation

| | | Atmel AT27C256R | |
|------------------------|-------|-----------------|---------------|
| | | -45 | -70 |
| Operating temp. (case) | Ind. | -40°C - 85°C | -40°C - 85°C |
| | Auto. | | -40°C - 125°C |
| V _{CC} supply | | 5V ± 10% | 5V ± 10% |

Table 5-3. DC and operating characteristics for read operation

| Symbol | Parameter | Condition | Min | Max | Units | |
|-----------------|-------------------------------------|---|-------|----------------|----------|---------|
| I_{LI} | Input load current | $V_{IN} = 0V$ to V_{CC} | Ind. | | ± 1 | μA |
| | | | Auto. | | ± 5 | μA |
| I_{LO} | Output leakage current | $V_{OUT} = 0V$ to V_{CC} | Ind. | | ± 5 | μA |
| | | | Auto. | | ± 10 | μA |
| $I_{PP1}^{(2)}$ | $V_{PP}^{(1)}$ read/standby current | $V_{PP} = V_{CC}$ | | 10 | μA | |
| I_{SB} | $V_{CC}^{(1)}$ standby current | I_{SB1} (CMOS), $\overline{CE} = V_{CC} \pm 0.3V$ | | 100 | μA | |
| | | I_{SB2} (TTL), $\overline{CE} = 2.0$ to $V_{CC} + 0.5V$ | | 1 | mA | |
| I_{CC} | V_{CC} active current | $f = 5MHz$, $I_{OUT} = 0mA$, $\overline{E} = V_{IL}$ | | 20 | mA | |
| V_{IL} | Input low voltage | | -0.6 | 0.8 | V | |
| V_{IH} | Input high voltage | | 2.0 | $V_{CC} + 0.5$ | V | |
| V_{OL} | Output low voltage | $I_{OL} = 2.1mA$ | | 0.4 | V | |
| V_{OH} | Output high voltage | $I_{OH} = -400\mu A$ | 2.4 | | V | |

- Notes:
- V_{CC} must be applied simultaneously with or before V_{PP} , and removed simultaneously with or after V_{PP} .
 - V_{PP} may be connected directly to V_{CC} , except during programming. The supply current would then be the sum of I_{CC} and I_{PP} .

Table 5-4. AC characteristics for read operation

| Symbol | Parameter | Condition | Atmel AT27C256R | | | | Units |
|-----------------|---|--|-----------------|-----|-----|-----|-------|
| | | | -45 | | -70 | | |
| | | | Min | Max | Min | Max | |
| $t_{ACC}^{(1)}$ | Address to output delay | $\overline{CE} = \overline{OE} = V_{IL}$ | | 45 | | 70 | ns |
| $t_{CE}^{(1)}$ | \overline{CE} to output delay | $\overline{OE} = V_{IL}$ | | 45 | | 70 | ns |
| $t_{OE}^{(1)}$ | \overline{OE} to output delay | $\overline{CE} = V_{IL}$ | | 20 | | 30 | ns |
| $t_{DF}^{(1)}$ | \overline{OE} or \overline{CE} high to output float, whichever occurred first | | | 20 | | 25 | ns |
| t_{OH} | Output hold from address, \overline{CE} or \overline{OE} , whichever occurred first | | 7 | | 7 | | ns |

- Note:
- See AC waveforms for read operation.

Figure 5-1. AC waveforms for read operation⁽¹⁾

- Notes:
1. Timing measurement reference level is 1.5V for -45 devices. Input AC drive levels are $V_{IL} = 0.0V$ and $V_{IH} = 3.0V$. Timing measurement reference levels for all other speed grades are $V_{OL} = 0.8V$ and $V_{OH} = 2.0V$. Input AC drive levels are $V_{IL} = 0.45V$ and $V_{IH} = 2.4V$.
 2. \overline{OE} may be delayed up to $t_{CE} - t_{OE}$ after the falling edge of \overline{CE} without impact on t_{CE} .
 3. \overline{OE} may be delayed up to $t_{ACC} - t_{OE}$ after the address is valid without impact on t_{ACC} .
 4. This parameter is only sampled, and is not 100% tested.
 5. Output float is defined as the point when data is no longer driven.

Figure 5-2. Input test waveforms and measurement levels

For -45 devices only:



For -70 devices:



Figure 5-3. Output test load

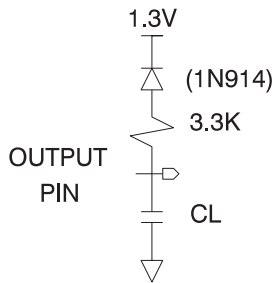

Note: 1. $C_L = 100\text{pF}$ including jig capacitance, except for the -45 devices, where $C_L = 30\text{pF}$.

Table 5-5. Pin capacitance

$f = 1\text{MHz}$, $T = 25^\circ\text{C}$ ⁽¹⁾

| Symbol | Typ | Max | Units | Conditions |
|-----------|-----|-----|-------|-----------------------|
| C_{IN} | 4 | 6 | pF | $V_{IN} = 0\text{V}$ |
| C_{OUT} | 8 | 12 | pF | $V_{OUT} = 0\text{V}$ |

Note: 1. Typical values for nominal supply voltage. This parameter is only sampled, and is not 100% tested.

Figure 5-4. Programming Waveforms⁽¹⁾

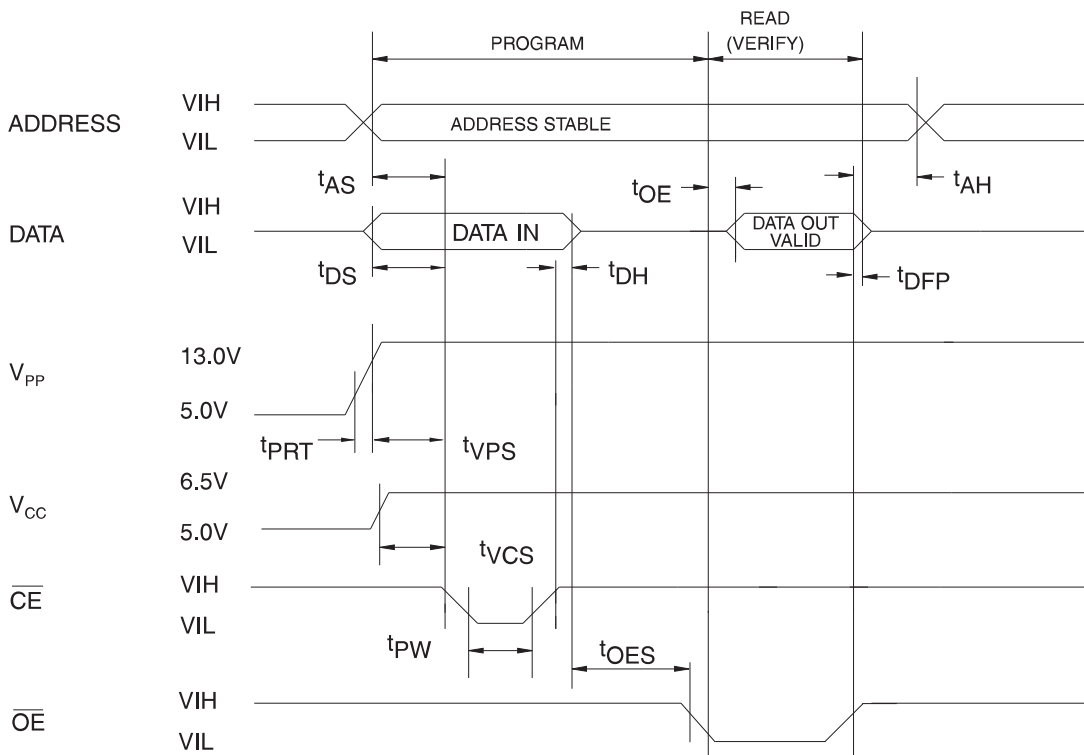

- Notes:
1. The input timing reference is 0.8V for V_{IL} and 2.0V for V_{IH} .
 2. t_{OE} and t_{DFP} are characteristics of the device, but must be accommodated by the programmer.
 3. When programming the Atmel AT27C256R, a 0.1 μF capacitor is required across V_{PP} and ground to suppress spurious voltage transients.

Table 5-6. DC programming characteristics

 $T_A = 25 \pm 5^\circ\text{C}$, $V_{CC} = 6.5 \pm 0.25\text{V}$, $V_{PP} = 13.0 \pm 0.25\text{V}$

| Symbol | Parameter | Test Conditions | Limits | | Units |
|-----------|--|----------------------------|--------|--------------|---------------|
| | | | Min | Max | |
| I_{LI} | Input load current | $V_{IN} = V_{IL}, V_{IH}$ | | ± 10 | μA |
| V_{IL} | Input low level | | -0.6 | 0.8 | V |
| V_{IH} | Input high level | | 2.0 | $V_{CC} + 1$ | V |
| V_{OL} | Output low volt | $I_{OL} = 2.1\text{mA}$ | | 0.4 | V |
| V_{OH} | Output high volt | $I_{OH} = -400\mu\text{A}$ | 2.4 | | V |
| I_{CC2} | V_{CC} supply current (program and verify) | | | 25 | mA |
| I_{PP2} | V_{PP} current | $\overline{CE} = V_{IL}$ | | 25 | mA |
| V_{ID} | A9 product identification voltage | | 11.5 | 12.5 | V |

Table 5-7. AC programming characteristics

 $T_A = 25 \pm 5^\circ\text{C}$, $V_{CC} = 6.5 \pm 0.25\text{V}$, $V_{PP} = 13.0 \pm 0.25\text{V}$

| Symbol | Parameter | Test conditions ⁽¹⁾ | Limits | | Units |
|-----------|---|--|--------|-----|---------------|
| | | | Min | Max | |
| t_{AS} | Address setup time | Input rise and fall times (10% to 90%) 20ns | 2 | | μs |
| t_{OES} | \overline{OE} setup time | | 2 | | μs |
| t_{DS} | Data setup time | | 2 | | μs |
| t_{AH} | Address hold time | Input pulse levels 0.45V to 2.4V | 0 | | μs |
| t_{DH} | Data hold time | | 2 | | μs |
| t_{DFP} | \overline{OE} high to output float delay ⁽²⁾ | | 0 | 130 | ns |
| t_{VPS} | V_{PP} setup time | Input timing reference level 0.8V to 2.0V | 2 | | μs |
| t_{VCS} | V_{CC} setup time | | 2 | | μs |
| t_{PW} | \overline{CE} program pulse width ⁽³⁾ | Output timing reference level 0.8V to 2.0V | 95 | 105 | μs |
| t_{OE} | Data valid from \overline{OE} ⁽²⁾ | | | 150 | ns |
| t_{PRT} | V_{PP} pulse rise time during programming | | 50 | | ns |

- Notes:
- V_{CC} must be applied simultaneously with or before V_{PP} and removed simultaneously with or after V_{PP} .
 - This parameter is only sampled, and is not 100% tested. Output float is defined as the point where data is no longer driven. See timing diagram.
 - Program pulse width tolerance is $100\mu\text{s} \pm 5\%$.

Table 5-8. The Atmel AT27C256R integrated product identification code

| Codes | Pins | | | | | | | | | Hex data |
|--------------|------|----|----|----|----|----|----|----|----|----------|
| | A0 | O7 | O6 | O5 | O4 | O3 | O2 | O1 | O0 | |
| Manufacturer | 0 | 0 | 0 | 0 | 1 | 1 | 1 | 1 | 0 | 1E |
| Device type | 1 | 1 | 0 | 0 | 0 | 1 | 1 | 0 | 0 | 8C |

6. Rapid programming algorithm

A $100\mu\text{s}$ $\overline{\text{CE}}$ pulse width is used to program. The address is set to the first location. V_{CC} is raised to 6.5V and V_{PP} is raised to 13.0V. Each address is first programmed with one $100\mu\text{s}$ $\overline{\text{CE}}$ pulse without verification. Then a verification/reprogramming loop is executed for each address. In the event a byte fails to pass verification, up to 10 successive $100\mu\text{s}$ pulses are applied with a verification after each pulse. If the byte fails to verify after 10 pulses have been applied, the part is considered failed. After the byte verifies properly, the next address is selected until all have been checked. V_{PP} is then lowered to 5.0V and V_{CC} to 5.0V. All bytes are read again and compared with the original data to determine if the device passes or fails.

Figure 6-1. Rapid programming algorithm



7. Ordering information

Green package (Pb/halide-free)

| t_{ACC} (ns) | I_{CC} (mA) | | Atmel ordering code | Package | Lead finish | Operation range |
|-------------------|---------------|---------|---------------------|---------|-------------|-------------------------------|
| | Active | Standby | | | | |
| 45 | 20 | 0.1 | AT27C256R-45JU | 32J | Matte tin | Industrial (-40°C to 85°C) |
| | | | AT27C256R-45PU | 28P6 | Matte tin | |
| 70 | 20 | 0.1 | AT27C256R-70JU | 32J | Matte tin | Industrial (-40°C to 85°C) |
| | | | AT27C256R-70PU | 28P6 | Matte tin | |

| Package type | |
|--------------|---|
| 32J | 32-lead, plastic, J-leaded chip carrier (PLCC) |
| 28P6 | 28-lead, 0.600" wide, plastic, dual inline package (PDIP) |

8. Packaging information

32J – PLCC



28P6 – PDIP



COMMON DIMENSIONS
(Unit of Measure = mm)

| SYMBOL | MIN | NOM | MAX | NOTE |
|--------|-----------|-----|--------|--------|
| A | - | - | 4.826 | |
| A1 | 0.381 | - | - | |
| D | 36.703 | - | 37.338 | Note 2 |
| E | 15.240 | - | 15.875 | |
| E1 | 13.462 | - | 13.970 | Note 2 |
| B | 0.356 | - | 0.559 | |
| B1 | 1.041 | - | 1.651 | |
| L | 3.048 | - | 3.556 | |
| C | 0.203 | - | 0.381 | |
| eB | 15.494 | - | 17.526 | |
| e | 2.540 TYP | | | |

- Notes:
1. This package conforms to JEDEC reference MS-011, variation AB
 2. Dimensions D and E1 do not include mold flash or protrusion
mold flash or protrusion shall not exceed 0.25mm (0.010")

09/28/01



Package drawing contact:
packagedrawings@atmel.com

TITLE

28P6, 28-lead (0.600"/15.24mm wide) plastic dual inline package (PDIP)

DRAWING NO.

28P6

REV.

B





9. Revision history

| Doc. rev. | Date | Comments |
|-----------|---------|--|
| 0014O | 10/2011 | Correct pinouts |
| 0014N | 04/2011 | Remove TSOP and SOIC packages Add lead finish to ordering information |
| 0014M | 12/2007 | |



**Atmel Corporation**

2325 Orchard Parkway
San Jose, CA 95131
USA

Tel: (+1) (408) 441-0311

Fax: (+1) (408) 487-2600

www.atmel.com

Atmel Asia Limited

Unit 01-5 & 16, 19F
BEA Tower, Millennium City 5
418 Kwun Tong Road

Kwun Tong, Kowloon

HONG KONG

Tel: (+852) 2245-6100

Fax: (+852) 2722-1369

Atmel Munich GmbH

Business Campus
Parkring 4
D-85748 Garching b. Munich
GERMANY

Tel: (+49) 89-31970-0

Fax: (+49) 89-3194621

Atmel Japan

9F, Tonetsu Shinkawa Bldg.
1-24-8 Shinkawa
Chuo-ku, Tokyo 104-0033
JAPAN

Tel: (+81) (3) 3523-3551

Fax: (+81) (3) 3523-7581

© 2011 Atmel Corporation. All rights reserved. / Rev.: 00140-EPROM-10/11

Atmel®, logo and combinations thereof, and others are registered trademarks or trademarks of Atmel Corporation or its subsidiaries. Other terms and product names may be trademarks of others.

Disclaimer: The information in this document is provided in connection with Atmel products. No license, express or implied, by estoppel or otherwise, to any intellectual property right is granted by this document or in connection with the sale of Atmel products. EXCEPT AS SET FORTH IN THE ATMEL TERMS AND CONDITIONS OF SALES LOCATED ON THE ATMEL WEBSITE, ATMEL ASSUMES NO LIABILITY WHATSOEVER AND DISCLAIMS ANY EXPRESS, IMPLIED OR STATUTORY WARRANTY RELATING TO ITS PRODUCTS INCLUDING, BUT NOT LIMITED TO, THE IMPLIED WARRANTY OF MERCHANTABILITY, FITNESS FOR A PARTICULAR PURPOSE, OR NON-INFRINGEMENT. IN NO EVENT SHALL ATMEL BE LIABLE FOR ANY DIRECT, INDIRECT, CONSEQUENTIAL, PUNITIVE, SPECIAL OR INCIDENTAL DAMAGES (INCLUDING, WITHOUT LIMITATION, DAMAGES FOR LOSS AND PROFITS, BUSINESS INTERRUPTION, OR LOSS OF INFORMATION) ARISING OUT OF THE USE OR INABILITY TO USE THIS DOCUMENT, EVEN IF ATMEL HAS BEEN ADVISED OF THE POSSIBILITY OF SUCH DAMAGES. Atmel makes no representations or warranties with respect to the accuracy or completeness of the contents of this document and reserves the right to make changes to specifications and products descriptions at any time without notice. Atmel does not make any commitment to update the information contained herein. Unless specifically provided otherwise, Atmel products are not suitable for, and shall not be used in, automotive applications. Atmel products are not intended, authorized, or warranted for use as components in applications intended to support or sustain life.