

# Angle Position Sensors

## AS500106

Magnet carrier for use with Angle Position Sensors



### Features

- PPS housing
- Samarium Cobalt 28 magnet
- RoHS compliant

### Environmental Specifications

Vibration	15g sinusoidal, 9.26g RMS axial; 40 Hz – 2 kHz all 3 axes
Operation Temperature	-40 °C to 125 °C (-40 °F to 257 °F)
Storage Temperature	-40 °C to 150 °C (-40 °F to 302 °F)
Salt Spray	SAEJ1455, Section 4.3.3
Immersion	Tested per SAE J 1455, Section 4.4.1: Engine oil and additives, Transmission oils, Water, Power steering fluid, Brake fluids, Washer solvent, Gasoline, Diesel fuel, Alcohol, Antifreeze water mixture, Battery acid, Salt water, Kerosene, Ammonia

### Mechanical Specifications

Recommended Fastener	M4 Cap Screw
Recommended Torque	3 Nm (26.5 in lbs)

### Products

Part Number	Description	Sensing Range
AS500106	Magnet only	N/A
CU103601	Kit with AN820001 sensor	180°
CU103602	Kit with AN820002 sensor	360°
CU103603	Kit with AN820003 sensor	45°

### Dimensions mm (inches)

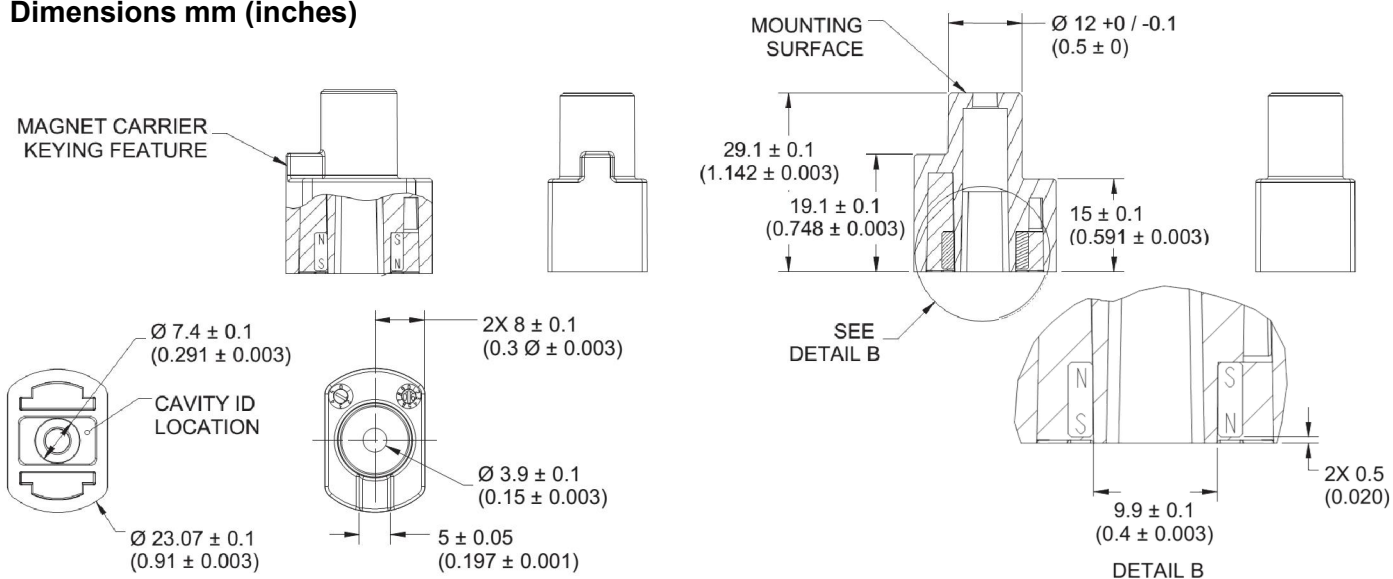

www.cherryswitches.com

