

REV.	DATE	ECR NO.	DESCRIPTION
NC	07/13/99	XXXXXX	INITIAL RELEASE
A	05/01/04	XXXXXX	UPDATE DRAWING FORMAT
B	08/09/13	2511	MODIFY LOCK WASHER O.D., ADD ELECTRICAL/MECHANICAL NOTES, UPDATE FORMAT

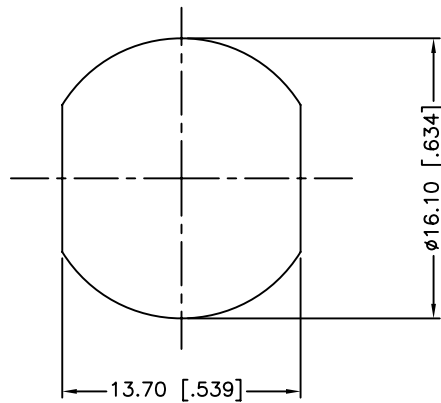

RECOMMENDED MOUNTING HOLE

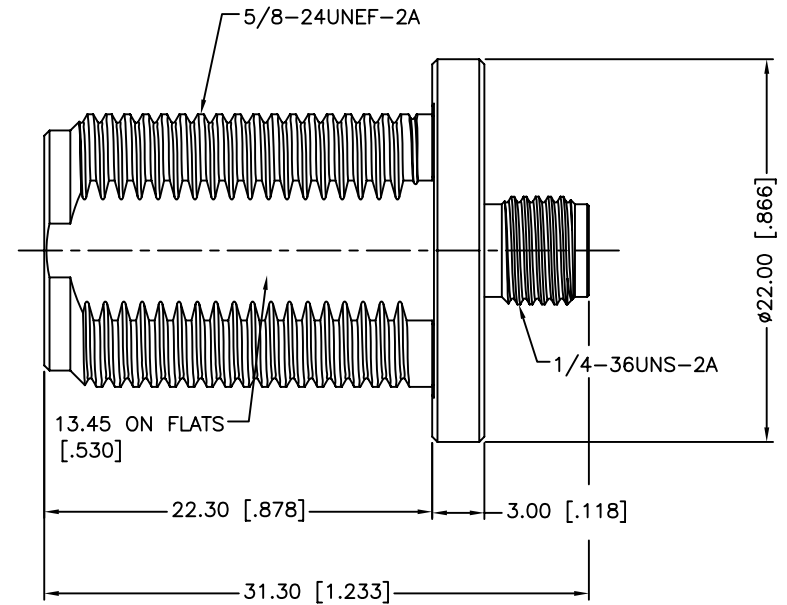
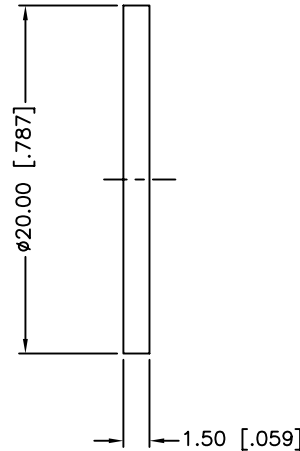
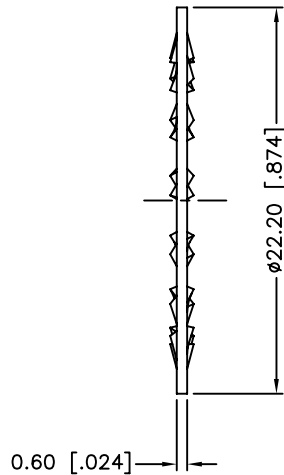
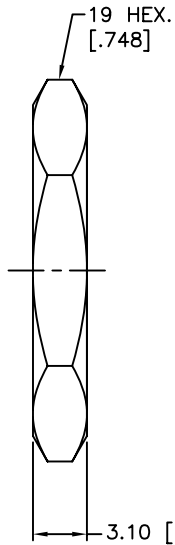

1. IMPEDANCE: 50 OHM
2. FREQUENCY RANGE: DC-11 GHZ
3. DIELECTRIC WITHSTANDING VOLTAGE: 1000 VRMS, MIN.
4. DURABILITY: 500 CYCLES MIN.
5. TEMPERATURE RANGE: -65°C TO +165°C
6. MAX. PANEL THICKNESS= 6.8mm

QTY	DESCRIPTION	MATERIAL	FINISH
1	HEX NUT	BRASS	NICKEL
1	LOCK WASHER	BRASS	NICKEL
1	GASKET	SILICONE RUBBER	RED
1	BODY	BRASS	NICKEL
1	CONTACT PIN	BER. COPPER	GOLD
1	INSULATOR	PTFE	NATURAL
1	HOUSING	BRASS	NICKEL

UNLESS OTHERWISE SPECIFIED DIMENSIONS ARE IN MILLIMETERS. DIMENSIONS IN [] ARE IN INCHES AND FOR CUSTOMER REFERENCE ONLY.
UNLESS OTHERWISE SPECIFIED
TOLERANCES FOR MILLIMETERS ARE:
<0.5 ± 0.05mm
0.5 - 6mm ± 0.10mm
6 - 30mm ± 0.20mm
30 - 120mm ± 0.30mm
ANGLES ± 1°
UNLESS OTHERWISE SPECIFIED
TOLERANCES FOR INCHES ARE:
<.020 ± 0.002"
.020 - .236 ± 0.004"
.236 - 1.180 ± 0.007"
1.180 - 4.724 ± 0.012"
ANGLES ± 1°
DO NOT SCALE DRAWING

APPROVALS	DATE
DRAWN M.ZHANG	08/09/13
CHECKED	
ISSUED	
SHEET 1 OF 1	
CAD FILE	C:/CONNEX/242125.DWG

Amphenol Connex

PART DESCRIPTION
**N FEMALE TO SMA FEMALE
BULKHEAD ADAPTOR**

PART NO.
242125

DWG. NO. 242125.DWG	REV. A	SIZE A	SCALE NA
---------------------	--------	--------	----------