

Specification For Approval

Customer

Description Open Type Air Ultrasonic Ceramic Transducers

Part Number 400PT10P

Issued Date May 25 2015

Quantity

Version

Customer Ref. No.

Customer Approval Signature/Chop

Approved By	Checked By	Prepared By

1 Scope

The Pulse/Tone Burst transducer is designed for echo ranging systems requiring a shorter ringing characteristic when comparing to our standard type transducers.

2 Part Number

400PT10P Open Type Air Ultrasonic Ceramic Transducer

3 Dimension

As per Figure 1

4 Specification

(rated at temperature $25\pm 3^{\circ}\text{C}$, 45 to 60% RH, unless otherwise noted)

	Items	Specification	Remarks
4-1	Center Frequency	40.0 \pm 1.0KHz	
4-2	Ringing (max.)	60mV	At 1.7ms, detail see attached Figure 2
4-3	Sound Pressure Level	110dB (min)	At resonant frequency; 0dB re 0.0002 μ bar per 10Vrms at 30cm 10Vrms Sine Wave input Detail see attached Figure 3
4-4	Sensitivity	-69dB (min)	At resonant frequency; 0dB re 1Volt/ μ bar Detail see attached Figure 4
4-5	Bandwidth	1.5KHz (min)	-6dB
4-6	Capacitance	1800 \pm 20%pF	Measured at 1KHz
4-7	Total Beam Angle	55 $^{\circ}$ \pm 10 $^{\circ}$	-6dB
4-8	Max. Driving Voltage	100Vp-p	20 bursts maximum, 25ms repetition rate
4-9	Operation Temperature	-30 $^{\circ}$ to +70 $^{\circ}$ C	
4-10	Storage Temperature	-40 $^{\circ}$ to +80 $^{\circ}$ C	

5 Environmental Characteristics

- 5-1** Overall echo sensitivity shall not change by more than $\pm 3\text{dB}$ in the temperature range of -30°C to 70°C , at a relative humidity of $\pm 50\%$
- 5-2** Overall echo sensitivity shall not change by more than $\pm 3\text{dB}$ in the humidity range of 10% to 90% at the temperature of 25°C
- 5-3** Overall echo sensitivity shall be within $\pm 3\text{dB}$ of the specified values after the device is subjected to any or all of the belows
 - 5-3-1** Operation at 90% relative humidity and 40°C for 100 hours, followed by a normalization period of 24 hours at 30% and 25°C
 - 5-3-2** Storage at -40°C to $+80^{\circ}\text{C}$ for 24 hours followed by a normalization period of an hour at 25°C
 - 5-3-3** Vibration at 10 to 55Hz, 1.5mm amplitude. 1 minute sweep. X, Y, Z, 3 each axis for 3 hours.
 - 5-3-4** Shock: After impact of 50G is applied following. X, Y, Z, 3 axis /3 cycle / each direction.
 - 5-3-5** Drop: After free drop from 1 meter height onto concrete floor, 3 times

6 Mechanical Characteristics

Lead strength

To pull longitudinally 1.0 kgf min.

To push longitudinally 1.0 kgf min.

7 Warranty

- 7-1** Warranty period is one year after delivery
- 7-2** Defective transducers attributable to manufacturer's responsibility shall be replaced for free, during the warranty period. However, following cases are out of the this replacement.
 - 7-2-1** Unsuitable handling or misuse by user.
 - 7-2-2** Modification or repair by user.
 - 7-2-3** Any other cases not responsible for manufacturer such as natural calamity, accident, etc.

This warranty covers only replacement. Any loss derived from failure or malfunction of the transducer, or cost to replace is excluded from this warranty.

Dimensions: unit mm

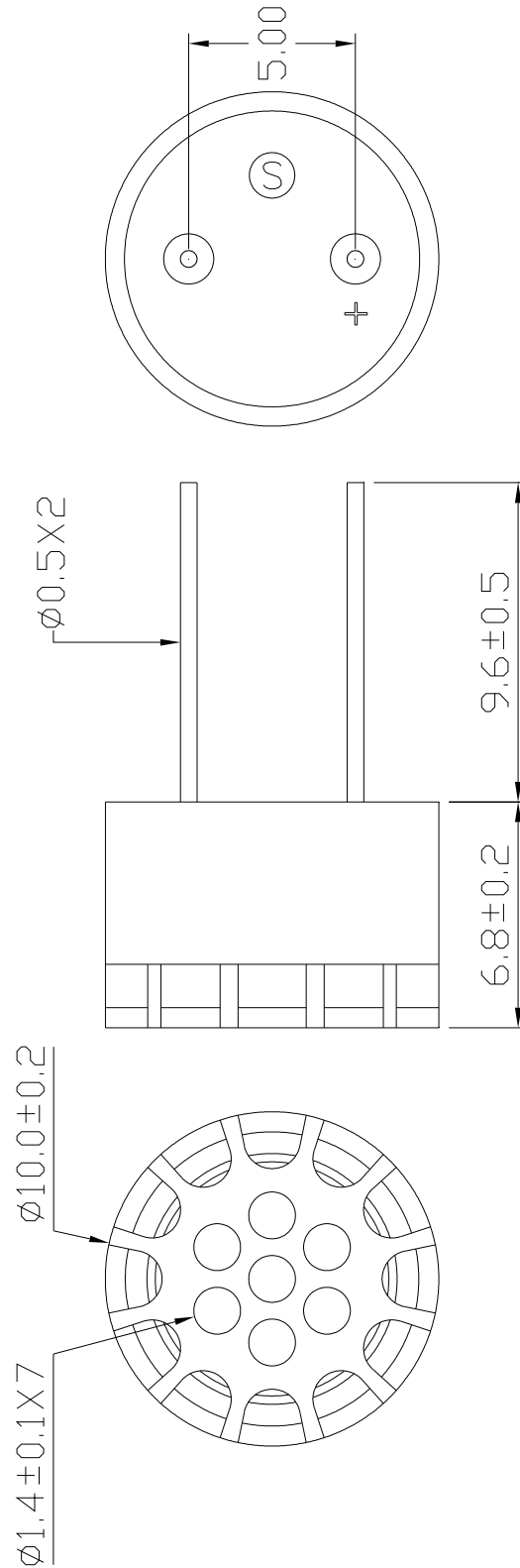

Figure 1

Test Circuit:

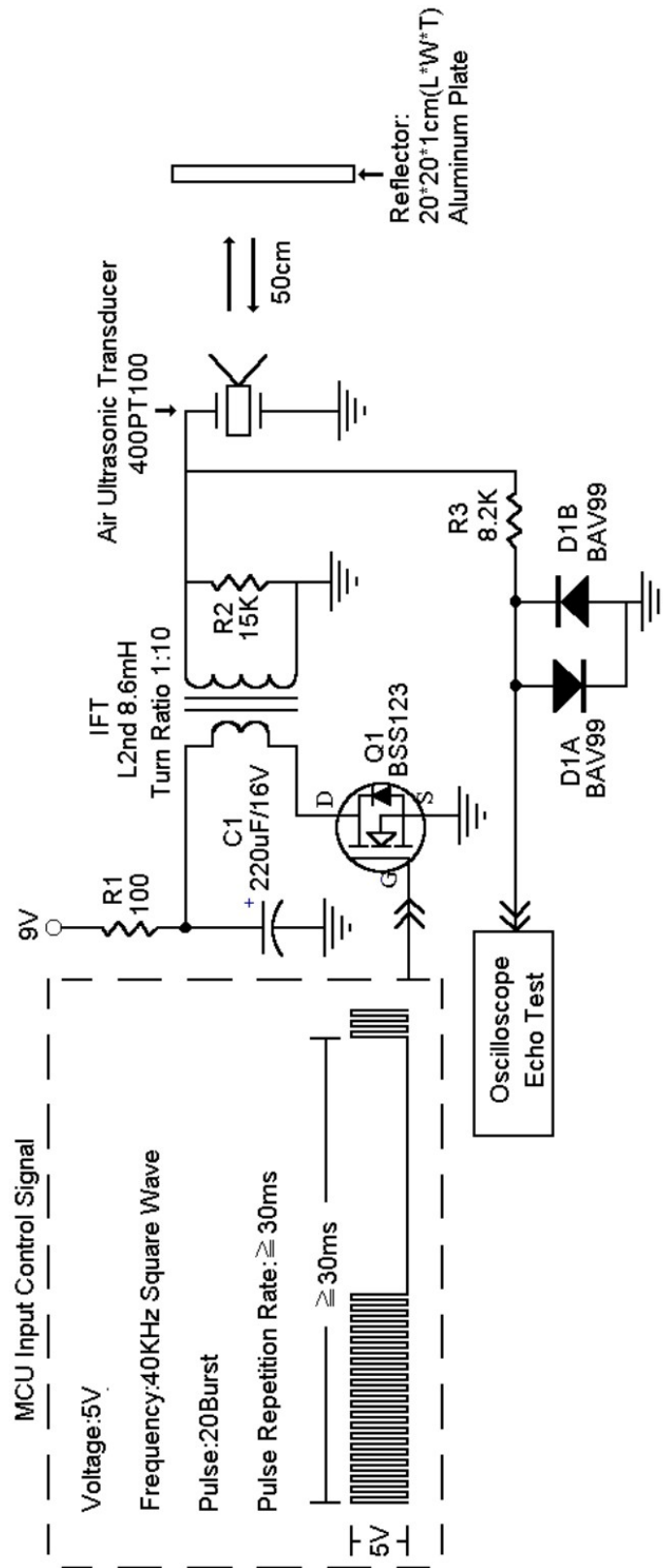

Figure 2

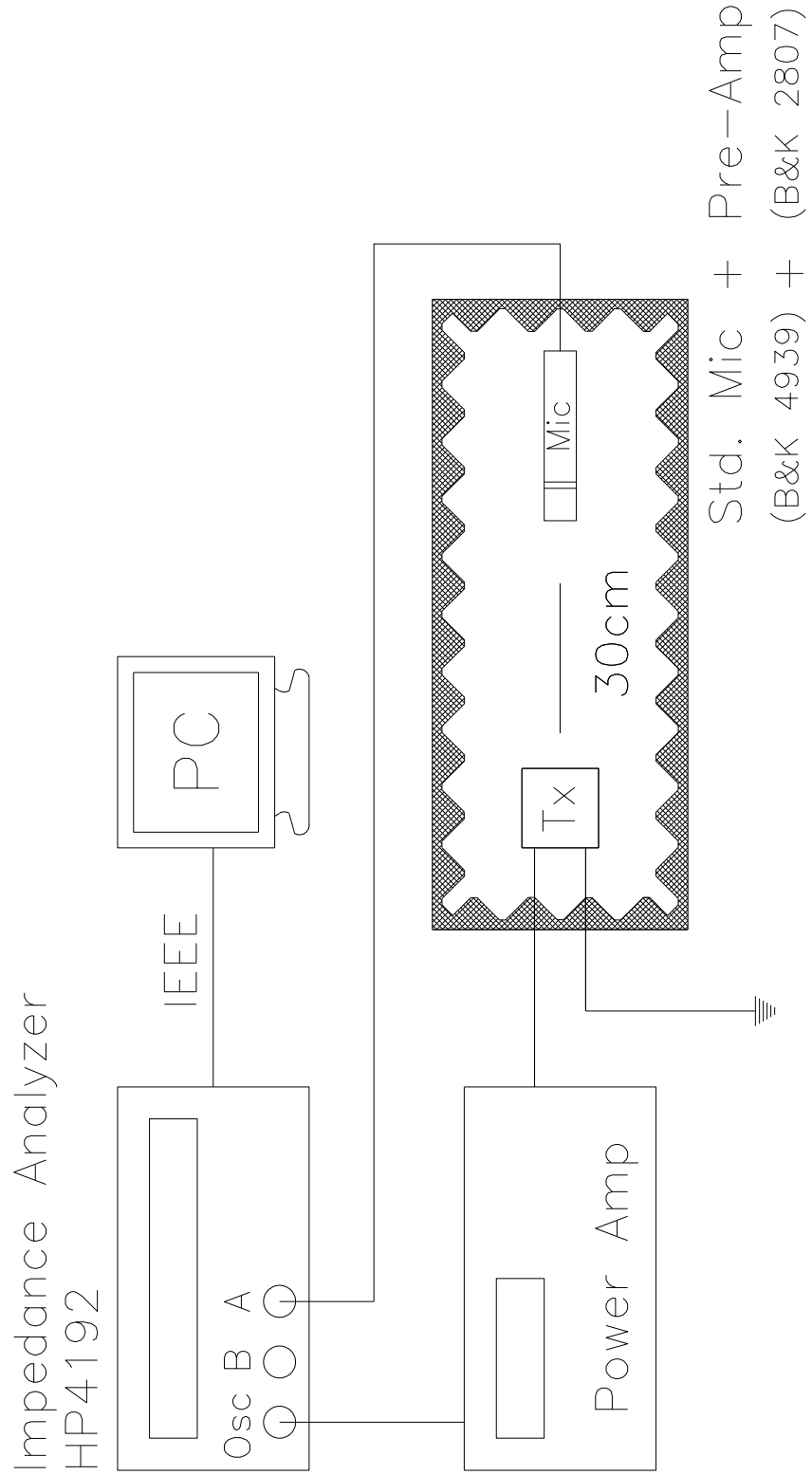

Figure 3

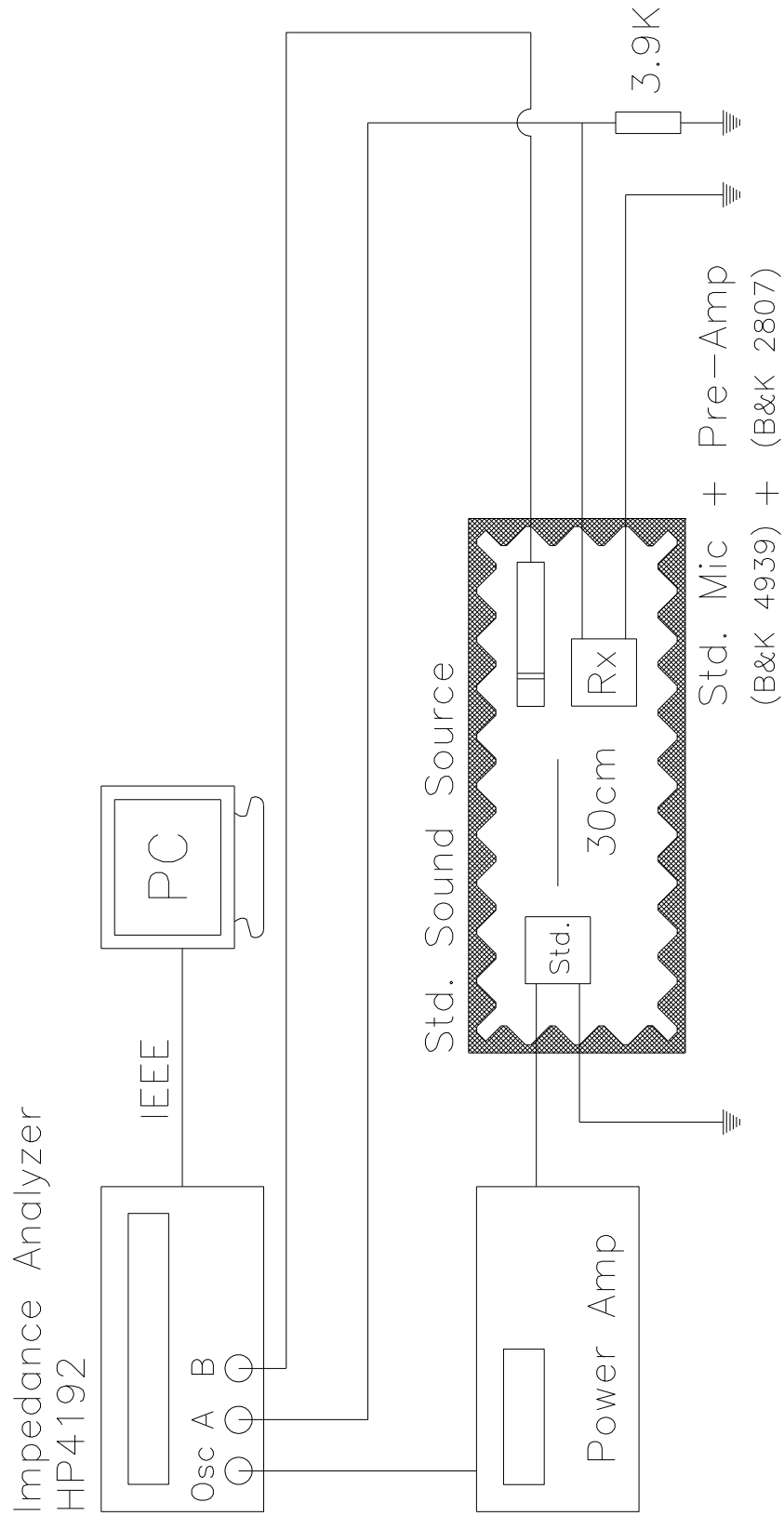

Figure 4