

IrDA PROTO™

Manual

All Mikroelektronika's development systems feature a large number of peripheral modules expanding microcontroller's range of application and making the process of program testing easier. In addition to these modules, it is also possible to use numerous additional modules linked to the development system through the I/O port connectors. Some of these additional modules can operate as stand-alone devices without being connected to the microcontroller.

Additional Board

 **MikroElektronika**

SOFTWARE AND HARDWARE SOLUTIONS FOR EMBEDDED WORLD ...making it simple

IrDA PROTO Additional Board

The *IrDA PROTO* additional board is used for wireless communication carried out via infrared waves. This board includes an infrared transceiver modul TFDU4101 used for serial communication with devices transferring data via infrared waves such as printers, fax machines, notebooks, industrial devices, etc. The MCP2155 circuit provided on the board is used to convert data received from the transceiver module and send it to the microcontroller for further processing. The *IrDA PROTO* board communicates with a microcontroller via serial communication UART.

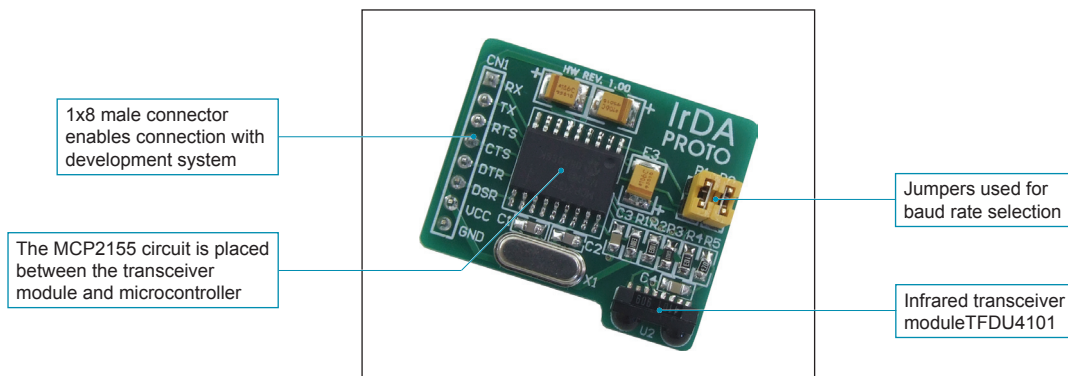

Figure 1: IrDA PROTO additional board

The *IrDA PROTO* additional board is connected with a microcontroller via a 1x8 male connector. The TFDU4101 infrared transceiver module can send and receive data in the scope of over 1m at a rate of up to 115.2kbit/s. The baud rate depends on the MCP2155 circuit and position of jumpers B1 and B0. Refer to the table on the right.

Labels used in the table have the following meaning:

- E - Jumper is placed (Enable)
- D - Jumper is removed (Disable)

| Baud rate selection | | |
|---------------------|----|--------------|
| Jumper position | | Baud rate |
| B1 | B0 | |
| E | E | 9.6 kbit/s |
| E | D | 19.2 kbit/s |
| D | E | 57.6 kbit/s |
| D | D | 115.2 kbit/s |

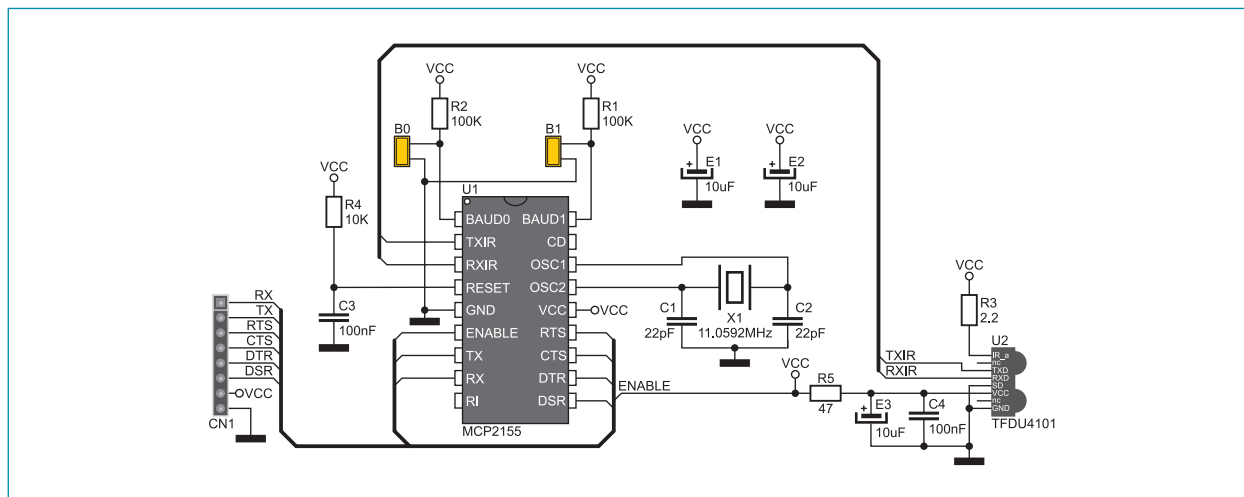

Figure 2: Additional board IrDA PROTO connection schematic

The function of the pins provided on the 1x8 male connector CN1:

- RX - Receive data pin
- TX - Transmit data pin
- RTS - Request to send
- CTS - Clear to send
- DTR - Data terminal ready
- DSR - Data set ready

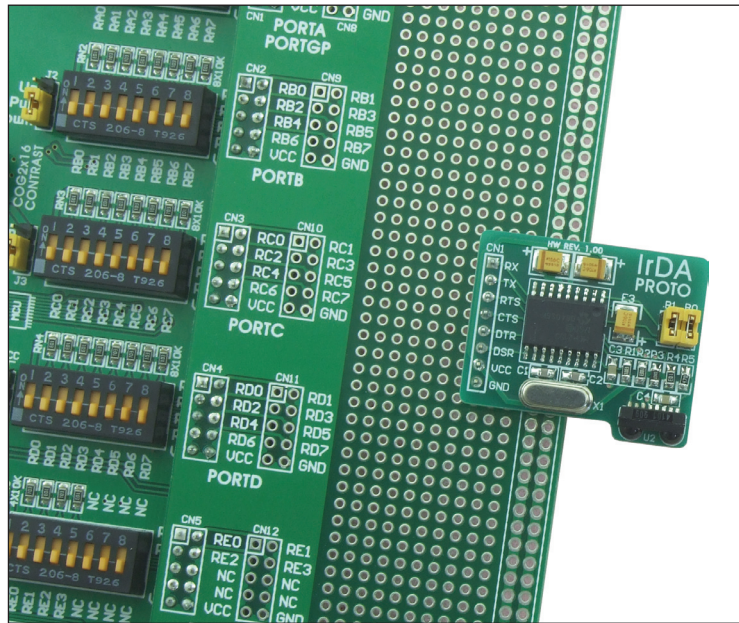

Figure 3: IrDA PROTO board connected to a development system by using a proto board



MikroElektronika
SOFTWARE AND HARDWARE SOLUTIONS FOR EMBEDDED WORLD ...making it simple

If you want to learn more about our products, please visit our website at www.mikroe.com

If you are experiencing some problems with any of our products or just need additional information, please place your ticket at www.mikroe.com/en/support

If you have any questions, comments or business proposals, do not hesitate to contact us at office@mikroe.com

Mouser Electronics

Authorized Distributor

Click to View Pricing, Inventory, Delivery & Lifecycle Information:

[mikroElektronika:](#)

[MIKROE-325](#)