

## **AN-2062 LM3549 Evaluation Kit**

---

---

---

### **1 General Description**

The LM3549 is a high power LED driver with up to 700mA output current. It has three constant current LED drivers and a buck boost SMPS for driving RGB LEDs with high efficiency. LED drivers are designed for sequential drive so only one driver can be enabled at a time.

LED driver output current settings can be stored to integrated non-volatile memory which allows stand-alone operation without I<sup>2</sup>C interface. Non-volatile memory is re-writable so current setting can be changed if needed.

LM3549 has a fault detection feature that can detect several different fault conditions. In case of a fault error flags are set and FAULT output sends interrupt to control logic. Error flags can be read through I<sup>2</sup>C interface.

Total brightness can be controlled with PWM input or with master fader register if I<sup>2</sup>C interface is used.

LM3549 evaluation board is designed to help getting familiarized with the LM3549. It can be used to measure key parameters of the LM3549 and to speed up design in of the device. The evaluation board has a microcontroller that acts as an USB to I<sup>2</sup>C interface. Microcontroller is also used to manipulate the digital control signals of the LM3549. LM3549 evaluation board can be powered from the USB interface or from external power supply. If evaluation board is used to measure the electrical parameters of the LM3549 or used with high output currents external power supply needs to be used. If evaluation board is used to check the functionality of the LM3549 with small output currents or to support software development it can be powered directly from USB interface. This document describes how to get the LM3549 evaluation board up and running and how to use evaluation software.

### **2 What Is Needed**

To get started you will need:

- LM3549 evaluation board
- LM3549 evaluation software (LM3549.exe)
- USB cable
- PC with one free USB port

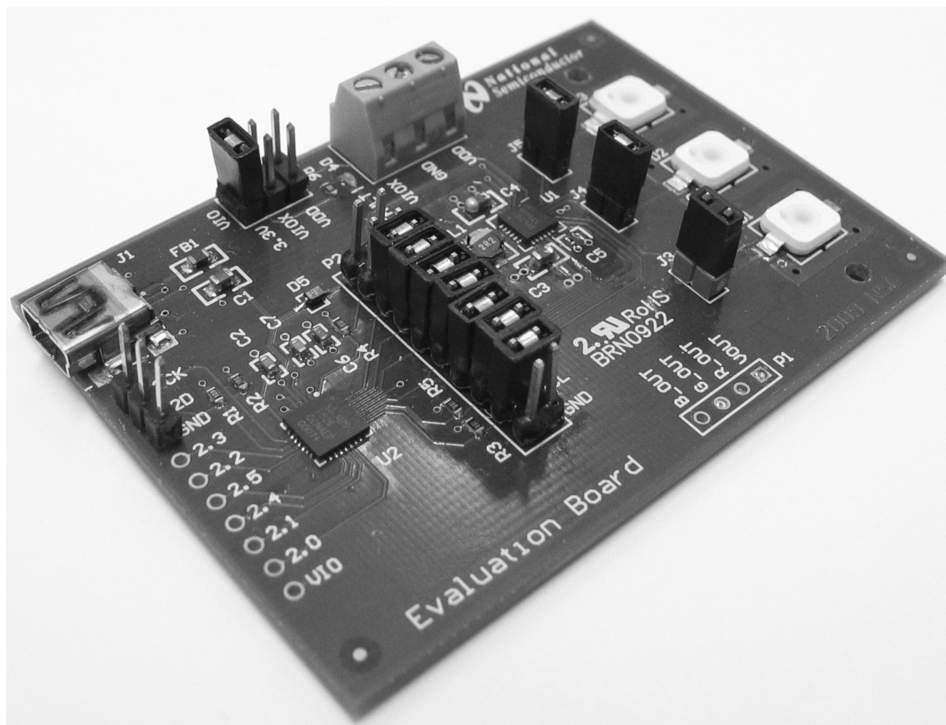
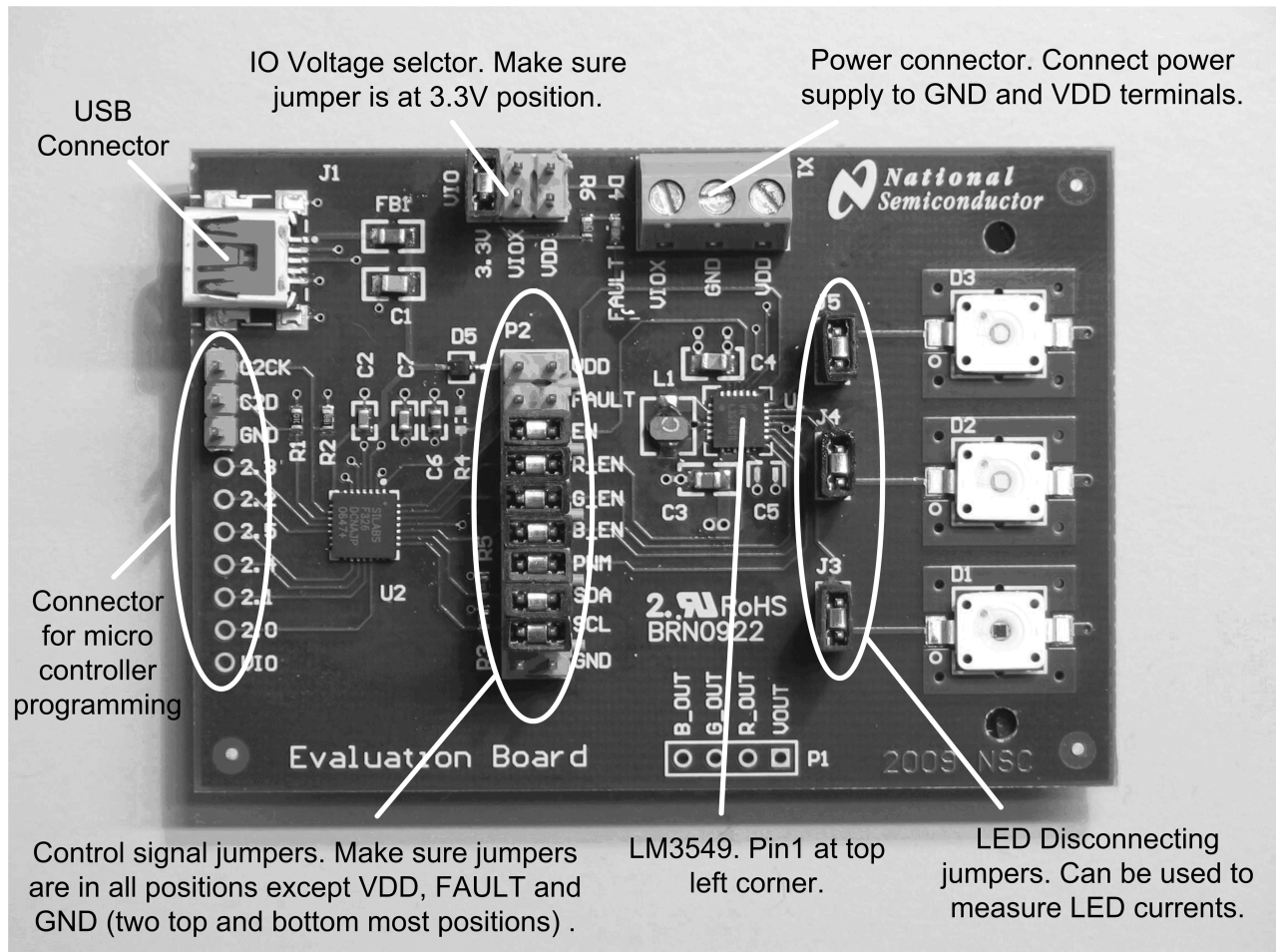

Figure 1. Evaluation Board

### 3 Hardware Set-Up



**Figure 2. LM3549 Evaluation Board Setup**

The LM3549 evaluation kit is based on a one board system, where the USB communication and evaluation related components are assembled onto one board, (see [Figure 2](#)). The evaluation board was designed especially for evaluation and, therefore, is not optimized for the smallest layout size. The components are physically large to make changing component values easier.

LM3549 input voltage VDD can be supplied from the USB port or by connecting an external power supply to the X1 connector. If voltage is supplied from USB port shunt needs to be placed on the VDD position of P2 pin rail. If external power supply is used this shunt needs to be removed. USB port's maximum output current is 500mA. This is not enough to drive the LEDs with maximum output current but can be used to test functionality of the LM3549.

[Figure 2](#) shows how to setup the LM3549 evaluation board. This configuration uses onboard microcontroller to control the LM3549's logic inputs. If one wishes to use external source to drive the control signals, control signal jumpers needs to be removed and external control signals needs to be connected to the right side of the P2 pin rail. Control signals are labeled for easy connection.

I<sup>2</sup>C interface pull-up resistors are placed on the microcontroller side of the control signal jumpers. If external I<sup>2</sup>C interface is connected to the board it needs to have pull-up resistors. LM3549 I<sup>2</sup>C ID is 36h (in 7bit format) -> write = 6Ch (8-bit format) and read = 6Dh (8-bit format)

The onboard microcontroller has USB interface to communicate with PC. Connect evaluation board to PC with USB cable. Evaluation software is used to control LM3549's logic inputs and to use the I2C interface. Evaluation software setup and use are described in the following sections

LM3549 evaluation board has three high current LEDs. These LED's are very bright even with minimum current setting. **Never look straight into the LEDs. This can damage your eyes!** It is good practice to always cover the LEDs with something to avoid looking straight into them.

### 3.1 Connector Listing

- J1 - USB connector. Use this to connect the LM3549 to your PC.
- VIO - selector for digital logic levels. There should be a shunt in 3.3V position.
- X1- power supply connector. VDD terminal can be used to supply LM3549 input voltage from external power supply. VIOX terminal can be used to connect external voltage for the digital signals.
- Connector for microcontroller programming is used to program the on-board microcontroller. This has no user functions and needs to always be unconnected.
- P2 - P2 pin rail is used to connect on-board microcontroller to LM3549 digital lines. If you want to connect LM3549 to your own system, shunts can be removed and your system can be connected to the right side pins of the P2 pin rail.
- J3, J4 and J5 - LED disconnecting jumpers. These can be used to disconnect the LEDs from LM3549 LED outputs. This can be used to test the fault detection or to measure LED currents.
- P1 - Connector for VOUT and LED outputs. This can be used to connect external LEDs to the LM3549 evaluation board.

## 4 Connecting the Evaluation Board to a Computer

1. Check that the jumpers on the evaluation board are on wanted positions.
2. Connect external power supply to the evaluation board or, if evaluation board is to be powered form USB port, set shunt to VDD position of the P2 pin rail.
3. Connect the USB board to your computer using a USB cable
4. Start the evaluation software *LM3549.exe*
5. Evaluation software may prompt you to update firmware of the LM3549 evaluation board. If it does click ok and wait until update is completed.
6. Status bar at the center of the bottom row should say "OK" on green background. This indicates that I2C interface between microcontroller and LM3549 is working correctly.
7. The evaluation kit is now fully up and running and the device can be controlled through the PC software. [Figure 3](#) shows the evaluation software user interface (Control Panel).

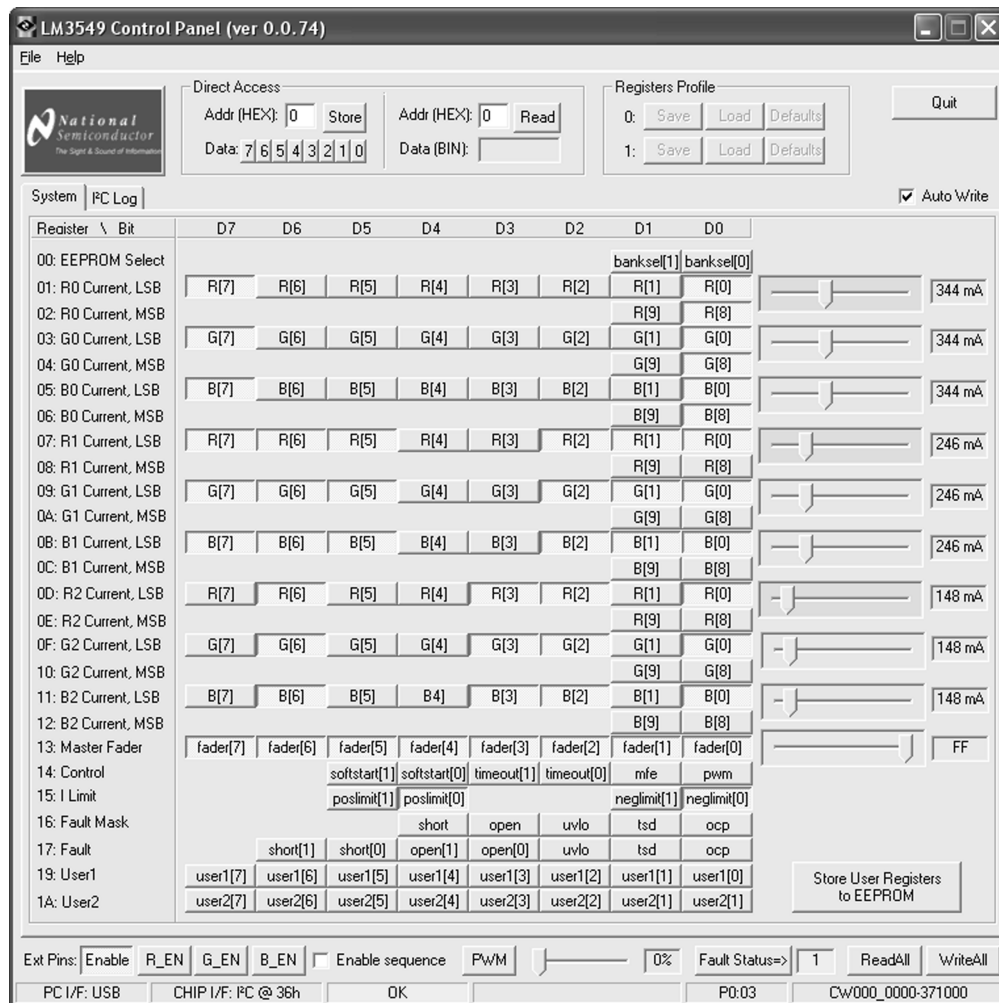

Figure 3. LM3549 Evaluation Software Control Panel

You should see USB OK message on the status bar (shown in the lower part of the window). If the USB communication is not working correctly, shut down the evaluation software and unplug the USB cable. Plug in the USB cable again and wait about 5 seconds and restart the evaluation software. You can also try toggling the Enable button few times.

## 5 Controlling the Evaluation Board

Evaluation software doesn't need installation and can be run by double clicking the icon. If evaluation board is set up correctly, the evaluation software's user interface should look like in Figure 3. When software starts up, it sets the Enable control to "1" and reads the control register values. The Status bar at the center of the bottom row should say OK on green background. This indicates that I2C interface between microcontroller and LM3549 is working correctly. If there are any error messages on red background something is wrong with the I2C interface. In this case, check the control signal jumpers and verify that proper VDD voltage is applied to the board.

The evaluation software provides read-write control over the registers within the LM3549. Bits can be set from a logical '1' to a logical '0' or vice versa by a mouse click and for some settings there is a slider control.

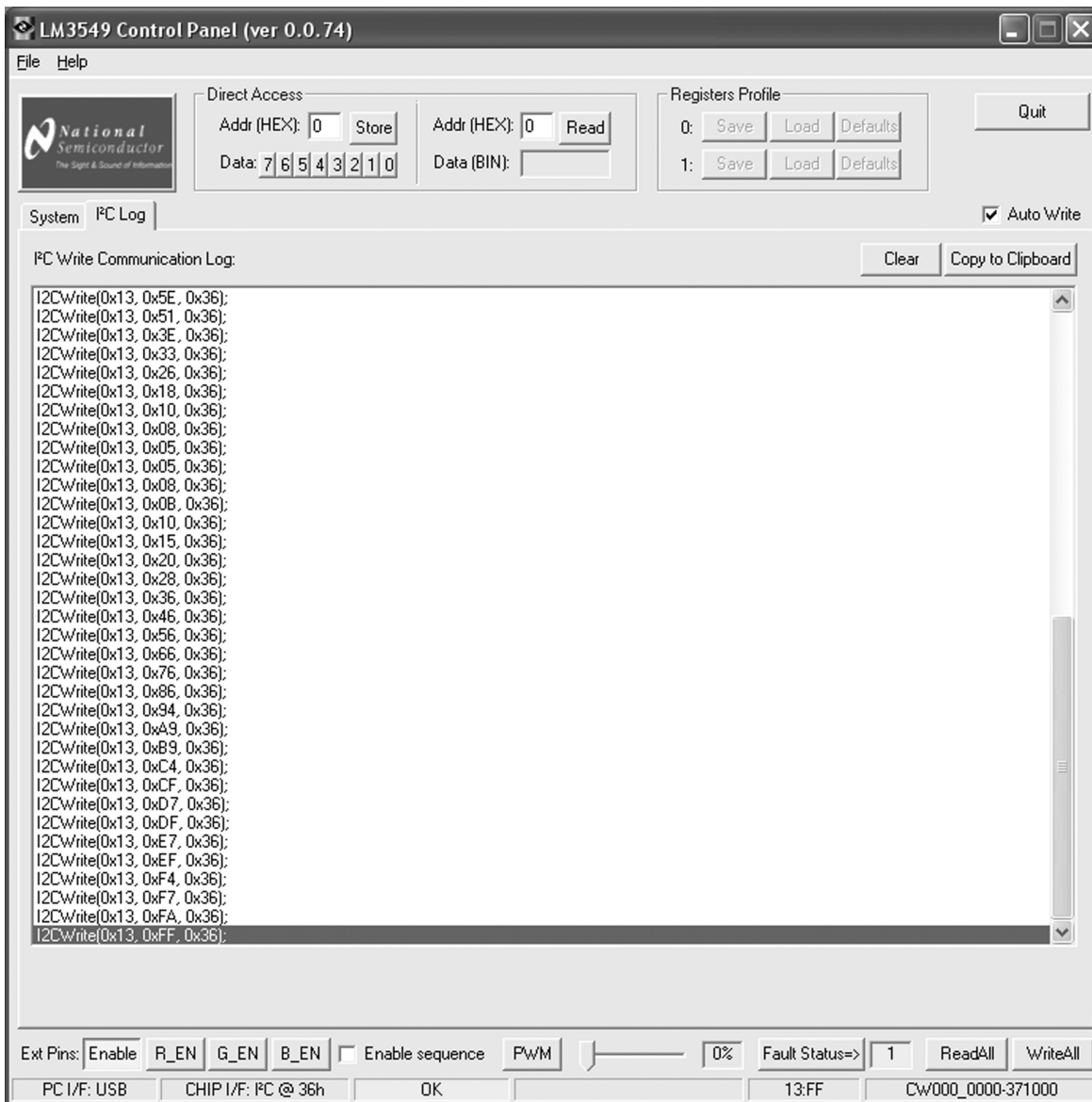

Figure 4. I<sup>2</sup>C Log View

Figure 4 shows the I<sup>2</sup>C Log tab of the evaluation software. All I<sup>2</sup>C write commands will be logged and can be seen on I<sup>2</sup>C Log tab. You can copy/paste write commands into his/her own application if needed.

### 5.1 I<sup>2</sup>C Communication

LM3549 registers 00h-16h and 19h – 1Ah are read/write accessible using controls (buttons and track bars where available) on System tab of the software window. Register 17h (Fault register) is read only register. Button ReadAll reads all register values of the LM3549 and updates register map related buttons and track bars according to results. Note that ReadAll button doesn't update external pin buttons. Button WriteAll stores values of buttons and track bars to LM3549. Note that specific register will be updated immediately when clicking/dragging on its control buttons or track bar if Auto Write checkbox is checked. I<sup>2</sup>C communication status after register read or write command are shown on status bar (at bottom of window).

## 5.2 Direct Access to Registers

Controls on the frame Direct Access allows you to read/write from/to the chip registers manually. Enter the register address to the Addr field and choose the binary value by clicking on the Data bits 7...0 and write the selected value to the chip register by clicking on the Store button. Note that after clicking the Store button all the register values will be read back automatically. Disable the automatic read by unchecking Auto Write checkbox. Enter the register address to the Addr field and click the Read button to read the specific register. The result will be displayed in the Data field in binary format.

## 5.3 Control Signals

Buttons Enable, R\_EN, G\_EN, B\_EN and PWM are used to manipulate input pins of the LM3549. Button Fault Status is used to read status of FAULT pin. Pin value appears to value bar beside the button.

Setting Enable button high puts LM3549 to standby mode. I2C registers can be read and written in standby mode but buck-boost converter and LED drivers are off. Setting Enable button low sets LM3549 to shutdown mode.

When device is on the standby mode LEDs can be turned on one at the time by clicking R\_EN, G\_EN or B\_EN. Even if two or more buttons are turned high at the same time, only the LED that was set high first will be on.

Generation of special sequence of R, G and B signals can be enabled/disabled by checking/unchecking Enable sequence checkbox. Period of the sequence is about 60 Hz and is similar to that described in the *LM3549 High Power Sequential LED Driver Data Sheet* ([SNVS640](#)). Note that clicking on one of the R\_EN, G\_EN, B\_EN button will disable sequence generation automatically.

PWM generation can be enabled by dragging PWM track bar on bottom of the window. PWM frequency is about 7.6kHz.

## 5.4 EEPROM Programming

Desired default register values can be stored to EEPROM. These values are always read back to registers when Enable button is set from low to high. Keep the Enable button on and set all x\_EN buttons off and uncheck Enable sequence box. Write suitable values to all user registers. Set VDD to 5.0V and click on the Store User Registers to EEPROM button. Set the Enable button off and back to on. Read all registers by pressing the ReadAll button and verify that the values match with the stored values.

## 5.5 Fault LED

LED D4 is connected to LM3549's open drain fault output. If LM3549 detects any fault conditions e.g. LED short or LED open it pulls the fault output low and turns on the fault LED. LM3549 has a fault register which indicates what fault has occurred. Reading the fault register reset it's state and also reset the fault output to high-z state. Different fault conditions are described in the *LM3549 High Power Sequential LED Driver Data Sheet* ([SNVS640](#)).

6 Schematic

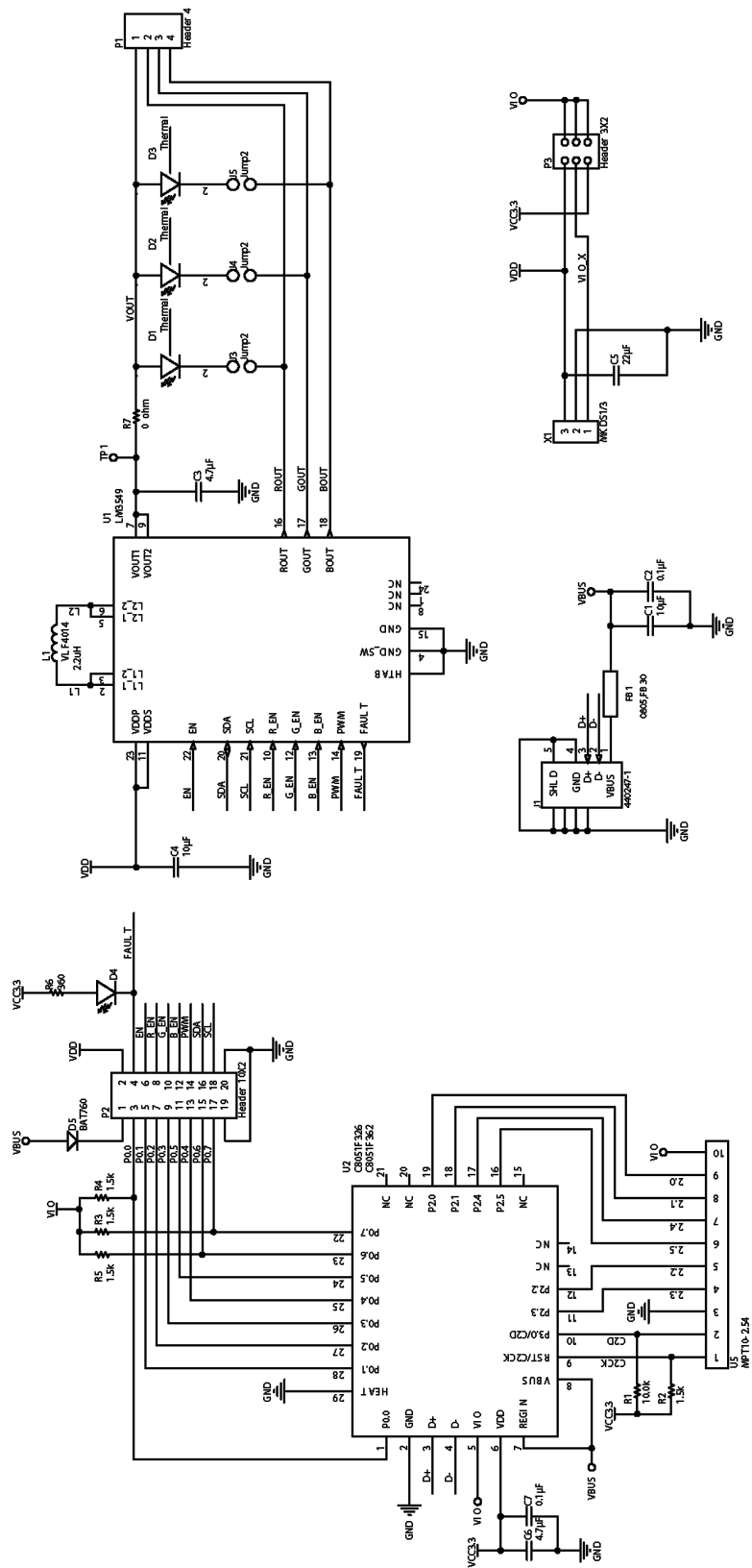

Figure 5. Schematic of the LM3549 Evaluation Board



## 7 Bill of Materials (BOM)

Designator	Value	Footprint	Comment	Description	Quantity
C1, C4	10 $\mu$ F	0805	Capacitor		2
C2, C7	100 nF	0805	Capacitor		2
C3	4.7 $\mu$ F	0805	Capacitor		1
C5	22 $\mu$ F	1210	Capacitor		1
C6	4.7 $\mu$ F	0603	Capacitor		1
D1	LR W5AP		Red LED	Osram Diamond Dragon LED	1
D2	LT W5AP		Green LED	Osram Diamond Dragon LED	1
D3	LD W5AP		Blue LED	Osram Diamond Dragon LED	1
D4	LS L296	0603 LED	Red LED	Fault indicator LED	1
D5	BAT760			Schotky diode	1
FB1	BK2125HS101-T	2125	Ferrite bead		1
L1	2.2 $\mu$ H		VLF4014ST-2r2M1R9	TDK SMD inductor	1
R1	10 k $\Omega$	0603	Resistor		1
R2, R3, R4, R5	1.5 k $\Omega$	0603	Resistor		4
R6	330 $\Omega$	0603	Resistor		1
R7	0 $\Omega$	0805	Resistor		1
U1	LM3549	LLP24			1
U2	C8051F326	QFN-28	Microcontroller		1

## IMPORTANT NOTICE

Texas Instruments Incorporated and its subsidiaries (TI) reserve the right to make corrections, enhancements, improvements and other changes to its semiconductor products and services per JESD46, latest issue, and to discontinue any product or service per JESD48, latest issue. Buyers should obtain the latest relevant information before placing orders and should verify that such information is current and complete. All semiconductor products (also referred to herein as "components") are sold subject to TI's terms and conditions of sale supplied at the time of order acknowledgment.

TI warrants performance of its components to the specifications applicable at the time of sale, in accordance with the warranty in TI's terms and conditions of sale of semiconductor products. Testing and other quality control techniques are used to the extent TI deems necessary to support this warranty. Except where mandated by applicable law, testing of all parameters of each component is not necessarily performed.

TI assumes no liability for applications assistance or the design of Buyers' products. Buyers are responsible for their products and applications using TI components. To minimize the risks associated with Buyers' products and applications, Buyers should provide adequate design and operating safeguards.

TI does not warrant or represent that any license, either express or implied, is granted under any patent right, copyright, mask work right, or other intellectual property right relating to any combination, machine, or process in which TI components or services are used. Information published by TI regarding third-party products or services does not constitute a license to use such products or services or a warranty or endorsement thereof. Use of such information may require a license from a third party under the patents or other intellectual property of the third party, or a license from TI under the patents or other intellectual property of TI.

Reproduction of significant portions of TI information in TI data books or data sheets is permissible only if reproduction is without alteration and is accompanied by all associated warranties, conditions, limitations, and notices. TI is not responsible or liable for such altered documentation. Information of third parties may be subject to additional restrictions.

Resale of TI components or services with statements different from or beyond the parameters stated by TI for that component or service voids all express and any implied warranties for the associated TI component or service and is an unfair and deceptive business practice. TI is not responsible or liable for any such statements.

Buyer acknowledges and agrees that it is solely responsible for compliance with all legal, regulatory and safety-related requirements concerning its products, and any use of TI components in its applications, notwithstanding any applications-related information or support that may be provided by TI. Buyer represents and agrees that it has all the necessary expertise to create and implement safeguards which anticipate dangerous consequences of failures, monitor failures and their consequences, lessen the likelihood of failures that might cause harm and take appropriate remedial actions. Buyer will fully indemnify TI and its representatives against any damages arising out of the use of any TI components in safety-critical applications.

In some cases, TI components may be promoted specifically to facilitate safety-related applications. With such components, TI's goal is to help enable customers to design and create their own end-product solutions that meet applicable functional safety standards and requirements. Nonetheless, such components are subject to these terms.

No TI components are authorized for use in FDA Class III (or similar life-critical medical equipment) unless authorized officers of the parties have executed a special agreement specifically governing such use.

Only those TI components which TI has specifically designated as military grade or "enhanced plastic" are designed and intended for use in military/aerospace applications or environments. Buyer acknowledges and agrees that any military or aerospace use of TI components which have **not** been so designated is solely at the Buyer's risk, and that Buyer is solely responsible for compliance with all legal and regulatory requirements in connection with such use.

TI has specifically designated certain components as meeting ISO/TS16949 requirements, mainly for automotive use. In any case of use of non-designated products, TI will not be responsible for any failure to meet ISO/TS16949.

### Products

Audio	<a href="http://www.ti.com/audio">www.ti.com/audio</a>
Amplifiers	<a href="http://amplifier.ti.com">amplifier.ti.com</a>
Data Converters	<a href="http://dataconverter.ti.com">dataconverter.ti.com</a>
DLP® Products	<a href="http://www.dlp.com">www.dlp.com</a>
DSP	<a href="http://dsp.ti.com">dsp.ti.com</a>
Clocks and Timers	<a href="http://www.ti.com/clocks">www.ti.com/clocks</a>
Interface	<a href="http://interface.ti.com">interface.ti.com</a>
Logic	<a href="http://logic.ti.com">logic.ti.com</a>
Power Mgmt	<a href="http://power.ti.com">power.ti.com</a>
Microcontrollers	<a href="http://microcontroller.ti.com">microcontroller.ti.com</a>
RFID	<a href="http://www.ti-rfid.com">www.ti-rfid.com</a>
OMAP Applications Processors	<a href="http://www.ti.com/omap">www.ti.com/omap</a>
Wireless Connectivity	<a href="http://www.ti.com/wirelessconnectivity">www.ti.com/wirelessconnectivity</a>

### Applications

Automotive and Transportation	<a href="http://www.ti.com/automotive">www.ti.com/automotive</a>
Communications and Telecom	<a href="http://www.ti.com/communications">www.ti.com/communications</a>
Computers and Peripherals	<a href="http://www.ti.com/computers">www.ti.com/computers</a>
Consumer Electronics	<a href="http://www.ti.com/consumer-apps">www.ti.com/consumer-apps</a>
Energy and Lighting	<a href="http://www.ti.com/energy">www.ti.com/energy</a>
Industrial	<a href="http://www.ti.com/industrial">www.ti.com/industrial</a>
Medical	<a href="http://www.ti.com/medical">www.ti.com/medical</a>
Security	<a href="http://www.ti.com/security">www.ti.com/security</a>
Space, Avionics and Defense	<a href="http://www.ti.com/space-avionics-defense">www.ti.com/space-avionics-defense</a>
Video and Imaging	<a href="http://www.ti.com/video">www.ti.com/video</a>

### TI E2E Community

[e2e.ti.com](http://e2e.ti.com)