

NPN BU508DF

SILICON DIFFUSED POWER TRANSISTOR

The BU508DF is a NPN epitaxial-base transistor in TO3PFa package with integrated efficiency diode.

It is intended for high voltage, high-speed.

Primarily for use in horizontal deflection circuits of colour television receivers.

Compliance to RoHS.

ABSOLUTE MAXIMUM RATINGS

Symbol	Ratings	Value	Unit
V_{CBO}	Collector-Base Voltage	1500	V
V_{CEO}	Collector-Emitter Voltage	700	V
V_{EBO}	Emitter-Base Voltage	5	V
I_C	Collector Current	8	A
I_{CM}	Collector Current Peak	15	A
I_B	Base Current	4	A
I_{BM}	Base Current Peak	6	A
P_T	Total Dissipation @ $T_{mb} < 25^\circ$	34	W
t_J	Junction Temperature	150	°C
t_s	Storage Temperature range	-65 to +150	

THERMAL CHARACTERISTICS

Symbol	Ratings	Conditions	Value		Unit
			Typ.	Max	
R_{thJC}	Junction To Heatsink	Without Heatsink Compound	-	3.7	K/W
	Junction To Heatsink	With Heatsink Compound	-	2.8	
	Junction Ambient	In Free Air	35	-	

NPN BU508DF

ELECTRICAL CHARACTERISTICS

TC=25°C unless otherwise noted

Symbol	Ratings	Test Condition(s)	Min	Typ	Max	Unit
V_{CEO}	Collector-Emitter Breakdown Voltage	$I_C = 100 \text{ mA}$, $I_B = 0$ $L = 25 \text{ mH}$	700	-	-	V
I_{CES}	Collector Cutoff Current	$V_{BE} = 0$, $V_{CE} = 1500 \text{ V}$	-	-	1	mA
		$V_{BE} = 0$, $V_{CE} = 1500 \text{ V}$ $T_j = 125^\circ\text{C}$	-	-	2	
I_{EBO}	Emitter Cutoff Current	$V_{EB} = 5 \text{ V}$, $I_C = 0$	-	-	300	mA
$V_{CE(SAT)}$	Collector-Emitter saturation Voltage	$I_C = 4.5 \text{ A}$, $I_B = 1.6 \text{ A}$	-	-	1	V
$V_{BE(SAT)}$	Base-Emitter saturation Voltage	$I_C = 4.5 \text{ A}$, $I_B = 2 \text{ A}$	-	-	1.1	
V_F	Diode Forwardvoltage	$I_F = 4.5 \text{ A}$	-	1.6	2	V
h_{FE}	DC Current Gain	$I_C = 500 \text{ mA}$, $V_{CE} = 5 \text{ V}$	10	-	30	-
C_{OB}	Output Capacitance	$V_{CB} = 10 \text{ V}$, $I_E = 0$, $f = 1 \text{ MHz}$	3	-	-	A
f_T	Transition Frequency	$V_{CE} = 5 \text{ V}$, $I_C = 100 \text{ mA}$	-	7	-	MHz

NPN BU508DF

MECHANICAL DATA CASE TO3PFa

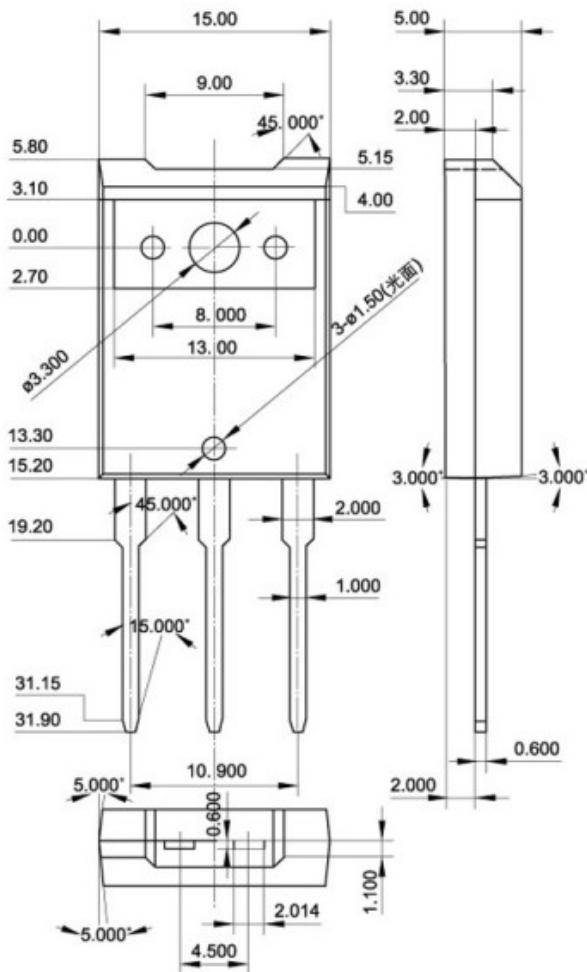

Pin 1 :	Base
Pin 2 :	Collector
Case :	Emitter
Case :	Isolated

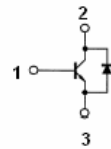

Revised October 2012

Information furnished is believed to be accurate and reliable. However, Comset Semiconductors assumes no responsibility for the consequences of use of such information nor for any infringement of patents or other rights of third parties which may result from its use. Data are subject to change without notice. Comset Semiconductors makes no warranty, representation or guarantee regarding the suitability of its products for any particular purpose, nor does Comset Semiconductors assume any liability arising out of the application or use of any product and specifically disclaims any and all liability, including without limitation consequential or incidental damages. Comset Semiconductors' products are not authorized for use as critical components in life support devices or systems.