

ENG NO.	FINISH
7859-1024	TIN OVERALL

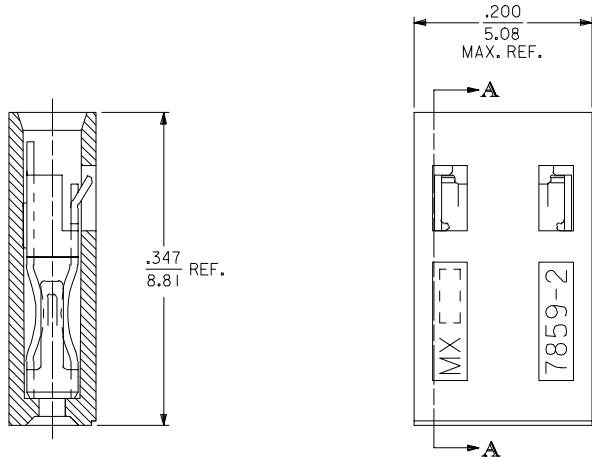

SECTION A-A

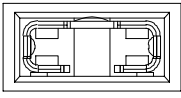
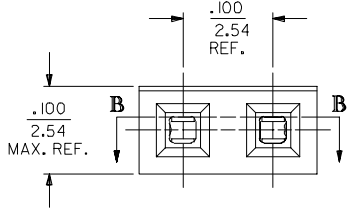

FINISH SPECIFICATION

TIN OVERALL - .000150 MINIMUM TIN PLATE OVER
 .000050 MINIMUM NICKEL UNDERPLATE.
 15 GOLD - .000015 MINIMUM GOLD PLATE IN SELECT AREA OVER
 .000050 MINIMUM NICKEL UNDERPLATE OVERALL.
 30 GOLD - .000030 MINIMUM GOLD PLATE IN SELECT AREA OVER
 .000050 MINIMUM NICKEL UNDERPLATE OVERALL.

PART IDENTIFICATION:

7859-102*
 └ PLATING SPECIFICATION

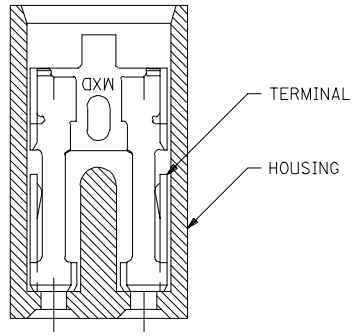

SECTION B-B

NOTES:

- MATERIAL:
 HOUSING: GLASS FILLED POLYESTER: 94V-0: COLOR: BLACK
 TERMINAL: PHOSPHOR BRONZE ALLOY
- THIS PRODUCT CONFORMS TO MOLEX PRODUCT SPEC:
 PS-7859.
- TO BE USED WITH: .025/0.64 SQUARE PINS.
- MINIMUM MATING PIN LENGTH: .200/5.08.
- PRODUCT IN PACKAGED IN BOXES PER PK-70873-0815.

INITIAL RELEASE FC NO: UCP2006-1496 DRAWNSMART 2006/01/17 CHKD:BBARKER 2006/01/17 APPR:SMILLER 2006/01/19 REV: A	DESCRIPTION QUALITY SYMBOLS ▽=0 ▽=0	GENERAL TOLERANCES (UNLESS SPECIFIED) mm INCH 4 PLACES ± --- ± --- 3 PLACES ± --- ± .005 2 PLACES ± 0.13 ± .01 1 PLACE ± 0.25 ± --- ANGULAR ±1/2°	DIMENSION STYLE IN/MM DRAWN BY DATE BSMART 12/29/2005 CHECKED BY DATE BBARKER 12/29/2005 APPROVED BY DATE SMILLER 12/29/2005	SCALE 4:1 DESIGN UNITS INCH THIRD ANGLE PROJECTION	TITLE SALES ASSEMBLY 2 CIRCUIT SHUNT TERMINAL W/OPEN END	MATERIAL NO. SEE TABLE SIZE C	DOCUMENT NO. SD-7859-002	SHEET NO. 1 OF 1
		DRAFT WHERE APPLICABLE MUST REMAIN WITHIN DIMENSIONS THIS DRAWING CONTAINS INFORMATION THAT IS PROPRIETARY TO MOLEX INCORPORATED AND SHOULD NOT BE USED WITHOUT WRITTEN PERMISSION						