

Switching Regulator IC for Buck Converter

Current Mode Control w/ 40V/1A MOSFET

■ GENERAL DESCRIPTION

The **NJW4153** is a buck converter with **40V/1A** MOSFET. It corresponds to high oscillating frequency, and Low ESR Output Capacitor (MLCC) within wide input range from 4.6V to 40V. Therefore, the **NJW4153** can realize downsizing of applications with a few external parts so that adopts current mode control.

Also, it has a soft start function, an over current protection and a thermal shutdown circuit.

It is suitable for power supply circuit of Micro Processor, DSP and so on that need fast transient response.

■ PACKAGE OUTLINE

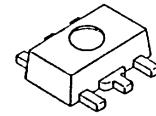

NJW4153U2

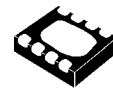

NJW4153KV1

■ FEATURES

- Current mode Control
- Maximum Rating Input Voltage 45V
- Wide Operating Voltage Range 4.6V to 40V
- Switching Current 1.4A min.
- PWM Control
- Built-in Compensation Circuit
- Correspond to Ceramic Capacitor (MLCC)
- Oscillating Frequency 1MHz typ. (A ver.)
- Soft Start Function 4ms typ.
- UVLO (Under Voltage Lockout)
- Over Current Protection (Hiccup type)
- Thermal Shutdown Protection
- Standby Function
- Package Outline NJW4153U2 : SOT-89-5
 NJW4153KV1 : ESON8-V1

■ PRODUCT CLASSIFICATION

Part Number	Version	Oscillation Frequency	Package	Operating Temperature Range
NJW4153U2-A	A	1MHz typ.	SOT-89-5	General Spec. -40°C to +85°C
NJW4153KV1-A	A	1MHz typ.	ESON8-V1	General Spec. -40°C to +85°C

NJW4153

■ PIN CONFIGURATION

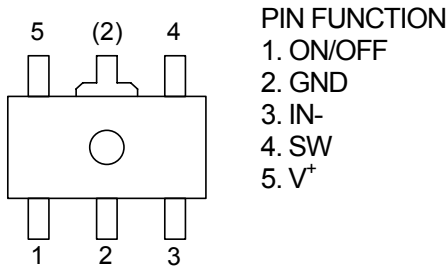

NJW4153U2

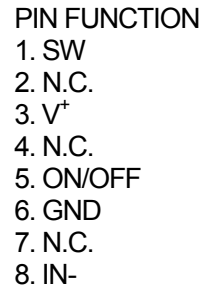
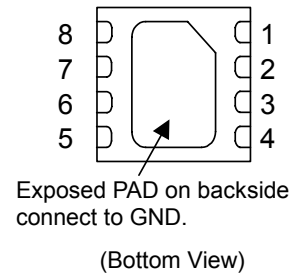
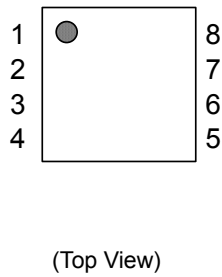

NJW4153KV1

■ BLOCK DIAGRAM

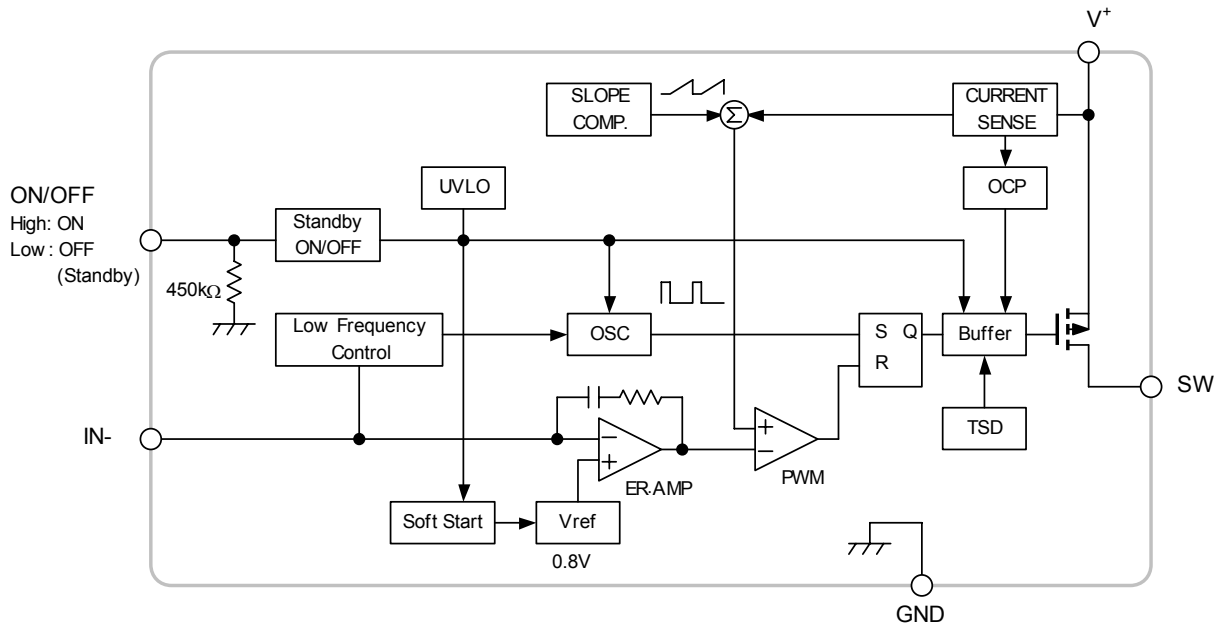

■ ABSOLUTE MAXIMUM RATINGS

(Ta=25°C)

PARAMETER	SYMBOL	MAXIMUM RATINGS	UNIT
Supply Voltage	V ⁺	+45	V
V ⁺ - SW pin Voltage	V _{V-SW}	+45	V
IN- pin Voltage	V _{IN-}	-0.3 to +6	V
ON/OFF pin Voltage	V _{ON/OFF}	+45	V
Power Dissipation	P _D	SOT-89-5 625 (*1) 2,400 (*2) ESON8-V1 600 (*3) 1,800 (*4)	mW
Junction Temperature Range	T _j	-40 to +150	°C
Operating Temperature Range	T _{opr}	-40 to +85	°C
Storage Temperature Range	T _{stg}	-40 to +150	°C

(*1): Mounted on glass epoxy board. (76.2×114.3×1.6mm:based on EIA/JDEC standard size, 2Layers, Cu area 100mm²)

(*2): Mounted on glass epoxy board. (76.2×114.3×1.6mm:based on EIA/JDEC standard, 4Layers)

(For 4Layers: Applying 74.2×74.2mm inner Cu area and a thermal via hall to a board based on JEDEC standard JESD51-5)

(*3): Mounted on glass epoxy board. (101.5×114.5×1.6mm: based on EIA/JEDEC standard, 2Layers FR-4, with Exposed Pad)

(*4): Mounted on glass epoxy board. (101.5×114.5×1.6mm: based on EIA/JEDEC standard, 4Layers FR-4, with Exposed Pad)

(For 4Layers: Applying 99.5×99.5mm inner Cu area and a thermal via hole to a board based on JEDEC standard JESD51-5)

■ RECOMMENDED OPERATING CONDITIONS

PARAMETER	SYMBOL	MIN.	TYP.	MAX.	UNIT
Supply Voltage	V ⁺	4.6	—	40	V

NJW4153

■ ELECTRICAL CHARACTERISTICS

(Unless otherwise noted, $V^+=V_{ON/OFF}=12V$, $T_a=25^\circ C$)

PARAMETER	SYMBOL	TEST CONDITION	MIN.	TYP.	MAX.	UNIT
Under Voltage Lockout Block						
ON Threshold Voltage	V_{T_ON}	$V^+=L \rightarrow H$	4.3	4.45	4.6	V
OFF Threshold Voltage	V_{T_OFF}	$V^+=H \rightarrow L$	4.2	4.35	4.5	V
Hysteresis Voltage	V_{HYS}		70	100	–	mV
Soft Start Block						
Soft Start Time	T_{SS}	$V_B=0.75V$	2	4	8	ms
Oscillator Block						
Oscillation Frequency	f_{OSC}	A version, $V_{IN}=0.7V$	900	1,000	1,100	kHz
Oscillation Frequency (Low Frequency Control)	f_{OSC_LOW}	$V_{IN}=0.4V$	–	370	–	kHz
Oscillation Frequency deviation (Supply voltage)	f_{DV}	$V^+=4.6$ to $40V$	–	1	–	%
Oscillation Frequency deviation (Temperature)	f_{DT}	$T_a = -40^\circ C$ to $+85^\circ C$	–	5	–	%
Error Amplifier Block						
Reference Voltage	V_B		-1.0%	0.8	+1.0%	V
Input Bias Current	I_B		-0.1	–	+0.1	μA
PWM Compare Block						
Maximum Duty Cycle	M_{AXDUTY}	$V_{IN}=0.7V$	85	90	–	%
Minimum ON time	t_{ON-min}		–	140	180	ns
Over Current Protection Block						
Cool Down Time	t_{COOL}		–	8	–	ms
Output Block						
Output ON Resistance	R_{ON}	$I_{SW}=1A$	–	0.45	0.75	Ω
Switching Current Limit	I_{LIM}		1.4	1.9	2.4	A
SW Leak Current	I_{LEAK}	$V_{ON/OFF}=0V$, $V^+=45V$, $V_{SW}=0V$	–	–	1	μA
ON/OFF Block						
ON Control Voltage	V_{ON}	$V_{ON/OFF}=L \rightarrow H$	1.6	–	V^+	V
OFF Control Voltage	V_{OFF}	$V_{ON/OFF}=H \rightarrow L$	0	–	0.5	V
Pull-down Resistance	R_{PD}		–	450	–	$k\Omega$
General Characteristics						
Quiescent Current	I_{DD}	$R_L=no\ load$, $V_{IN}=0.7V$	–	3.9	4.4	mA
Standby Current	I_{DD_STB}	$V_{ON/OFF}=0V$	–	–	1	μA

■ TYPICAL APPLICATIONS

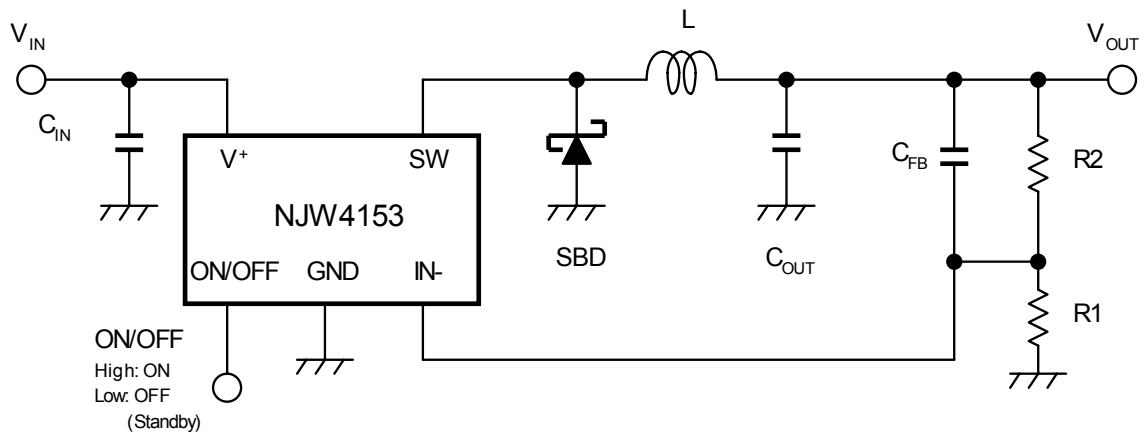

■ TYPICAL CHARACTERISTICS

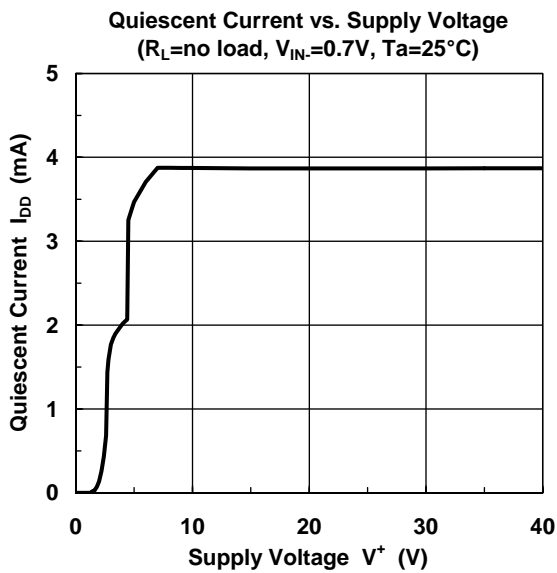
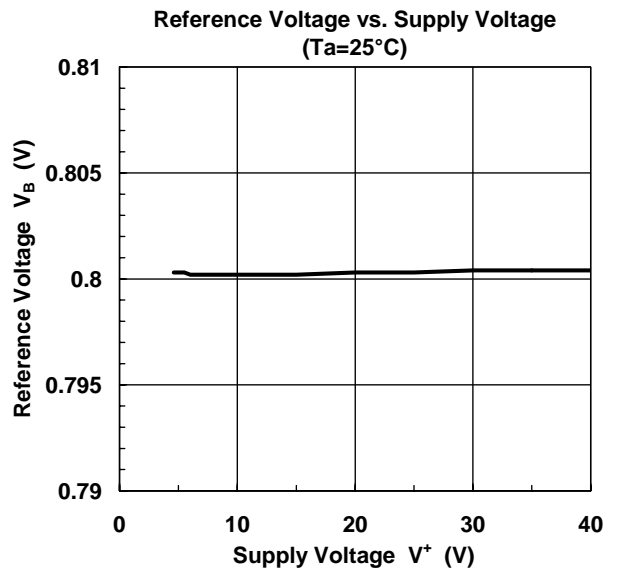
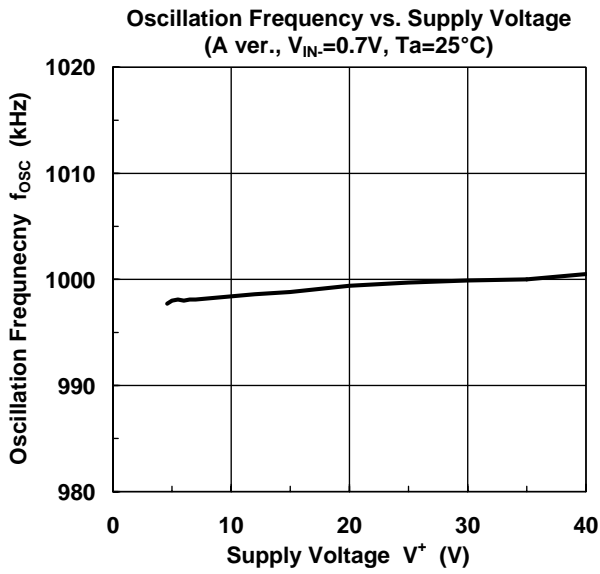

■ TYPICAL CHARACTERISTICS

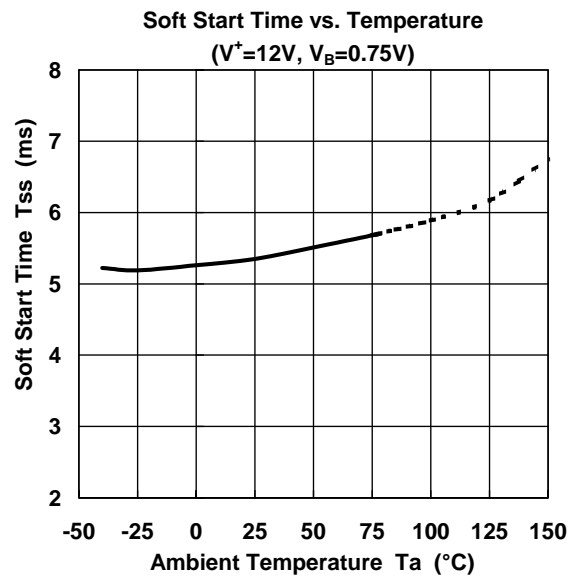
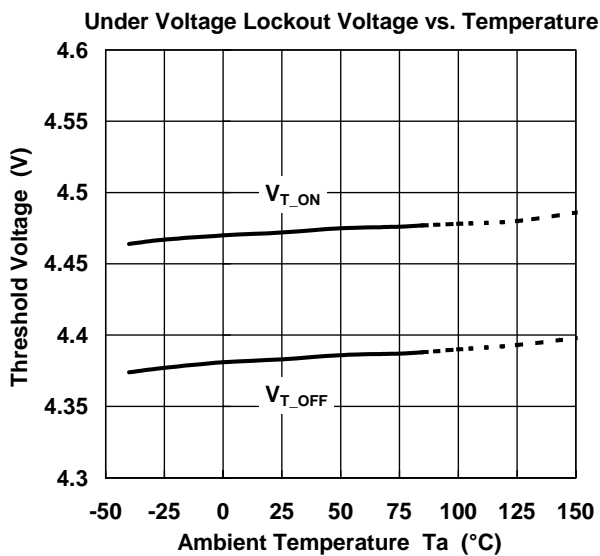
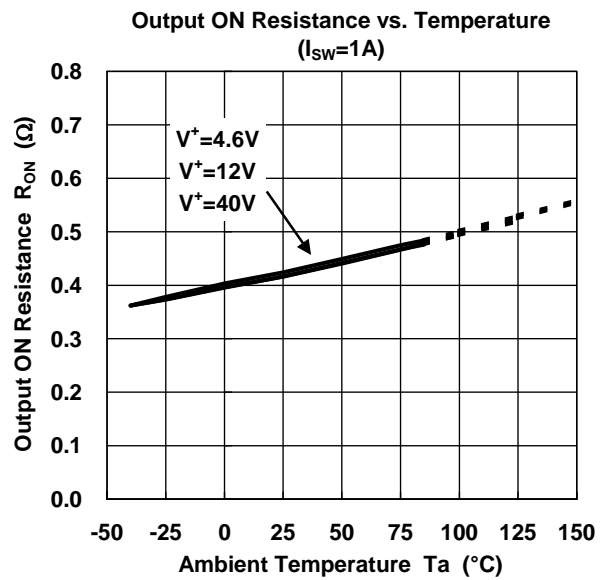
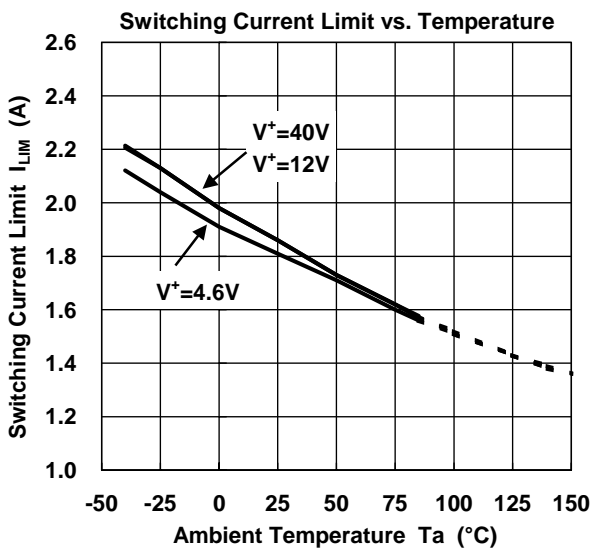
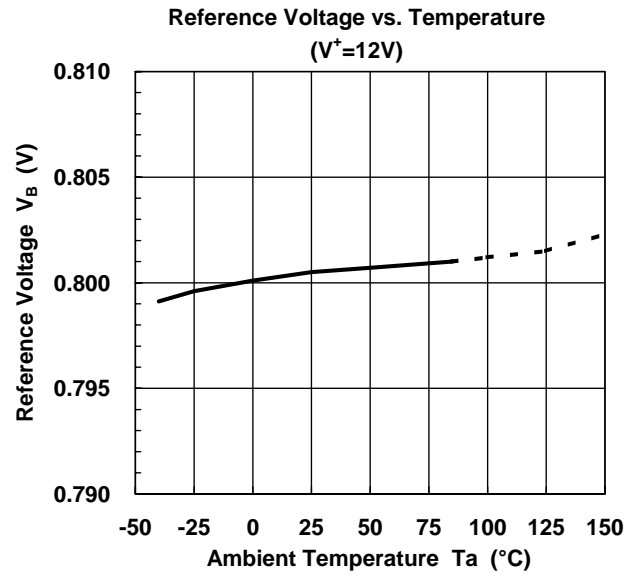
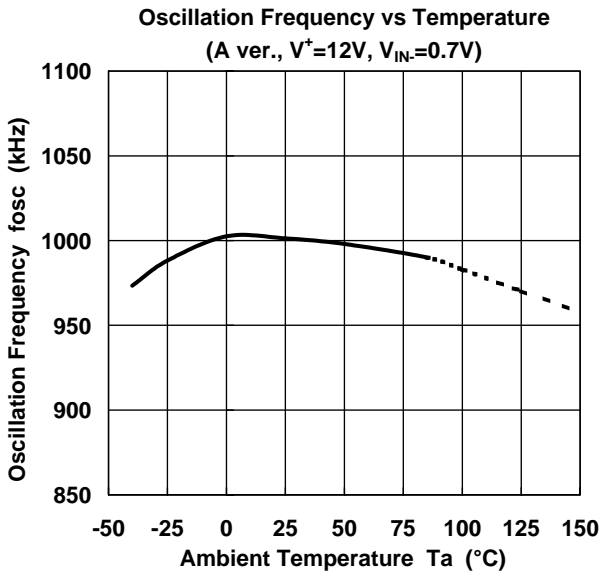

■ TYPICAL CHARACTERISTICS

Minimum ON Time vs. Temperature
($V^+=12V$)

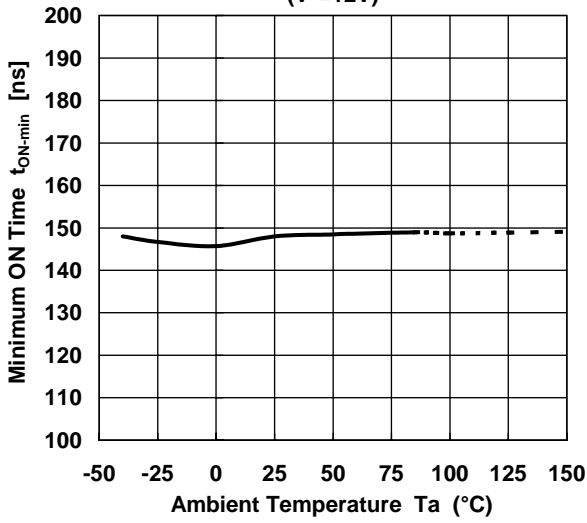

Maximum Duty Cycle vs. Temperature
($V^+=12V, V_{IN}=0.7V$)

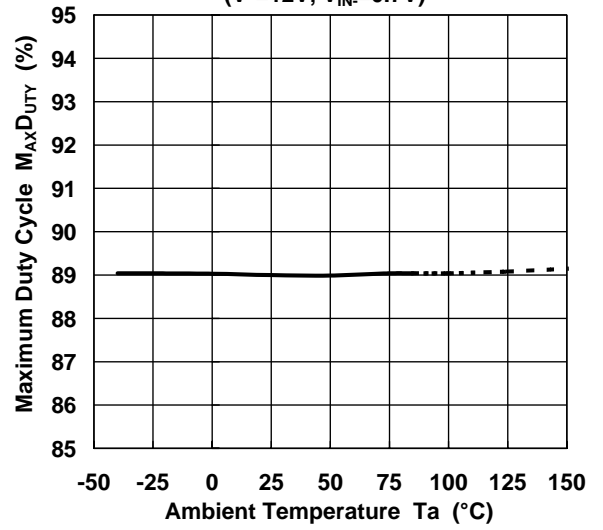

Quiescent Current vs. Temperature
($R_L=no\ load, V_{IN}=0.7V$)

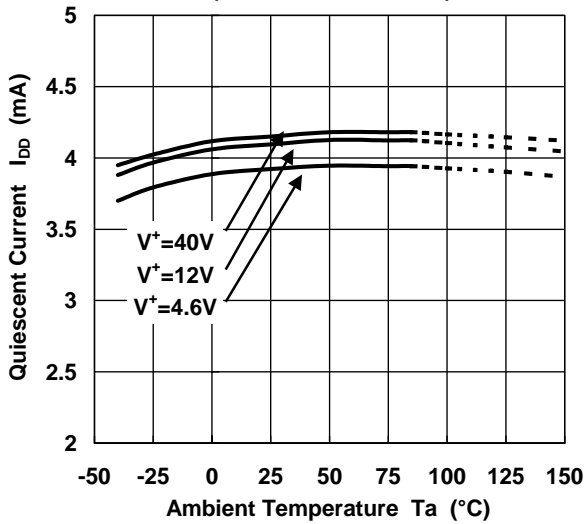

Standby Current vs. Temperature
($V_{ON/OFF}=0V$)

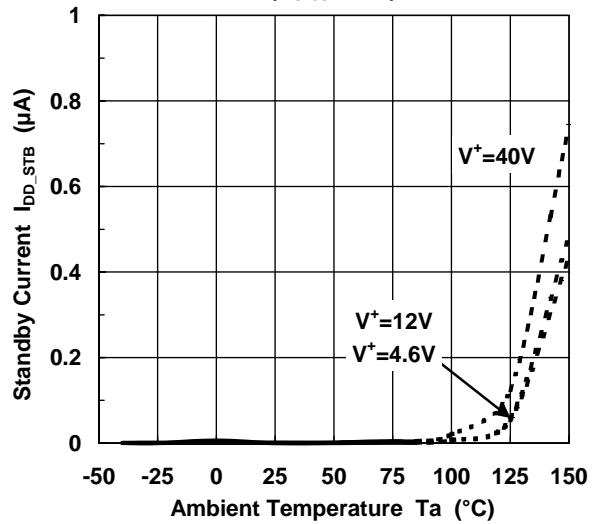

Switching Leak Current vs. Temperature
($V^+=45V, V_{ON/OFF}=0V, V_{SW}=0V$)

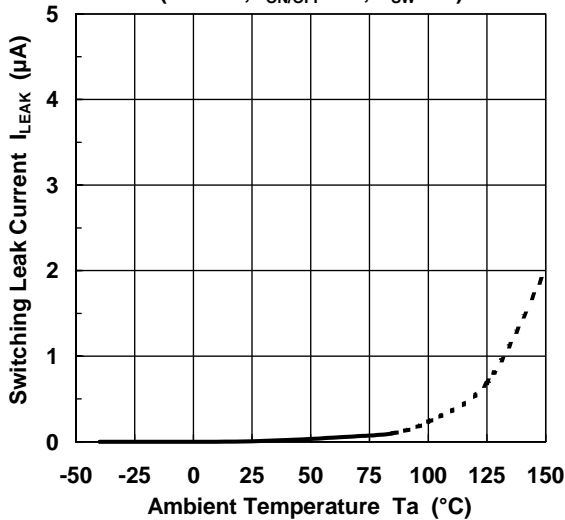

■ PIN DESCRIPTIONS

PIN NAME	PIN NUMBER		FUNCTION
	SOT-89-5	ESON8	
ON/OFF	1	5	ON/OFF Control pin The ON/OFF pin internally pulls down with 450kΩ. Normal Operation at the time of High Level. Standby Mode at the time of Low Level or OPEN.
GND	2	6	GND pin
IN-	3	8	Output Voltage Detecting pin Connects output voltage through the resistor divider tap to this pin in order to voltage of the IN- pin become 0.8V.
SW	4	1	Switch Output pin of Power MOSFET
V ⁺	5	3	Power Supply pin for Power Line
N.C.	–	2, 4, 7	Non connection
Exposed PAD	–	–	Connect to GND (Only ESOP8 PKG)

■ Description of Block Features

1. Basic Functions / Features

● Error Amplifier Section (ER-AMP)

0.8V±1% precise reference voltage is connected to the non-inverted input of this section.

To set the output voltage, connects converter's output to inverted input of this section (IN- pin). If requires output voltage over 0.8V, inserts resistor divider.

Because the optimized compensation circuit is built-in, the application circuit can be composed of minimum external parts.

● PWM Comparator Section (PWM), Oscillation Circuit Section (OSC)

The NJW4153 uses a constant frequency, current mode step down architecture. The oscillation frequency is 1,000kHz (typ.) at A version. The PWM signal is output by feedback of output voltage and slope compensation switching current at the PWM comparator block.

The maximum duty ratio is 90% (typ.).

The minimum ON time is limited to 140nsec (typ.).

The buck converter of ON time is decided the following formula.

$$t_{on} = \frac{V_{OUT}}{V_{IN} \times f_{OSC}} [s]$$

V_{IN} shows input voltage and V_{OUT} shows output voltage.

When the ON time becomes below in t_{ON-min} , in order to maintain output voltage at a stable state, change of duty or pulse skip operation may be performed.

● Power MOSFET (SW Output Section)

The power is stored in the inductor by the switch operation of built-in power MOSFET. The output current is limited to 1.4A(min.) the overcurrent protection function. In case of step-down converter, the forward direction bias voltage is generated with inductance current that flows into the external regenerative diode when MOSFET is turned off.

The SW pin allows voltage between the V^+ pin and the SW pin up to +45V. However, you should use an Schottky diode that has low saturation voltage.

● Power Supply, GND pin (V^+ and GND)

In line with switching element drive, current flows into the IC according to frequency. If the power supply impedance provided to the power supply circuit is high, it will not be possible to take advantage of IC performance due to input voltage fluctuation. Therefore insert a bypass capacitor close to the V^+ pin – the GND pin connection in order to lower high frequency impedance.

■ Description of Block Features (Continued)

2. Additional and Protection Functions / Features

● Under Voltage Lockout (UVLO)

The UVLO circuit operating is released above $V^+ = 4.45V$ (typ.) and IC operation starts. When power supply voltage is low, IC does not operate because the UVLO circuit operates. There is 100mV(typ.) width hysteresis voltage at rise and decay of power supply voltage. Hysteresis prevents the malfunction at the time of UVLO operating and releasing.

● Soft Start Function (Soft Start)

The output voltage of the converter gradually rises to a set value by the soft start function. The soft start time is 4ms (typ.). It is defined with the time of the error amplifier reference voltage becoming from 0V to 0.75V. The soft start circuit operates after the release UVLO and/or recovery from thermal shutdown. The operating frequency is controlled with a low frequency 370kHz, until voltage or the IN- pin becomes approximately 0.65V.

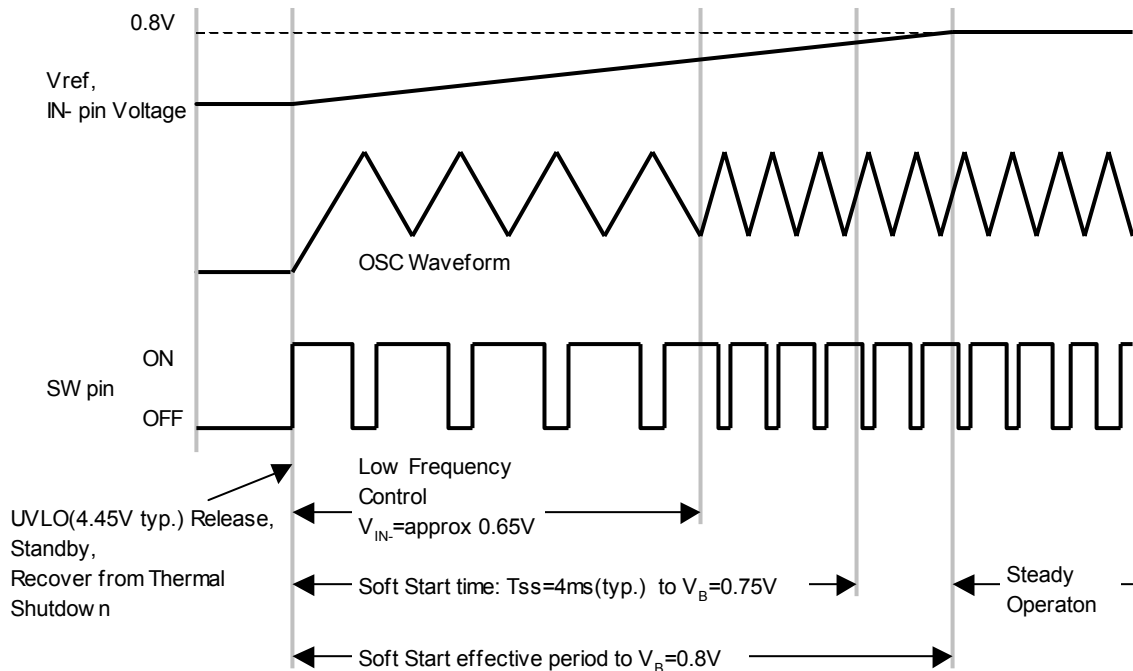

Fig. 1. Startup Timing Chart

■ Description of Block Features (Continued)

● Over Current Protection Circuit (OCP)

NJW4153 contains overcurrent protection circuit of hiccup architecture. The overcurrent protection circuit of hiccup architecture is able to decrease heat generation at the overload.

The NJW4153 output returns automatically along with release from the over current condition.

At when the switching current becomes I_{LIM} or more, the overcurrent protection circuit is stopped the MOSFET output. The switching output holds low level down to next pulse output at OCP operating.

When IN- pin voltage becomes 0.5V or less, it operates with 370kHz (typ.).

At the same time starts pulse counting, and stops the switching operation when the overcurrent detection continues approx 1ms.

After NJW4153 switching operation was stopped, it restarts by soft start function after the cool down time of approx 8ms (typ.).

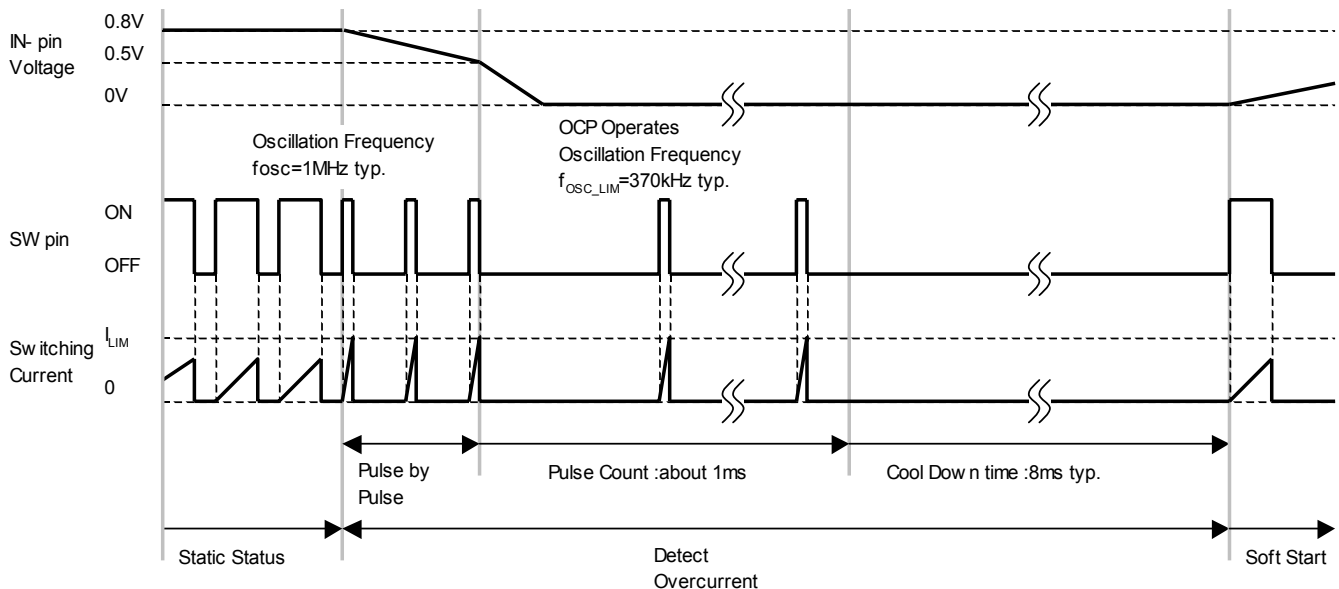

Fig. 2. Timing Chart at Over Current Detection

● Thermal Shutdown Function (TSD)

When Junction temperature of the NJW4153 exceeds the 165°C^* , internal thermal shutdown circuit function stops SW function. When junction temperature decreases to 150°C^* or less, SW operation returns with soft start operation.

The purpose of this function is to prevent malfunctioning of IC at the high junction temperature. Therefore it is not something that urges positive use. You should make sure to operate within the junction temperature range rated (150°C). (* Design value)

● ON/OFF Function

The NJW4153 stops the operating and becomes standby status when the ON/OFF pin becomes less than 0.5V.

The ON/OFF pin internally pulls down with $450\text{k}\Omega$, therefore the NJW4153 becomes standby mode when the ON/OFF pin is OPEN. You should connect this pin to V^+ when you do not use standby function.

■ Application Information

● Inductors

Because a large current flows to the inductor, you should select the inductor with the large current capacity not to saturate. Optimized inductor value is determined by the input voltage and output voltage.

The Optimized inductor value: (It is a reference value.)

$$V_{iIN}=12V \rightarrow V_{OUT}=5.0V \quad : L \leq 10\mu H$$

$$V_{iIN}=24V \rightarrow V_{OUT}=5.0V \quad : L \leq 10\mu H$$

You should set the inductor as a guide from above mentioned value to half value.

Reducing L decreases the size of the inductor. However a peak current increases and adversely affects the efficiency. (Fig. 3.)

Moreover, you should be aware that the output current is limited because it becomes easy to operating to the overcurrent limit.

The peak current is decided the following formula.

$$\Delta I_L = \frac{(V_{IN} - V_{OUT}) \times V_{OUT}}{L \times V_{IN} \times f_{OSC}} [A]$$

$$I_{pk} = I_{OUT} + \frac{\Delta I_L}{2} [A]$$

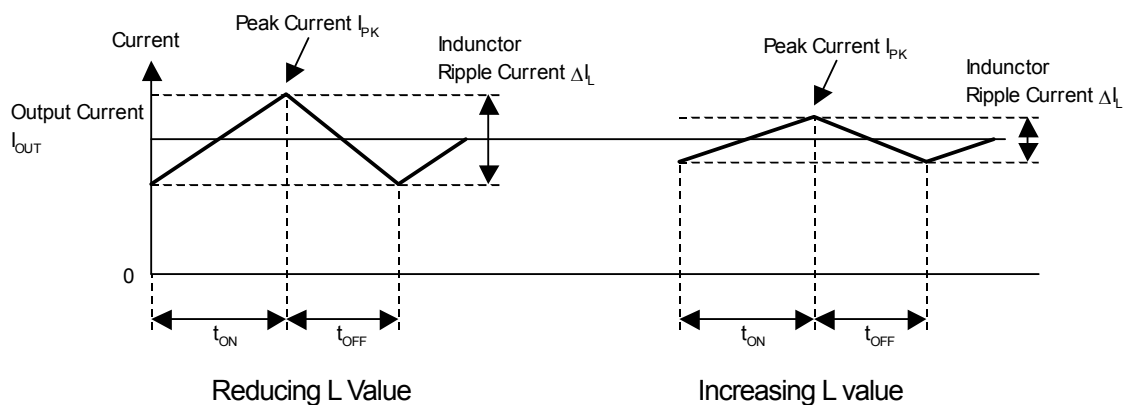

Fig. 3. Inductor Current State Transition (Continuous Conduction Mode)

■ Application Information (Continued)

● Catch Diode

When the switch element is in OFF cycle, power stored in the inductor flows via the catch diode to the output capacitor. Therefore during each cycle current flows to the diode in response to load current. Because diode's forward saturation voltage and current accumulation cause power loss, a Schottky Barrier Diode (SBD), which has a low forward saturation voltage, is ideal.

An SBD also has a short reverse recovery time. If the reverse recovery time is long, through current flows when the switching transistor transitions from OFF cycle to ON cycle. This current may lower efficiency and affect such factors as noise generation.

● Input Capacitor

Transient current flows into the input section of a switching regulator responsive to frequency. If the power supply impedance provided to the power supply circuit is large, it will not be possible to take advantage of the NJW4153 performance due to input voltage fluctuation. Therefore insert an input capacitor as close to the MOSFET as possible. A ceramic capacitor is the optimal for input capacitor.

The effective input current can be expressed by the following formula.

$$I_{\text{RMS}} = I_{\text{OUT}} \times \frac{\sqrt{V_{\text{OUT}} \times (V_{\text{IN}} - V_{\text{OUT}})}}{V_{\text{IN}}} \text{ [A]}$$

In the above formula, the maximum current is obtained when $V_{\text{IN}} = 2 \times V_{\text{OUT}}$, and the result in this case is

$$I_{\text{RMS}} = I_{\text{OUT(MAX)}} \div 2.$$

When selecting the input capacitor, carry out an evaluation based on the application, and use a capacitor that has adequate margin.

● Output Capacitor

An output capacitor stores power from the inductor, and stabilizes voltage provided to the output. Because NJW4153 corresponds to the output capacitor of low ESR, the ceramic capacitor is the optimal for compensation.

The Optimized capacitor value: (It is a reference value.)

$$V_{\text{OUT}} = 5.0\text{V} \quad : C_{\text{OUT}} > = 22\mu\text{F}$$

In addition, you should consider varied characteristics of capacitor (a frequency characteristic, a temperature characteristic, a DC bias characteristic and so on) and unevenness peculiar to a capacitor supplier enough.

Therefore when selecting a capacitors, you should confirm the characteristics with supplier datasheets.

When selecting an output capacitor, you must consider Equivalent Series Resistance (ESR) characteristics, ripple current, and breakdown voltage.

The output ripple noise can be expressed by the following formula.

$$V_{\text{ripple(p-p)}} = \text{ESR} \times \Delta I_{\text{L}} \text{ [V]}$$

The effective ripple current that flows in a capacitor (I_{rms}) is obtained by the following equation.

$$I_{\text{rms}} = \frac{\Delta I_{\text{L}}}{2\sqrt{3}} \text{ [Arms]}$$

■ Application Information (Continued)

● Setting Output Voltage, Compensation Capacitor

The output voltage V_{OUT} is determined by the relative resistances of R1, R2. The current that flows in R1, R2 must be a value that can ignore the bias current that flows in ER AMP.

$$V_{OUT} = \left(\frac{R2}{R1} + 1 \right) \times V_B \text{ [V]}$$

The zero points are formed with R2 and C_{FB} , and it makes for the phase compensation of NJW4153. The zero point is shown the following formula.

$$f_{z1} = \frac{1}{2 \times \pi \times R2 \times C_{FB}} \text{ [Hz]}$$

You should set the zero point as a guide from 30kHz to 50kHz.

■ Application Information (Continued)

● Board Layout

In the switching regulator application, because the current flow corresponds to the oscillation frequency, the substrate (PCB) layout becomes an important.

You should attempt the transition voltage decrease by making a current loop area minimize as much as possible. Therefore, you should make a current flowing line thick and short as much as possible. Fig.4. shows a current loop at step-down converter. Especially, should lay out high priority the loop of C_{IN} -SW-SBD that occurs rapid current change in the switching. It is effective in reducing noise spikes caused by parasitic inductance.

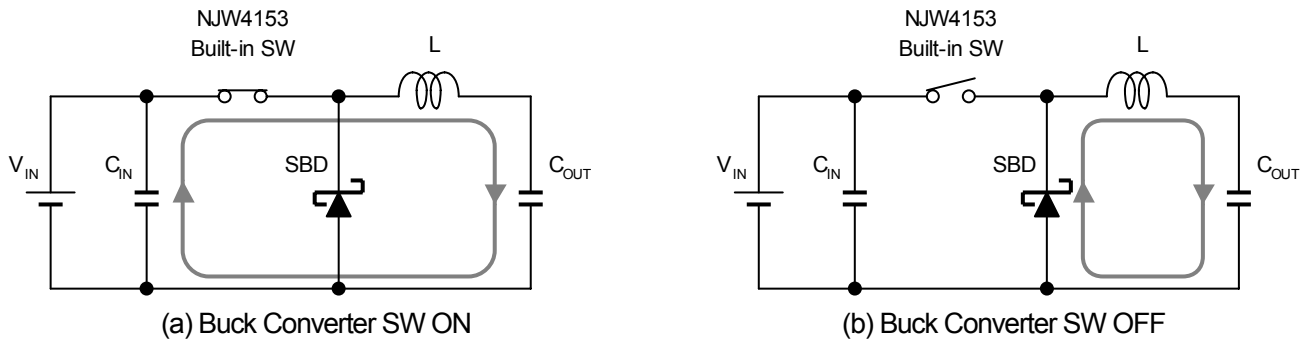

Fig. 4. Current Loop at Buck Converter

Concerning the GND line, it is preferred to separate the power system and the signal system, and use single ground point.

The voltage sensing feedback line should be as far away as possible from the inductance. Because this line has high impedance, it is laid out to avoid the influence noise caused by flux leaked from the inductance.

Fig. 5. shows example of wiring at buck converter. Fig. 6 shows the PCB layout example.

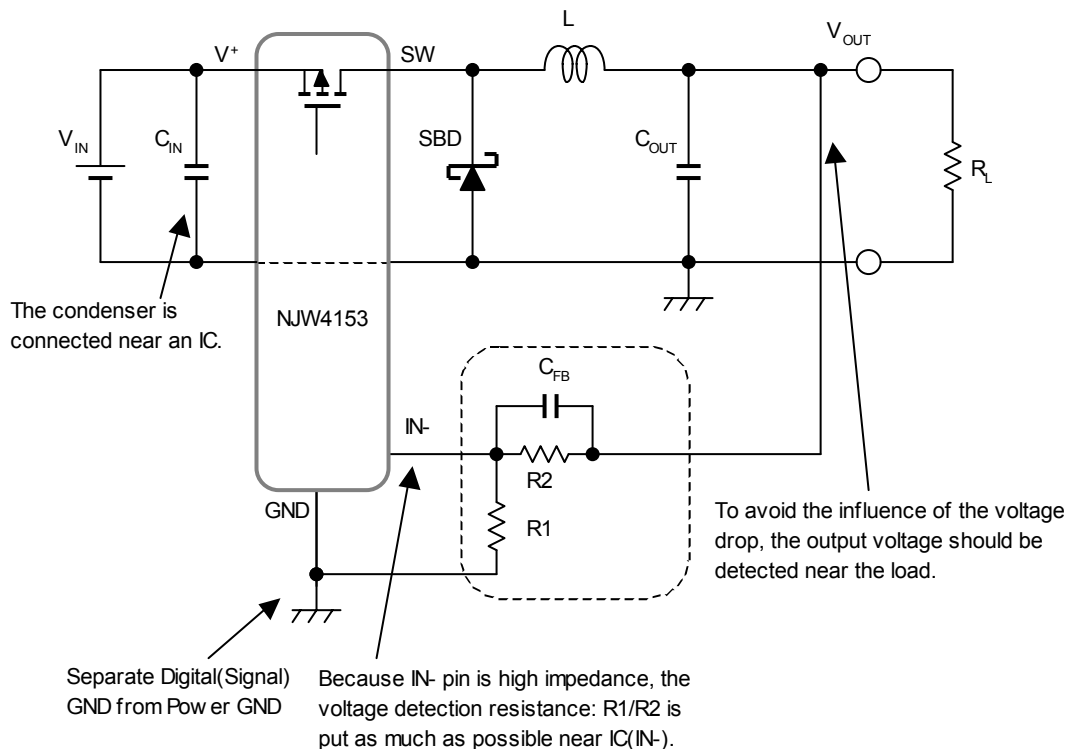
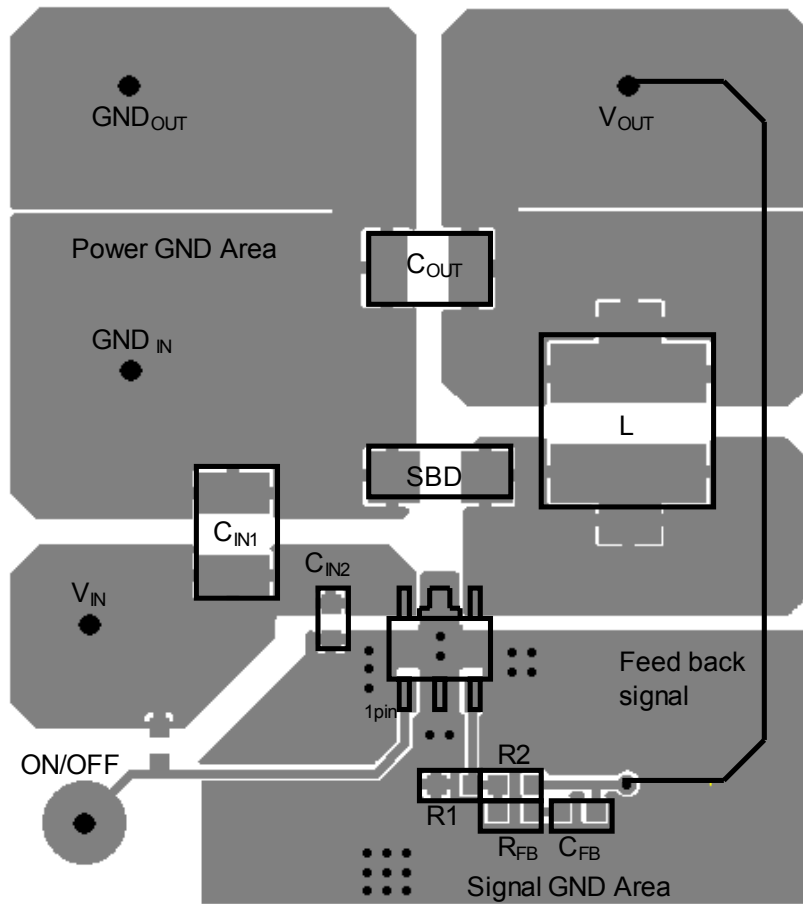

Fig. 5. Board Layout at Buck Converter

■ Application Information (Continued)



Connect Signal GND line and Power GND line on backside pattern

Fig. 6. Layout Example (upper view)

■ Calculation of Package Power

A lot of the power consumption of buck converter occurs from the internal switching element (Power MOSFET). Power consumption of NJW4153 is roughly estimated as follows.

$$\begin{aligned} \text{Input Power:} & P_{IN} = V_{IN} \times I_{IN} \quad [W] \\ \text{Output Power:} & P_{OUT} = V_{OUT} \times I_{OUT} \quad [W] \\ \text{Diode Loss:} & P_{DIODE} = V_F \times I_{L(avg)} \times \text{OFF duty} \quad [W] \\ \text{NJW4153 Power Consumption:} & P_{LOSS} = P_{IN} - P_{OUT} - P_{DIODE} \quad [W] \end{aligned}$$

Where:

V_{IN}	: Input Voltage for Converter	I_{IN}	: Input Current for Converter
V_{OUT}	: Output Voltage of Converter	I_{OUT}	: Output Current of Converter
V_F	: Diode's Forward Saturation Voltage	$I_{L(avg)}$: Inductor Average Current
OFF duty	: Switch OFF Duty		

Efficiency (η) is calculated as follows.

$$\eta = (P_{OUT} \div P_{IN}) \times 100 \quad [\%]$$

You should consider temperature derating to the calculated power consumption: P_D .

You should design power consumption in rated range referring to the power dissipation vs. ambient temperature characteristics (Fig. 7).

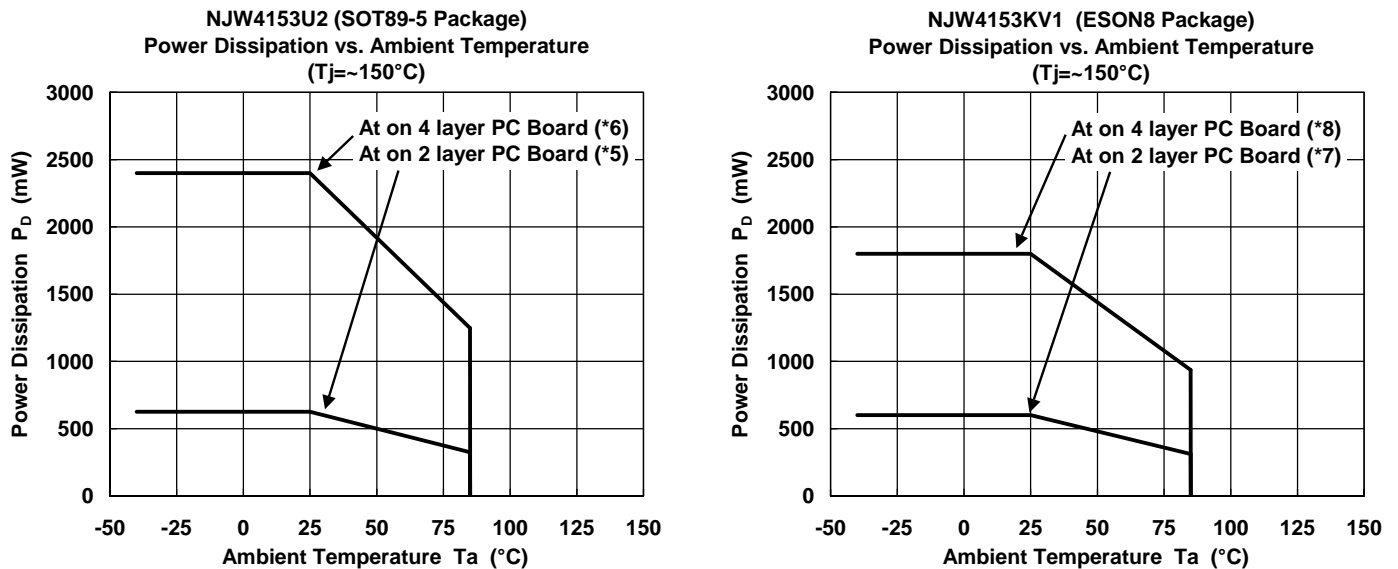

(*5): Mounted on glass epoxy board. (76.2×114.3×1.6mm: based on EIA/JEDEC standard size, 2Layers, Cu area 100mm²)

(*6): Mounted on glass epoxy board. (76.2×114.3×1.6mm: based on EIA/JEDEC standard, 4Layers)

(For 4Layers: Applying 74.2×74.2mm inner Cu area and a thermal via hole to a board based on JEDEC standard JESD51-5)

(*7): Mounted on glass epoxy board. (101.5×114.5×1.6mm: based on EIA/JEDEC standard, 2Layers FR-4, with Exposed Pad)

(*8): Mounted on glass epoxy board. (101.5×114.5×1.6mm: based on EIA/JEDEC standard, 4Layers FR-4, with Exposed Pad)

(For 4Layers: Applying 99.5×99.5mm inner Cu area and a thermal via hole to a board based on JEDEC standard JESD51-5)

Fig. 7. Power Dissipation vs. Ambient Temperature Characteristics

■ Application Design Examples

● Busk Converter Application Circuit

IC : NJW4153U2-A
 Input Voltage : $V_{IN}=12V, 24V$
 Output Voltage : $V_{OUT}=5V$
 Output Current : $I_{OUT}=1A$
 Oscillation frequency : $f_{osc}=1MHz$

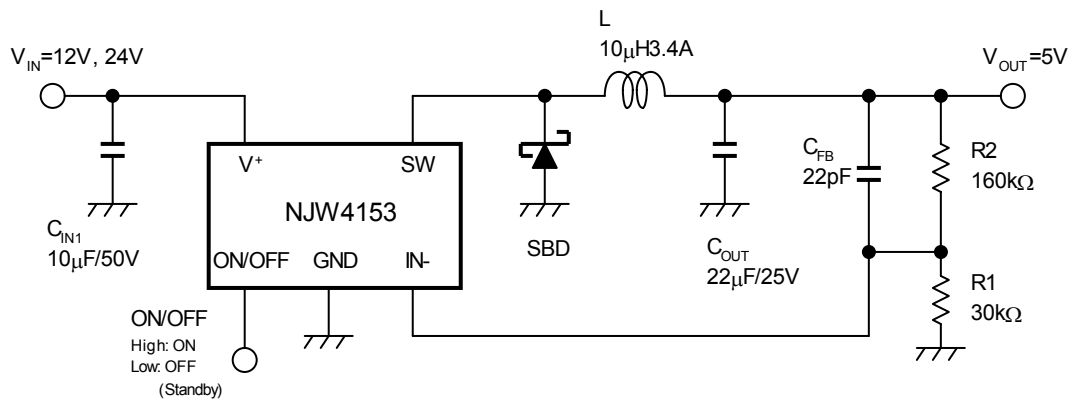

Reference	Qty.	Part Number	Description	Manufacturer
IC	1	NJW4153U2-A	Internal 1A MOSFET SW.REG. IC	New JRC
L	1	CDRH8D28HPNP-100N	Inductor 10µH, 3.4A(Ta=25°C) / 2.5A(Ta=100°C)	Sumida
SBD	1	CMS16	Schottky Diode 40V, 3A	Toshiba
C _{IN}	1	UMK325BJ106MM	Ceramic Capacitor 3225 10µF, 50V, X5R	Taiyo Yuden
C _{OUT}	1	GRM32EB31E226KE15	Ceramic Capacitor 3225 22µF, 25V, B	Murata
C _{FB}	1	22pF	Ceramic Capacitor 1608 22pF, 50V, CH	Std.
R1	1	30kΩ	Resistor 1608 30kΩ, ±1%, 0.1W	Std.
R2	1	160kΩ	Resistor 1608 160kΩ, ±1%, 0.1W	Std.

Application Characteristics :NJW4153U2-A

- At $V_{OUT}=5.0V$ setting ($R1=30k\Omega$, $R2=160k\Omega$)

Efficiency vs. Output Current
(A ver., $V_{OUT}=5V$, $T_a=25^\circ C$)

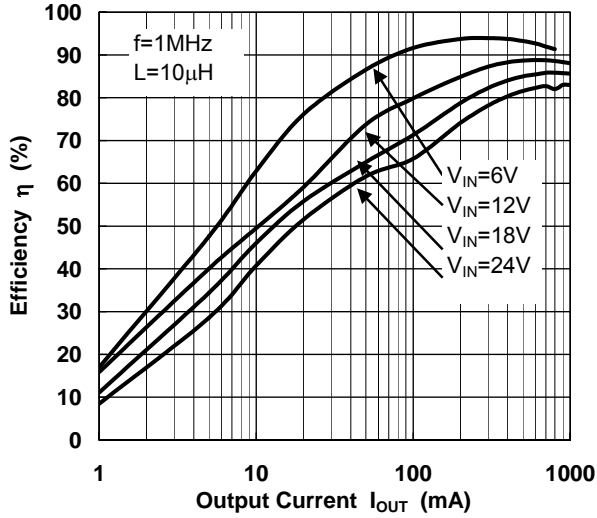

Output Voltage vs. Output Current
(A ver., $T_a=25^\circ C$)

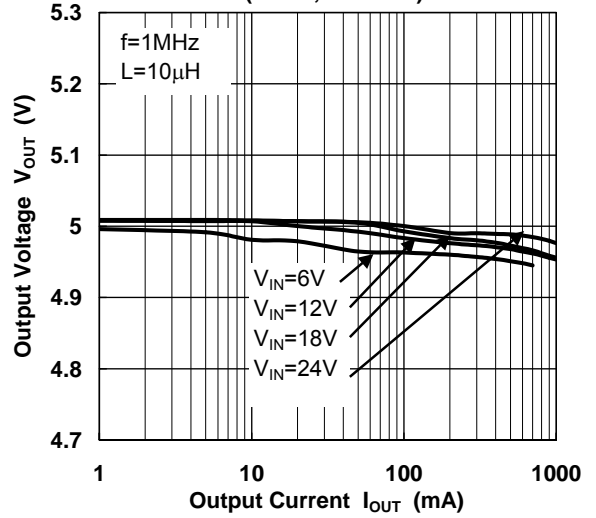

- At $V_{OUT}=3.3V$ setting ($R1=47k\Omega$, $R2=150k\Omega$)

Efficiency vs. Output Current
(A ver., $V_{OUT}=3.3V$, $T_a=25^\circ C$)

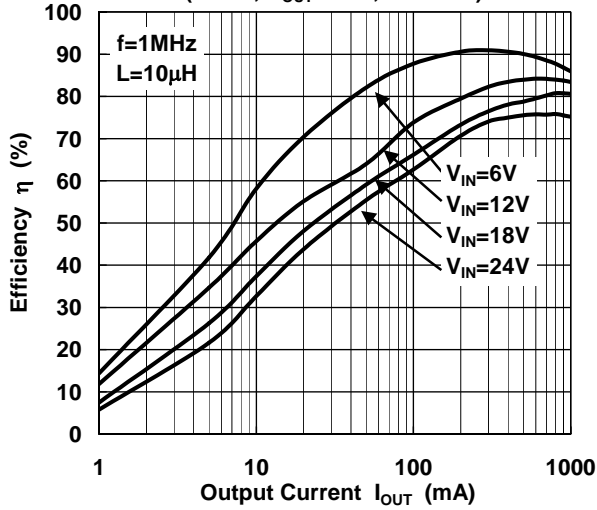

Output Voltage vs. Output Current
(A ver., $T_a=25^\circ C$)

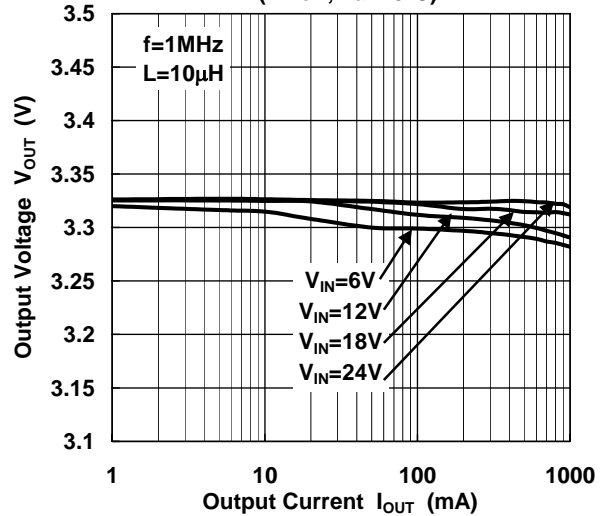

Technical Information

■ Inverting Converter Application Circuit

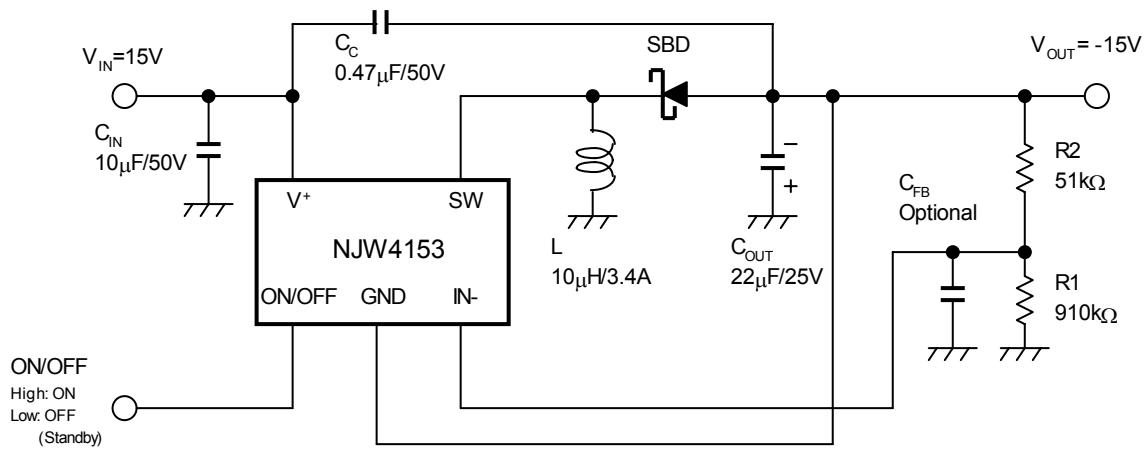

Reference	Qty.	Part Number	Description	Manufacturer
IC	1	NJW4153U2-A	Internal 1A MOSFET SW.REG. IC	New JRC
L	1	CDRH8D28HPNP-100N	Inductor 10µH, 3.4A(Ta=25°C) / 2.5A(Ta=100°C)	Sumida
SBD	1	CMS16	Schottky Diode 40V, 3A	Toshiba
C _{IN}	1	UMK325BJ106MM	Ceramic Capacitor 3225 10µF, 50V, X5R	Taiyo Yuden
C _{OUT}	1	GRM32EB31E226KE15	Ceramic Capacitor 3225 22µF, 25V, B	Murata
C _C	1	GRM21BB31H474KA87	Ceramic Capacitor 2012 0.47µF, 50V, B	Murata
C _{FB}	0	— (Optional)	Optional	—
R1	1	910kΩ	Resistor 1608 910kΩ, ±1%, 0.1W	Std.
R2	1	51kΩ	Resistor 1608 51kΩ, ±1%, 0.1W	Std.

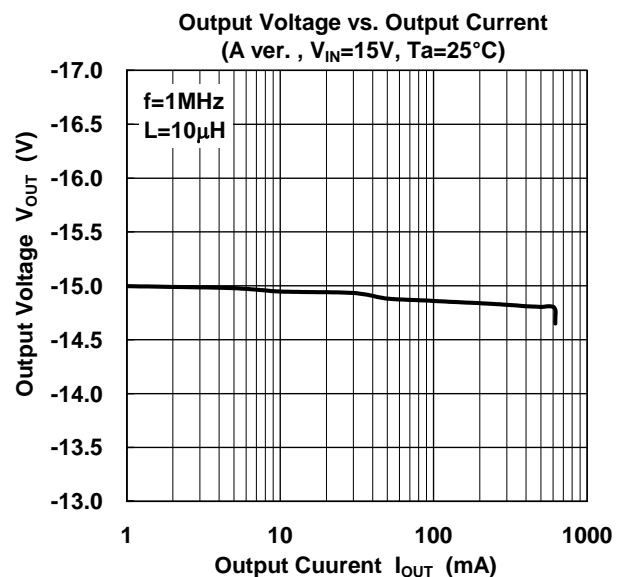
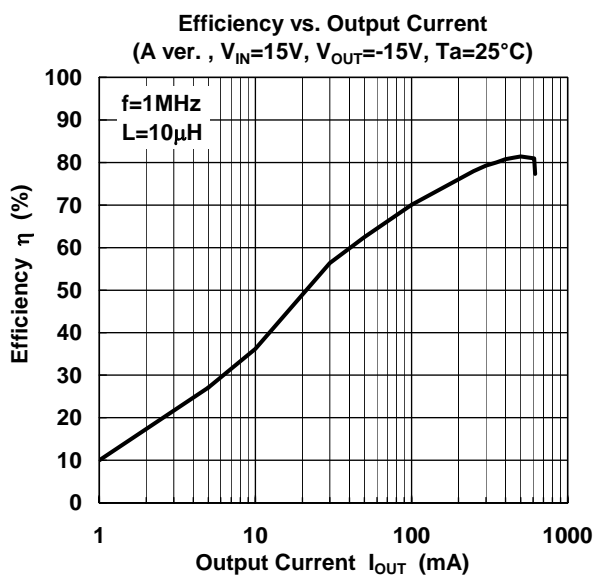

MEMO

[CAUTION]

The specifications on this databook are only given for information, without any guarantee as regards either mistakes or omissions. The application circuits in this databook are described only to show representative usages of the product and not intended for the guarantee or permission of any right including the industrial rights.

Mouser Electronics

Authorized Distributor

Click to View Pricing, Inventory, Delivery & Lifecycle Information:

[NJR:](#)

[NJW4153U2-A-TE2](#)