

THIS DRAWING IS UNPUBLISHED. RELEASED FOR PUBLICATION
 © COPYRIGHT copyright.d8te- ALL RIGHTS RESERVED.

REVISIONS				
P	LTR	DESCRIPTION	DATE	APVD
1		PROPOSED	10JAN2018	CD MM
2		UPDATED	31JAN2018	CD EH
3		REVISED PER ECR-18-017862	22NOV2018	SR DD

- 1. MATERIAL:
-POLYCARBONATE COLOR: SEE TABLE
- 2. MUST COMPLY WITH DIRECTIVE 2002/95/EC (ROHS)
- 3. THIS PRODUCT HAS NOT COMPLETED VALIDATION TESTING
- 4. MODULE BASE TE P/N: 2213837-1

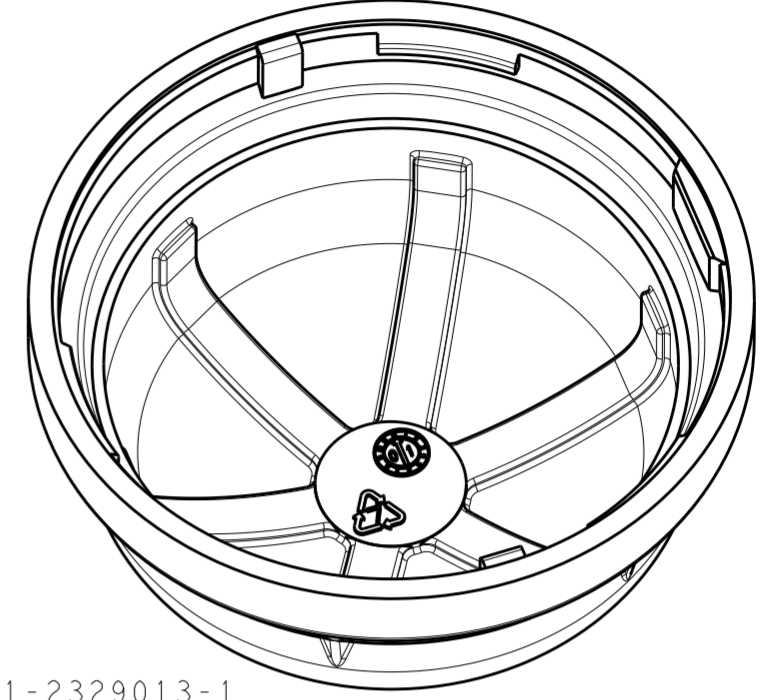
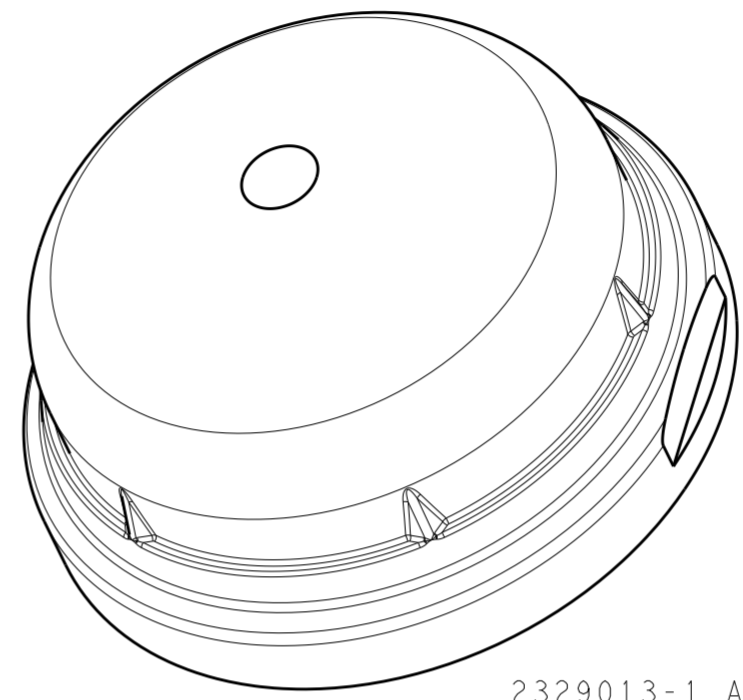
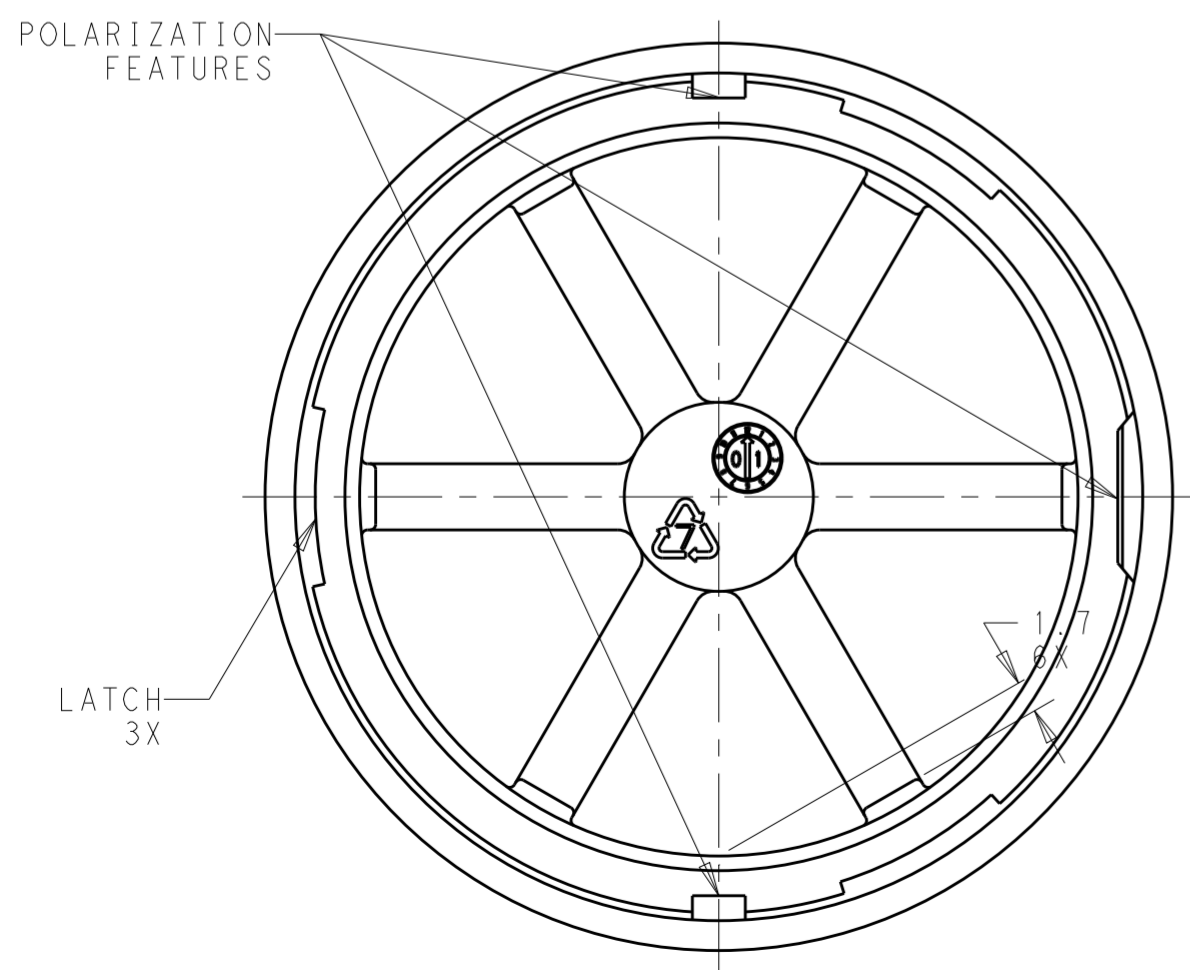
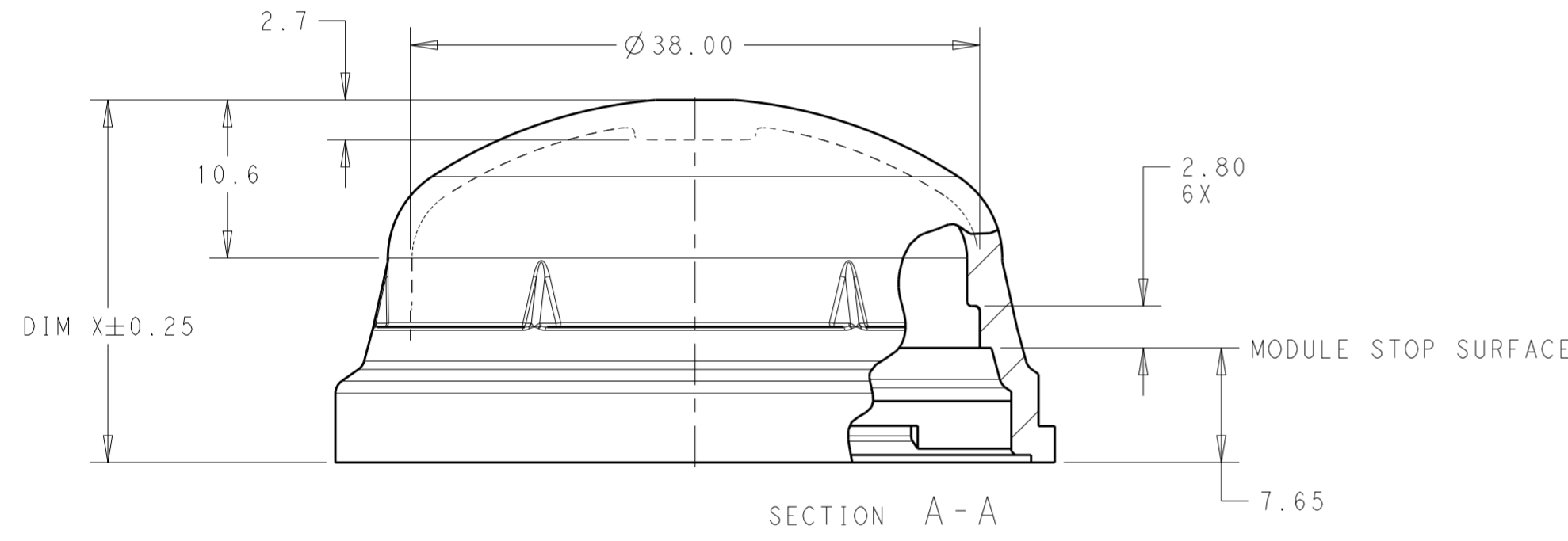
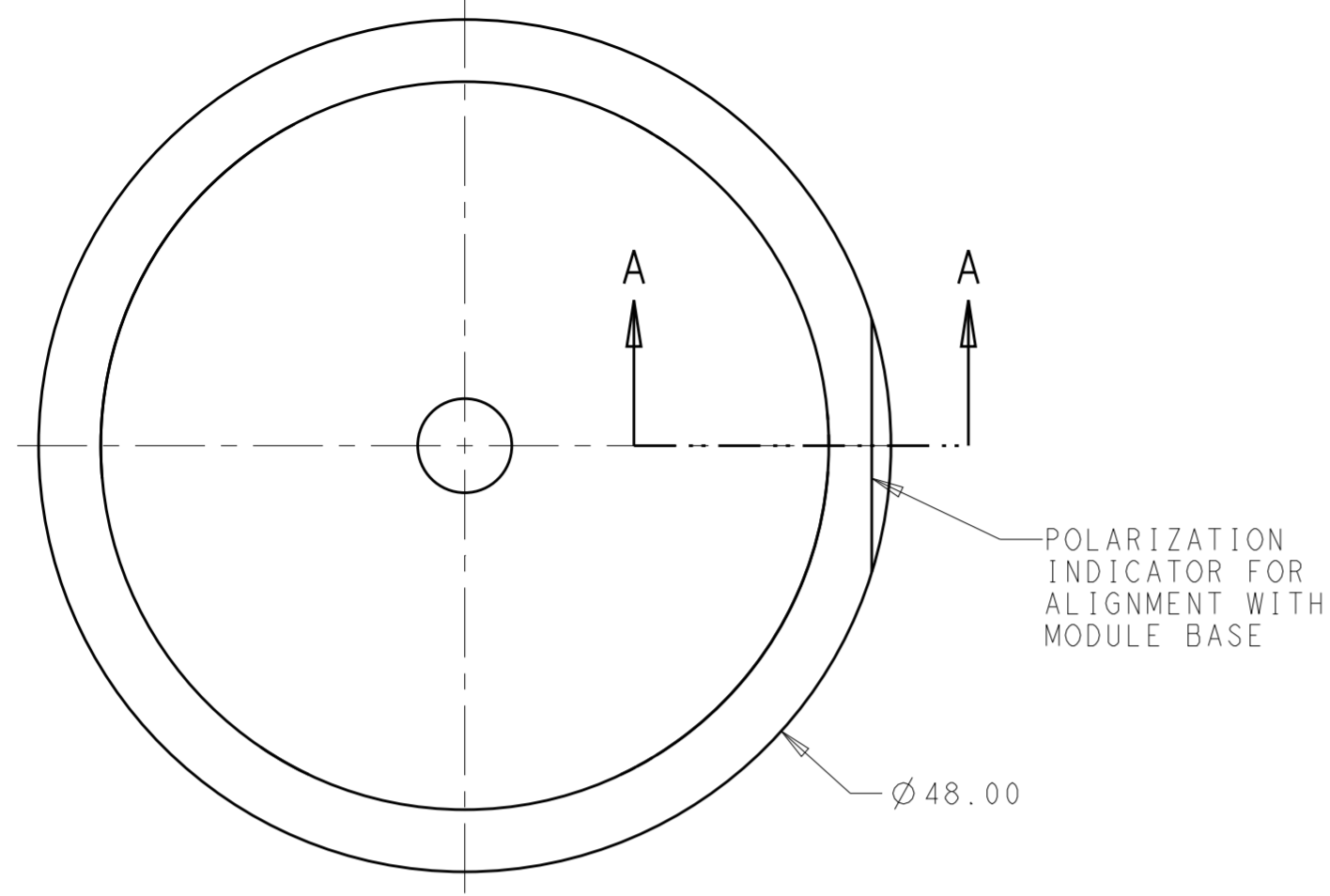

2329013-1 AND 1-2329013-1
SHOWN
SCALE 2:1

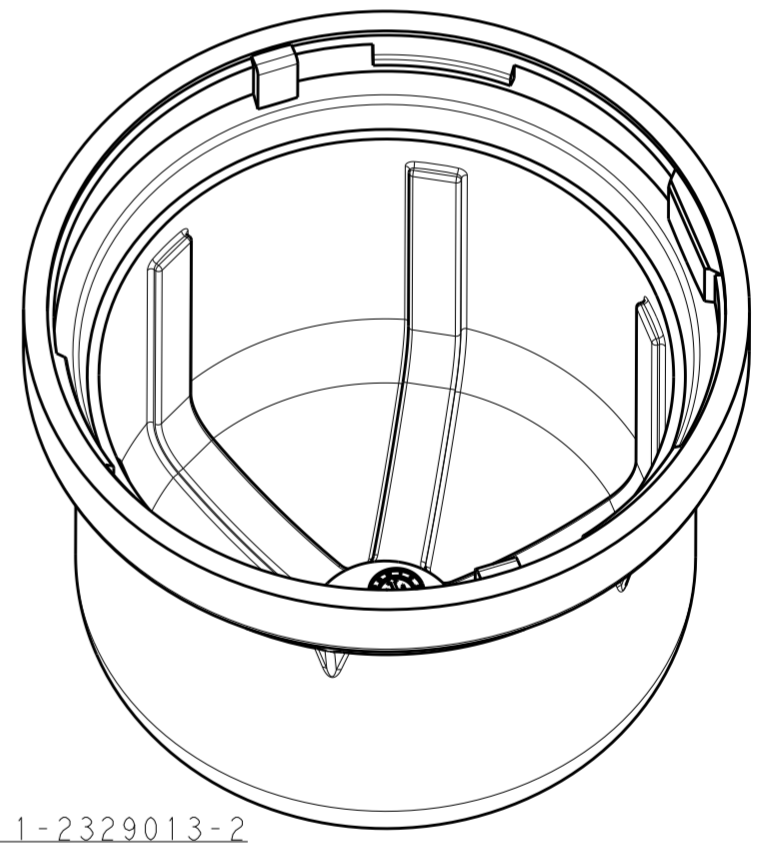
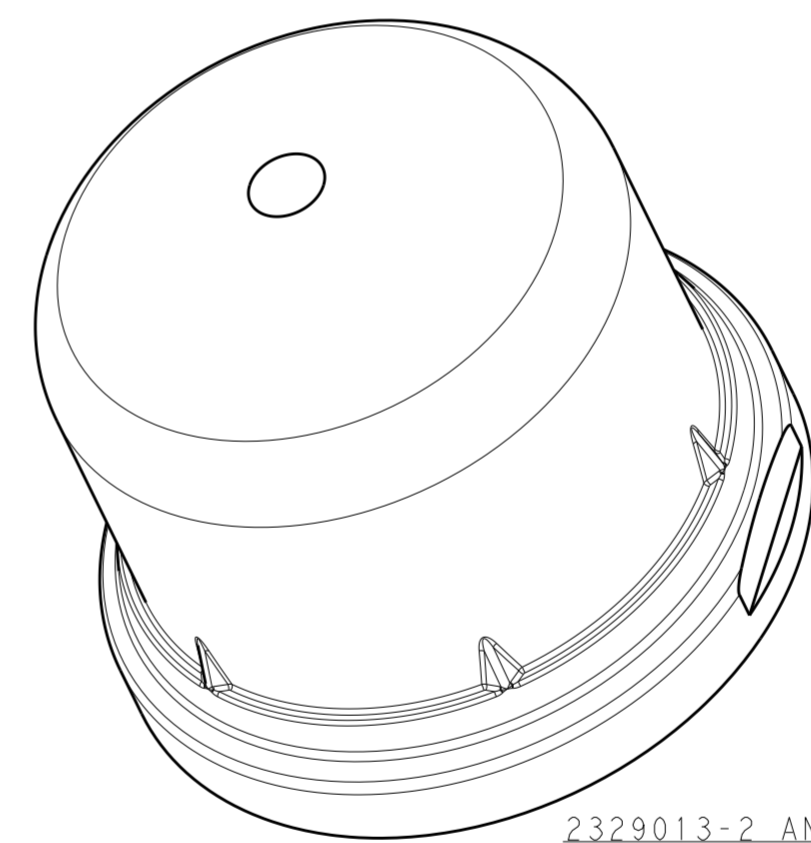

2329013-2 AND 1-2329013-2
SHOWN
SCALE 2:1

APPROX. LIGHT TRANSMISSION	COLOR	DIM X	PART NO.
78	TRANSPARENT CLEAR	39.25	1-2329013-2
78	TRANSPARENT CLEAR	24.25	1-2329013-1
24	TRANSPARENT SMOKE	39.25	2329013-2
24	TRANSPARENT SMOKE	24.25	2329013-1

THIS DRAWING IS A CONTROLLED DOCUMENT.		DWN C. DAILY 10JAN2018	STE TE Connectivity	
		CHK M. STOLLER 10JAN2018		
DIMENSIONS: mm		TOLERANCES UNLESS OTHERWISE SPECIFIED:		NAME DOME, LUMAWISE ENDURANCE S, 40mm
0 PLC ±		1 PLC ±0.2		PRODUCT SPEC 108-133073
2 PLC ±0.10		3 PLC ±		APPLICATION SPEC 114-133074
4 PLC ±		ANGLES ±1°		SIZE A200779
MATERIAL SEE TABLE		FINISH		CAGE CODE C-2329013
		CUSTOMER DRAWING		RESTRICTED TO -
		SCALE 5:2		SHEET 1 OF 1
				REV A