

MODEL NO.	PACKAGING
134-1000-007	ONE PCS PER BAG

REV	ECO	DATE
001	ECO-17-0032	11/28/2017
002	ECO-18-0020	08/21/2018

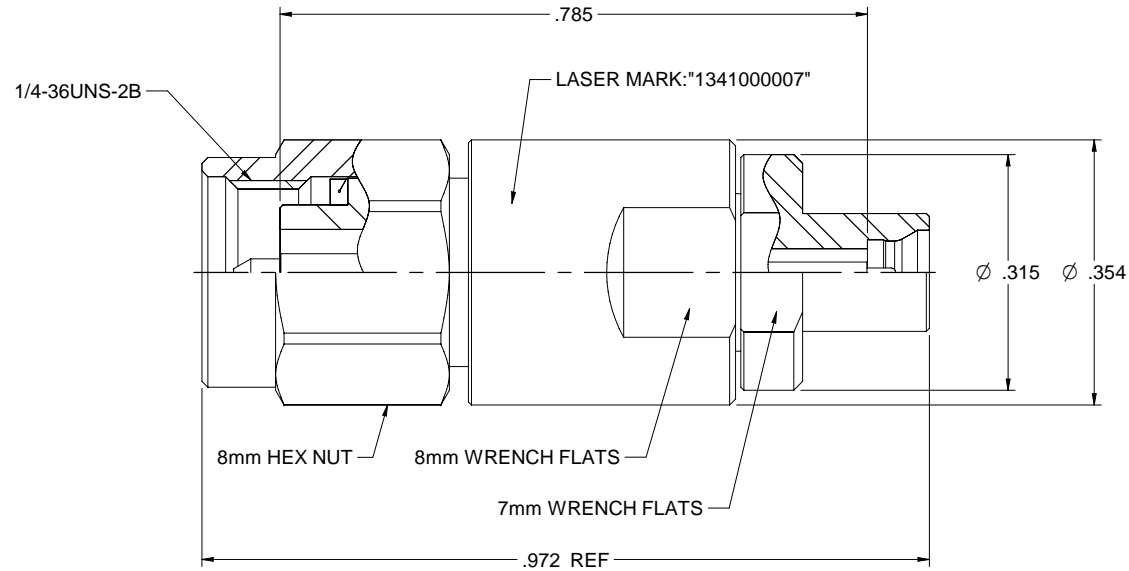

NOTES: UNLESS OTHERWISE SPECIFIED

1. MATERIAL & FINISH:

- 1.1 BODY, CONTACT BODY & SHELL: PASSIVATED STAINLESS STEEL
- 1.2 CONTACT PIN: GOLD PLATED BERYLLIUM COPPER
- 1.3 INSULATOR1: ULTEM1000 AMBER
- 1.4 INSULATOR2: PTFE WHITE
- 1.5 C RING: BERYLLIUM COPPER
- 1.6 GASKET: SILICONE RED

2. ELECTRICAL:

- 2.1 IMPEDANCE: 50 OHMS
- 2.2 FREQUENCY RANGE: DC-40 GHz
- 2.3 VOLTAGE STANDING WAVE RATIO: 1.3MAX
- 2.4 DIELECTRIC WITHSTANDING VOLTAGE: 325 VRMS MIN
- 2.5 CONTACT RESISTANCE:
 - 2.5.1 CENTER CONTACT: 6 MILLIOHM MAX
 - 2.5.2 OUTER CONTACT: 2 MILLIOHM MAX
- 2.6 INSULATOR RESISTANCE: 5000 MEGOHM MIN

3. MECHANICAL:

- 3.1 ENGAGEMENT FORCE: 0.23NM MAX (2.92MM), FULL DETENT 19 N MAX (SMPM)
- 3.2 DISENGAGEMENT FORCE: 0.23NM MAX (2.92MM), FULL DETENT 29 N MAX (SMPM)
- 3.3 COUPLING PROOF TORQUE: 1.7 NM MIN.
- 3.4 COUPLING NUT RETENTION: 267 N MIN
- 3.5 CONTACT RETENTION: 22 N MIN
- 3.6 DURABILITY: 500 CYCLES MIN (2.92MM), FULL DETENT 100 CYCLES MIN (SMPM)

4. ENVIRONMENT:

- 4.1 THERMAL SHOCK: MIL-STD-202, METHOD 107, CONDITION B.
- 4.2 OPERATING TEMPERATURE: -65 TO 165°C
- 4.3 SHOCK: MIL-STD-202, METHOD 213, CONDITION I
- 4.4 VIBRATION: MIL-STD-202, METHOD 204, CONDITION D
- 4.5 MOISTURE RESISTANCE: MIL-STD-202, METHOD 106

	Model No. 134-1000-007	Johnson	
		TITLE: ADAPTER ASSEMBLY, 2.92mm(SMK) PLUG TO SMPM PLUG	
	DATE: 08/21/2018 DRAWN BY: Betty Yu	DRAWING NO: 134-1000-007	REV: 002
XXXX - 02 XXXX - 01 ANGLES: 45°	DO NOT SCALE DRAWING	NONE	Sheet 1 of 1