

FEATURES

- V_{CC} Operation at 3 V and 4.3 V
- 1.8-V Compatible Control-Pin Inputs
- I_{OFF} Supports Partial Power-Down Mode Operation
- $r_{on} = 10 \Omega$ Maximum
- $\Delta r_{on} < 0.35 \Omega$ Typical
- $C_{io(ON)} = 6 \text{ pF}$ Typical
- Low Power Consumption (1 μA Maximum)
- ESD Performance Tested Per JESD 22
 - 6000-V Human-Body Model (A114-B, Class II)
 - 1000-V Charged-Device Model (C101)
 - 250-V Machine Model (A115-A)
- Wide –3-dB Bandwidth = 1220 MHz Typical
- Packaged in 8-Pin TQFN (1.5 mm \times 1.5 mm)

APPLICATIONS

- Routes Signals for USB 1.0, 1.1, and 2.0

DESCRIPTION/ORDERING INFORMATION

The TS3USB31 is a high-bandwidth switch specially designed for the switching of high-speed USB 2.0 signals in handset and consumer applications, such as cell phones, digital cameras, and notebooks with hubs or controllers with limited USB I/Os. The wide bandwidth (750 MHz) of this switch allows signals to pass with minimum edge and phase distortion. The switch is bidirectional and offers little or no attenuation of the high-speed signals at the outputs. It is designed for low bit-to-bit skew and high channel-to-channel noise isolation, and is compatible with various standards, such as high-speed USB 2.0 (480 Mbps).

ORDERING INFORMATION

T_A	PACKAGE ⁽¹⁾⁽²⁾		ORDERABLE PART NUMBER	TOP-SIDE MARKING
–40°C to 85°C	QFN – RSE	Tape and reel	TS3USB31RSER	L9

(1) Package drawings, thermal data, and symbolization are available at www.ti.com/packaging.

(2) For the most current package and ordering information, see the Package Option Addendum at the end of this document, or see the TI website at www.ti.com.

PIN DESCRIPTION

NAME	DESCRIPTION
\overline{OE}	Bus-switch enable
D+, D–, HSD+, HSD–	Data ports
NC	No connect

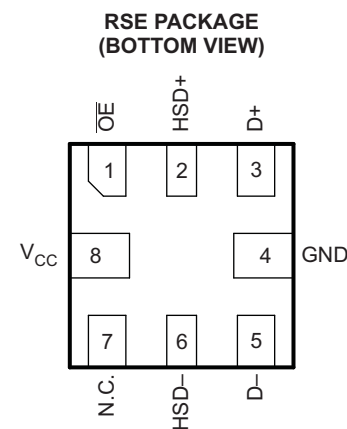
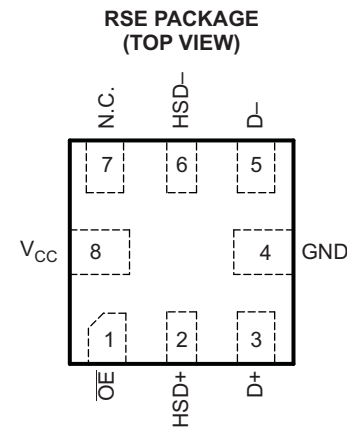

N.C. – No internal connection



Please be aware that an important notice concerning availability, standard warranty, and use in critical applications of Texas Instruments semiconductor products and disclaimers thereto appears at the end of this data sheet.

TS3USB31 HIGH-SPEED USB 2.0 (480-Mbps) 1-PORT SWITCH WITH SINGLE ENABLE

SCDS242D–JULY 2007–REVISED JANUARY 2008

TRUTH TABLE

$\overline{\text{OE}}$	FUNCTION
H	Disconnect
L	D+, D– = HSD+, HSD–

BLOCK DIAGRAM

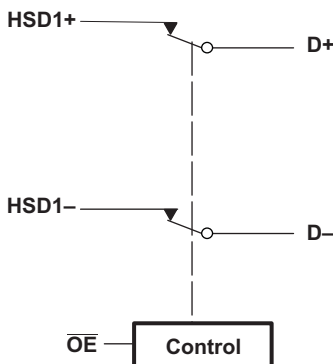

ABSOLUTE MAXIMUM RATINGS⁽¹⁾

over operating free-air temperature range (unless otherwise noted)

		MIN	MAX	UNIT	
V_{CC}	Supply voltage range	–0.5	7	V	
V_{IN}	Control input voltage range ⁽²⁾⁽³⁾	–0.5	7	V	
$V_{I/O}$	Switch I/O voltage range ⁽²⁾⁽³⁾⁽⁴⁾	HSD+, HSD–	–0.5	$V_{CC} + 0.3$	V
		D+, D– when $V_{CC} > 0$	–0.5	$V_{CC} + 0.3$	
		D+, D– when $V_{CC} = 0$		5.25	
I_{IK}	Control input clamp current	$V_{IN} < 0$	–50	mA	
$I_{I/OK}$	I/O port clamp current	$V_{I/O} < 0$	–50	mA	
$I_{I/O}$	ON-state switch current ⁽⁵⁾		±64	mA	
	Continuous current through V_{CC} or GND		±100	mA	
T_{stg}	Storage temperature range	–65	150	°C	

- Stresses beyond those listed under "absolute maximum ratings" may cause permanent damage to the device. These are stress ratings only, and functional operation of the device at these or any other conditions beyond those indicated under "recommended operating conditions" is not implied. Exposure to absolute-maximum-rated conditions for extended periods may affect device reliability.
- All voltages are with respect to ground, unless otherwise specified.
- The input and output voltage ratings may be exceeded if the input and output clamp-current ratings are observed.
- V_I and V_O are used to denote specific conditions for $V_{I/O}$.
- I_I and I_O are used to denote specific conditions for $I_{I/O}$.

PACKAGE THERMAL IMPEDANCE

		TYP	UNIT
θ_{JA}	Package thermal impedance ⁽¹⁾	253	°C/W

- The package thermal impedance is calculated in accordance with JESD 51-7.

RECOMMENDED OPERATING CONDITIONS⁽¹⁾

		MIN	MAX	UNIT
V _{CC}	Supply voltage	3.0	4.3	V
V _{IH}	High-level control input voltage	V _{CC} = 3 V to 3.6 V	1.3	V
		V _{CC} = 4.3 V	1.7	
V _{IL}	Low-level control input voltage	V _{CC} = 3 V to 3.6 V	0.5	V
		V _{CC} = 4.3 V	0.7	
V _{I/O}	Data input/output voltage	0	V _{CC}	V
T _A	Operating free-air temperature	–40	85	°C

(1) All unused control inputs of the device must be held at V_{CC} or GND to ensure proper device operation. Refer to the TI application report, *Implications of Slow or Floating CMOS Inputs*, literature number SCBA004.

ELECTRICAL CHARACTERISTICS⁽¹⁾

over operating free-air temperature range (unless otherwise noted)

PARAMETER		TEST CONDITIONS	MIN	TYP ⁽²⁾	MAX	UNIT
V _{IK}		V _{CC} = 3 V, I _I = –18 mA			–1.2	V
I _{IN}	Control inputs	V _{CC} = 4.3 V, V _{IN} = 0 to 4.3 V, V _{CC} = 0 V			±1	μA
I _{OZ} ⁽³⁾		V _{CC} = 4.3 V, V _O = 0 to 3.6 V, V _I = 0, Switch OFF			±1	μA
I _{OFF}	D+ and D–	V _{CC} = 0 V, V _O = 0 to 4.3 V, V _I = 0, V _{IN} = V _{CC} or GND			±2	μA
I _{CC}		V _{CC} = 4.3 V, I _{I/O} = 0, Switch ON or OFF			1	μA
ΔI _{CC} ⁽⁴⁾	Control inputs	V _{CC} = 4.3 V, V _{IN} = 2.6 V			10	μA
C _{in}	Control inputs	V _{CC} = 0 V, V _{IN} = V _{CC} or GND		1		pF
C _{io(OFF)}		V _{CC} = 3.3 V, V _{I/O} = 3.3 V or 0, Switch OFF		2		pF
C _{io(ON)}		V _{CC} = 3.3 V, V _{I/O} = 3.3 V or 0, Switch ON		6		pF
r _{on} ⁽⁵⁾		V _{CC} = 3 V, V _I = 0.4 V, I _O = –8 mA		6	10	Ω
Δr _{on}		V _{CC} = 3 V, V _I = 0.4 V, I _O = –8 mA		0.35		Ω
r _{on(flat)}		V _{CC} = 3 V, V _I = 0 V or 1 V, I _O = –8 mA		2		Ω

(1) V_{IN} and I_{IN} refer to control inputs. V_I, V_O, I_I, and I_O refer to data pins.

(2) All typical values are at V_{CC} = 3.3 V (unless otherwise noted), T_A = 25°C.

(3) For I/O ports, the parameter I_{OZ} includes the input leakage current.

(4) This is the increase in supply current for each input that is at the specified TTL voltage level, rather than V_{CC} or GND.

(5) Measured by the voltage drop between the A and B terminals at the indicated current through the switch. ON-state resistance is determined by the lower of the voltages of the two (A or B) terminals.

DYNAMIC ELECTRICAL CHARACTERISTICS

over operating range, T_A = –40°C to 85°C, V_{CC} = 3.3 V ± 10%, GND = 0 V

PARAMETER		TEST CONDITIONS	TYP ⁽¹⁾	UNIT
X _{TALK}	Crosstalk	R _L = 50 Ω, f = 240 MHz, See Figure 9	–53	dB
O _{IRR}	OFF isolation	R _L = 50 Ω, f = 240 MHz, See Figure 8	–30	dB
BW	Bandwidth (–3 dB)	R _L = 50 Ω, C _L = 5 pF, See Figure 10	1220	MHz

(1) For Max or Min conditions, use the appropriate value specified under Electrical Characteristics for the applicable device type.

TS3USB31 HIGH-SPEED USB 2.0 (480-Mbps) 1-PORT SWITCH WITH SINGLE ENABLE

SCDS242D–JULY 2007–REVISED JANUARY 2008

SWITCHING CHARACTERISTICS

over operating range, $T_A = -40^\circ\text{C}$ to 85°C , $V_{CC} = 3.3\text{ V} \pm 10\%$, $\text{GND} = 0\text{ V}$

PARAMETER		TEST CONDITIONS	MIN	TYP ⁽¹⁾	MAX	UNIT
t_{pd}	Propagation delay ⁽²⁾⁽³⁾	$R_L = 50\ \Omega$, $C_L = 5\ \text{pF}$, See Figure 11		0.25		ns
t_{ON}	Line enable time, $\overline{\text{OE}}$ to D, nD	$R_L = 50\ \Omega$, $C_L = 5\ \text{pF}$, See Figure 7			30	ns
t_{OFF}	Line disable time, $\overline{\text{OE}}$ to D, nD	$R_L = 50\ \Omega$, $C_L = 5\ \text{pF}$, See Figure 7			25	ns
$t_{SK(O)}$	Output skew between center port to any other port ⁽²⁾	$R_L = 50\ \Omega$, $C_L = 5\ \text{pF}$, See Figure 12		50		ps
$t_{SK(P)}$	Skew between opposite transitions of the same output ($t_{PHL} - t_{PLH}$) ⁽²⁾	$R_L = 50\ \Omega$, $C_L = 5\ \text{pF}$, See Figure 12		20		ps
t_J	Total jitter ⁽²⁾	$R_L = 50\ \Omega$, $C_L = 5\ \text{pF}$, $t_R = t_F = 500\ \text{ps}$ at 480 Mbps (PRBS = $2^{15} - 1$)		200		ps

(1) For Max or Min conditions, use the appropriate value specified under Electrical Characteristics for the applicable device type.

(2) Specified by design

(3) The bus switch contributes no propagational delay other than the RC delay of the on resistance of the switch and the load capacitance. The time constant for the switch alone is of the order of 0.25 ns for 10-pF load. Since this time constant is much smaller than the rise/fall times of typical driving signals, it adds very little propagational delay to the system. Propagational delay of the bus switch, when used in a system, is determined by the driving circuit on the driving side of the switch and its interactions with the load on the driven side.

APPLICATION INFORMATION

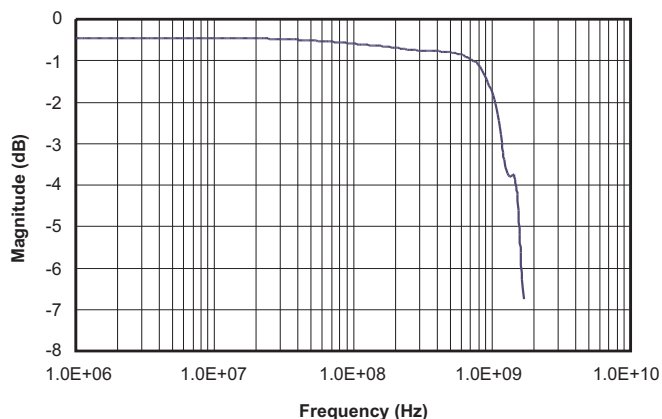

Figure 1. Insertion Loss

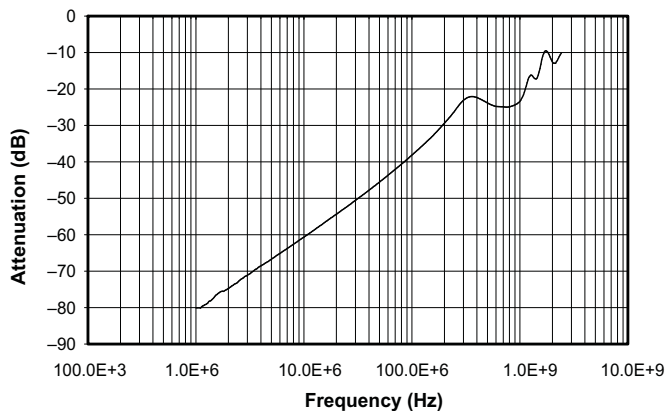

Figure 2. OFF Isolation

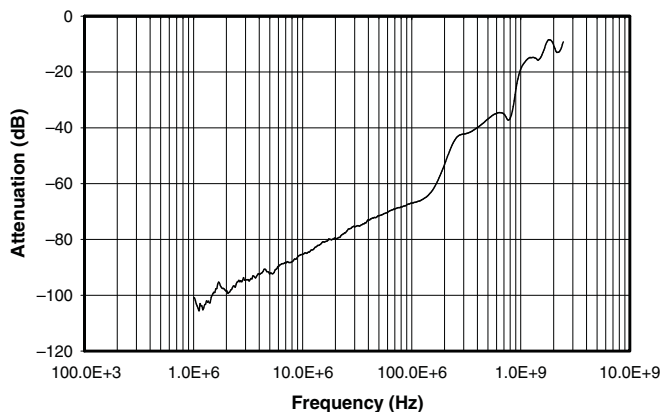

Figure 3. Crosstalk

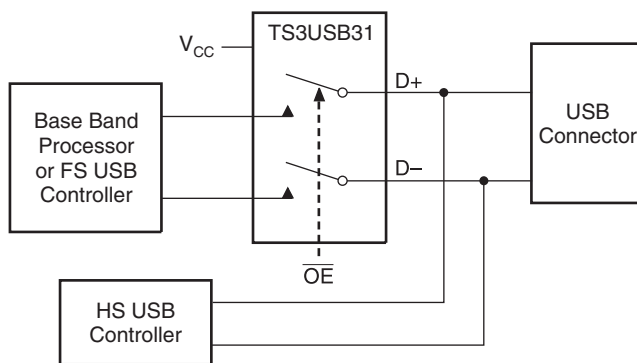

Figure 4. Application Diagram

TS3USB31 HIGH-SPEED USB 2.0 (480-Mbps) 1-PORT SWITCH WITH SINGLE ENABLE

SCDS242D—JULY 2007—REVISED JANUARY 2008

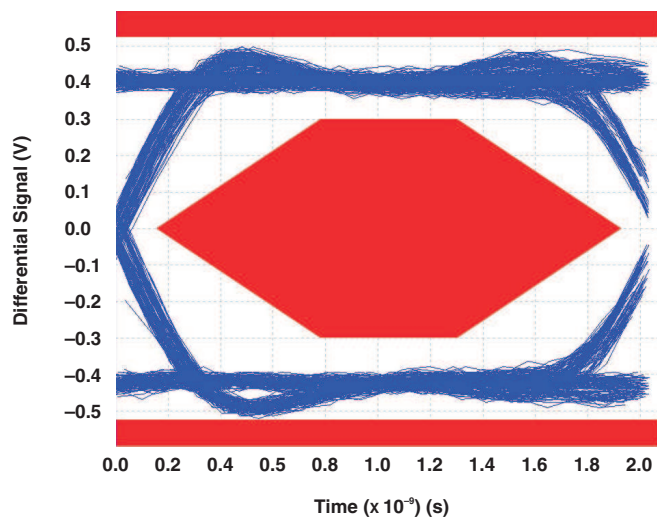

Figure 5. Eye Pattern: 480-Mbps USB Signal With No Switch (Through Path)

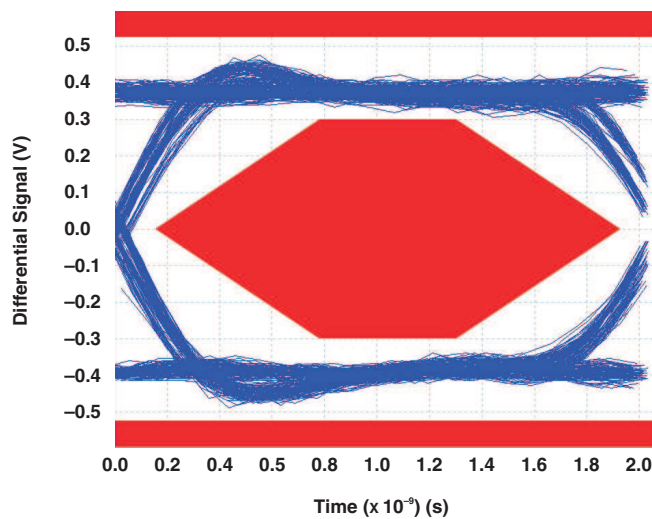

Figure 6. Eye Pattern: 480-Mbps USB Signal With Switch NO Path

PARAMETER MEASUREMENT INFORMATION

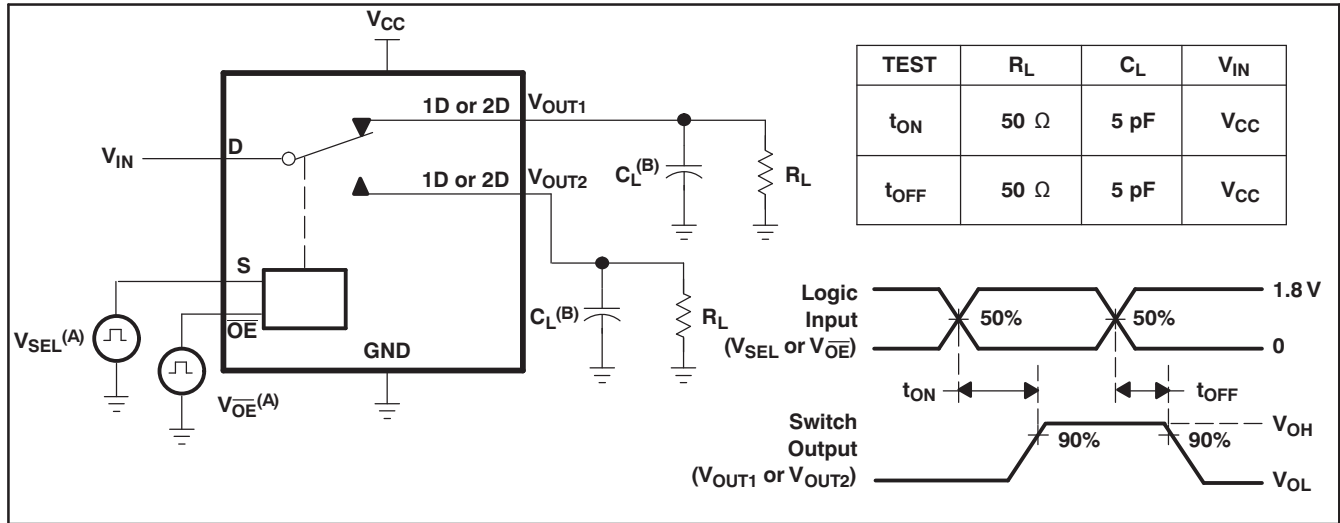

Figure 7. Turn-On (t_{ON}) and Turn-Off Time (t_{OFF})

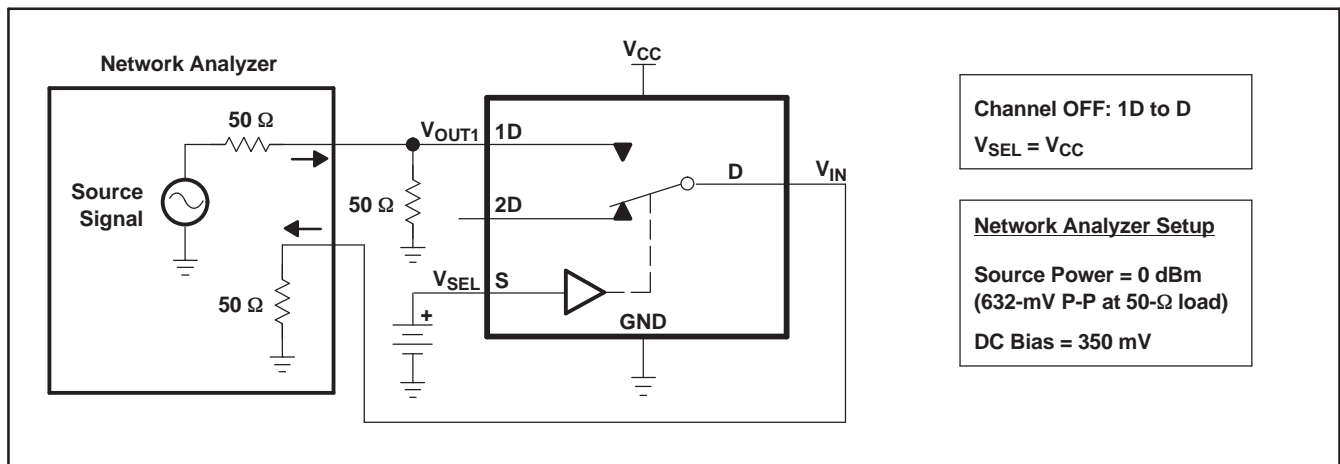

Figure 8. OFF Isolation (O_{IRR})

PARAMETER MEASUREMENT INFORMATION (continued)

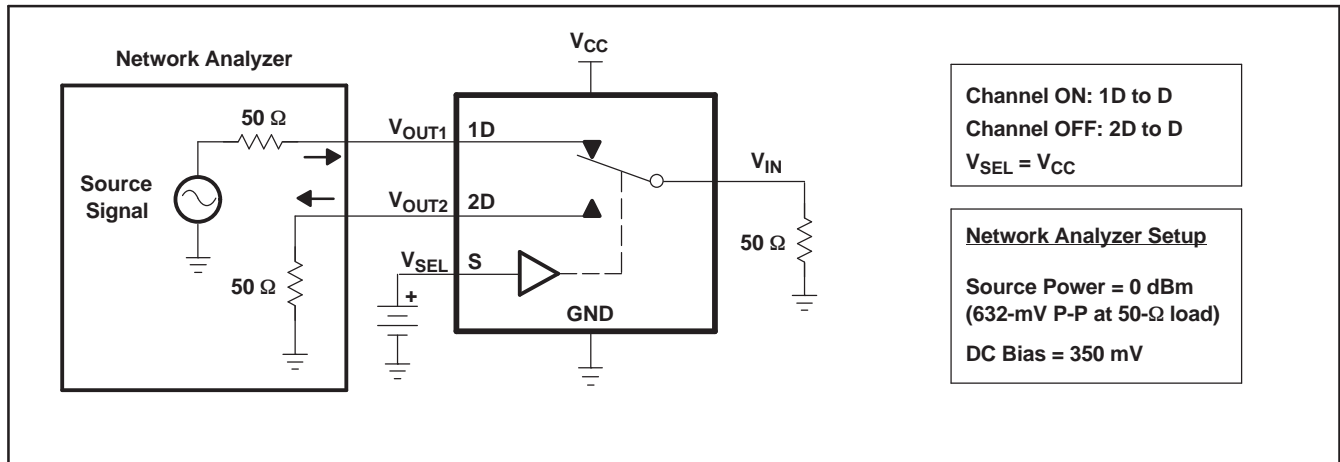

Figure 9. Crosstalk (X_{TALK})

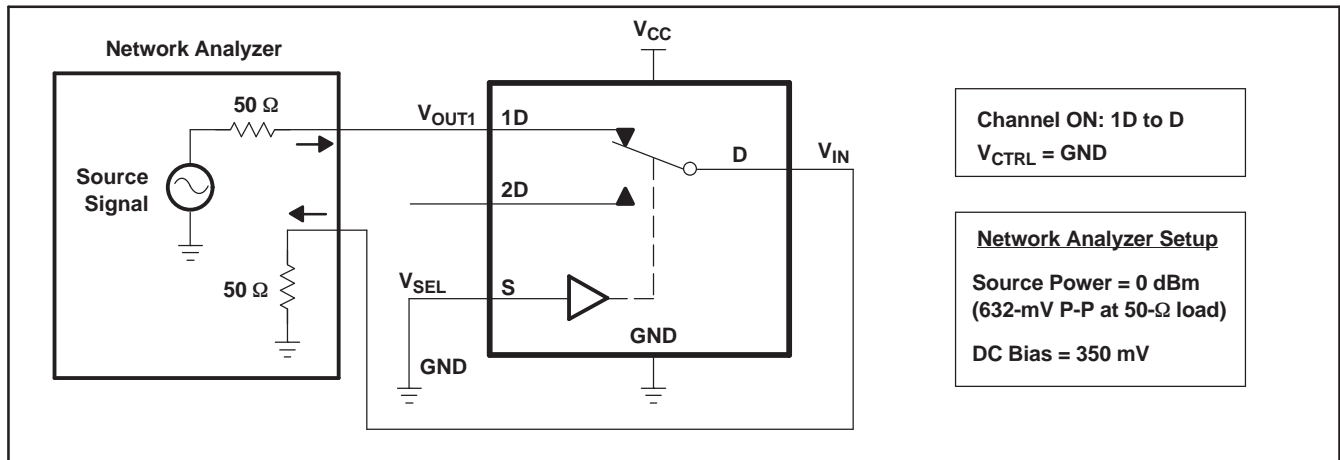

Figure 10. Bandwidth (BW)

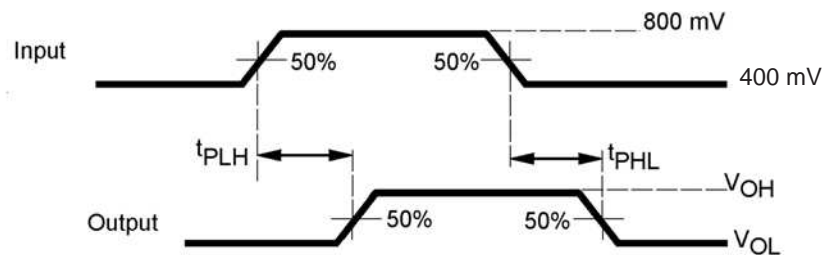

Figure 11. Propagation Delay

PARAMETER MEASUREMENT INFORMATION (continued)

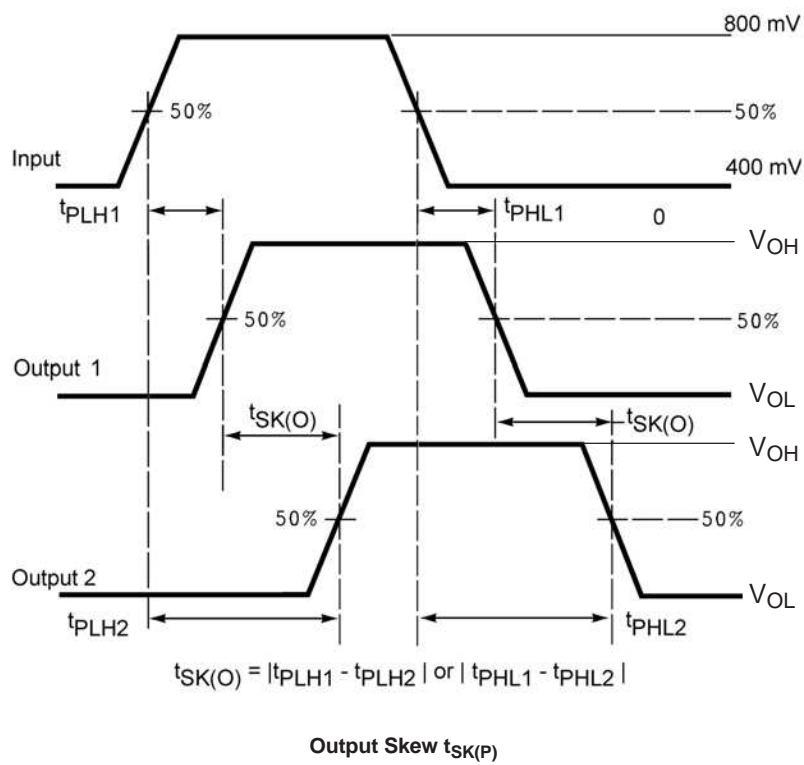
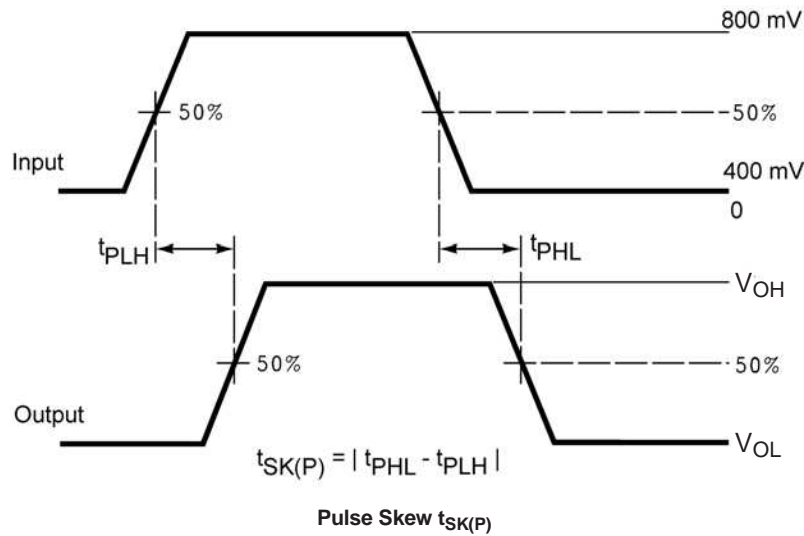

Figure 12. Skew Test

PARAMETER MEASUREMENT INFORMATION (continued)

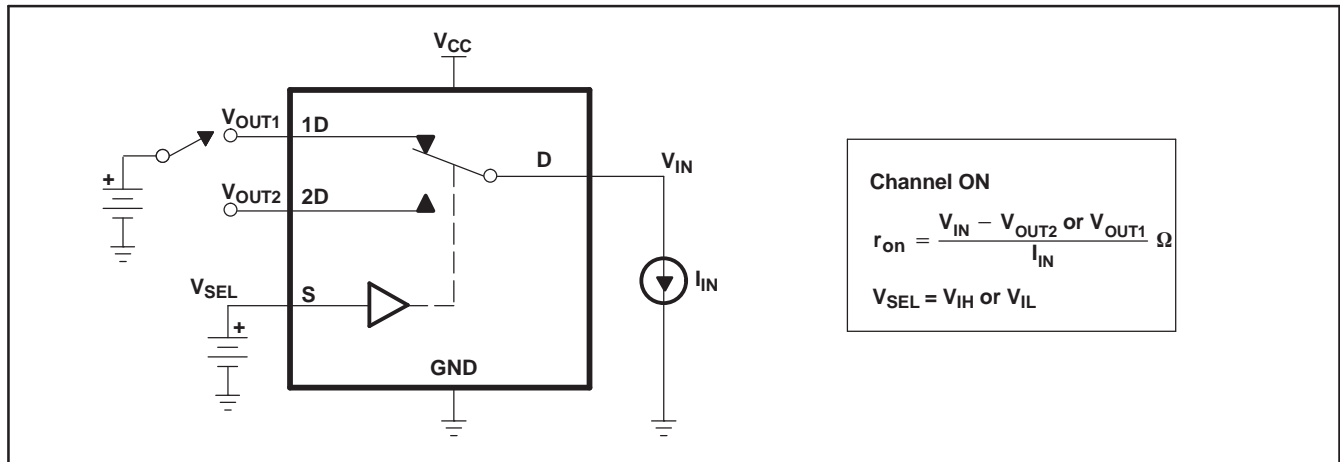

Figure 13. ON-State Resistance (r_{on})

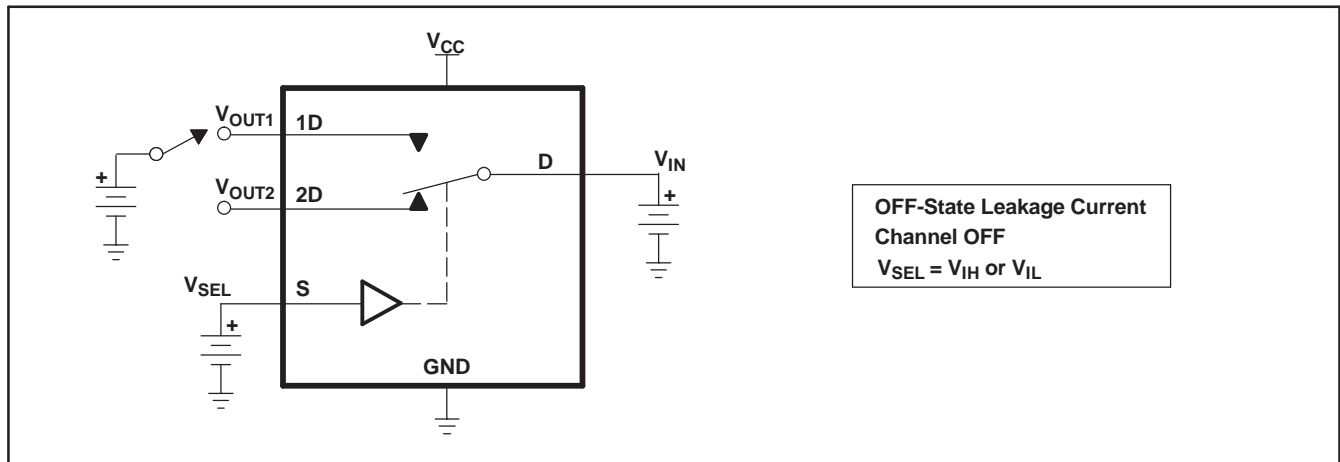

Figure 14. OFF-State Leakage Current

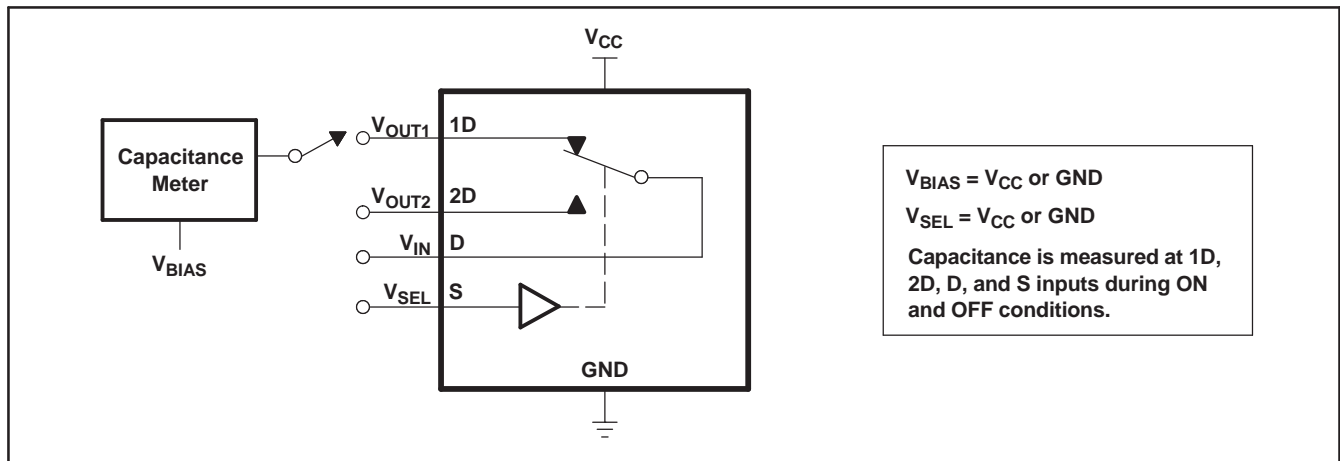

Figure 15. Capacitance

PACKAGING INFORMATION

Orderable Device	Status ⁽¹⁾	Package Type	Package Drawing	Pins	Package Qty	Eco Plan ⁽²⁾	Lead/Ball Finish	MSL Peak Temp ⁽³⁾
TS3USB31RSER	ACTIVE	UQFN	RSE	8	3000	Green (RoHS & no Sb/Br)	CU NIPDAU	Level-1-260C-UNLIM
TS3USB31RSERG4	ACTIVE	UQFN	RSE	8	3000	Green (RoHS & no Sb/Br)	CU NIPDAU	Level-1-260C-UNLIM

⁽¹⁾ The marketing status values are defined as follows:

ACTIVE: Product device recommended for new designs.

LIFEBUY: TI has announced that the device will be discontinued, and a lifetime-buy period is in effect.

NRND: Not recommended for new designs. Device is in production to support existing customers, but TI does not recommend using this part in a new design.

PREVIEW: Device has been announced but is not in production. Samples may or may not be available.

OBsolete: TI has discontinued the production of the device.

⁽²⁾ Eco Plan - The planned eco-friendly classification: Pb-Free (RoHS), Pb-Free (RoHS Exempt), or Green (RoHS & no Sb/Br) - please check <http://www.ti.com/productcontent> for the latest availability information and additional product content details.

TBD: The Pb-Free/Green conversion plan has not been defined.

Pb-Free (RoHS): TI's terms "Lead-Free" or "Pb-Free" mean semiconductor products that are compatible with the current RoHS requirements for all 6 substances, including the requirement that lead not exceed 0.1% by weight in homogeneous materials. Where designed to be soldered at high temperatures, TI Pb-Free products are suitable for use in specified lead-free processes.

Pb-Free (RoHS Exempt): This component has a RoHS exemption for either 1) lead-based flip-chip solder bumps used between the die and package, or 2) lead-based die adhesive used between the die and leadframe. The component is otherwise considered Pb-Free (RoHS compatible) as defined above.

Green (RoHS & no Sb/Br): TI defines "Green" to mean Pb-Free (RoHS compatible), and free of Bromine (Br) and Antimony (Sb) based flame retardants (Br or Sb do not exceed 0.1% by weight in homogeneous material)

⁽³⁾ MSL, Peak Temp. -- The Moisture Sensitivity Level rating according to the JEDEC industry standard classifications, and peak solder temperature.

Important Information and Disclaimer:The information provided on this page represents TI's knowledge and belief as of the date that it is provided. TI bases its knowledge and belief on information provided by third parties, and makes no representation or warranty as to the accuracy of such information. Efforts are underway to better integrate information from third parties. TI has taken and continues to take reasonable steps to provide representative and accurate information but may not have conducted destructive testing or chemical analysis on incoming materials and chemicals. TI and TI suppliers consider certain information to be proprietary, and thus CAS numbers and other limited information may not be available for release.

In no event shall TI's liability arising out of such information exceed the total purchase price of the TI part(s) at issue in this document sold by TI to Customer on an annual basis.

TAPE AND REEL INFORMATION

QUADRANT ASSIGNMENTS FOR PIN 1 ORIENTATION IN TAPE

*All dimensions are nominal

Device	Package Type	Package Drawing	Pins	SPQ	Reel Diameter (mm)	Reel Width W1 (mm)	A0 (mm)	B0 (mm)	K0 (mm)	P1 (mm)	W (mm)	Pin1 Quadrant
TS3USB31RSER	UQFN	RSE	8	3000	180.0	9.5	1.7	2.3	0.75	4.0	8.0	Q2
TS3USB31RSER	UQFN	RSE	8	3000	179.0	8.4	1.7	1.7	0.76	4.0	8.0	Q2
TS3USB31RSER	UQFN	RSE	8	3000	180.0	8.4	1.6	1.6	0.66	4.0	8.0	Q2

TAPE AND REEL BOX DIMENSIONS

*All dimensions are nominal

Device	Package Type	Package Drawing	Pins	SPQ	Length (mm)	Width (mm)	Height (mm)
TS3USB31RSER	UQFN	RSE	8	3000	180.0	180.0	30.0
TS3USB31RSER	UQFN	RSE	8	3000	203.0	203.0	35.0
TS3USB31RSER	UQFN	RSE	8	3000	202.0	201.0	28.0

RSE (S-PUQFN-N8)

PLASTIC QUAD FLATPACK NO-LEAD

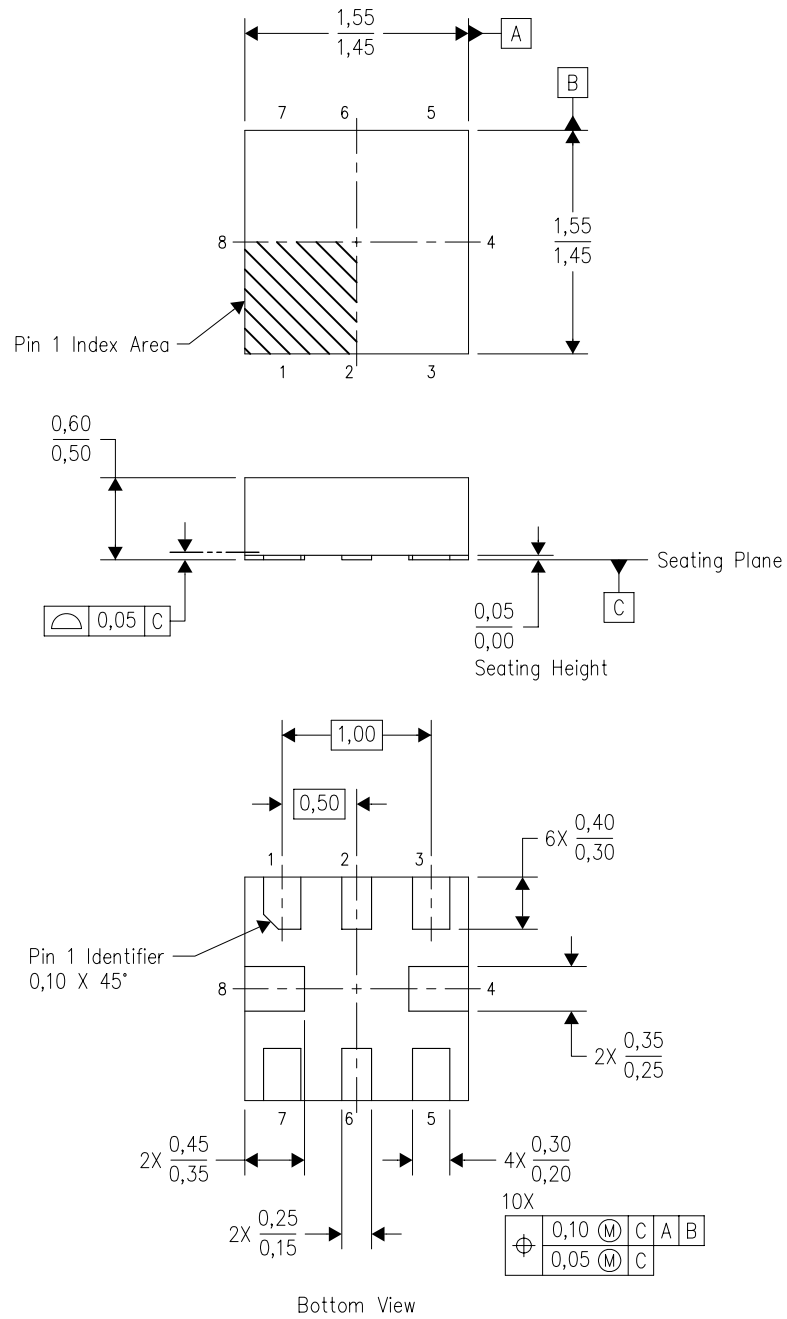

4207268-2/D 01/11

- NOTES:
- A. All linear dimensions are in millimeters. Dimensioning and tolerancing per ASME Y14.5M-1994.
 - B. This drawing is subject to change without notice.
 - C. QFN (Quad Flatpack No-Lead) package configuration.
 - D. This package complies to JEDEC MO-288 variation UECD.

RSE (S-PUQFN-N8)

PLASTIC QUAD FLATPACK NO-LEAD

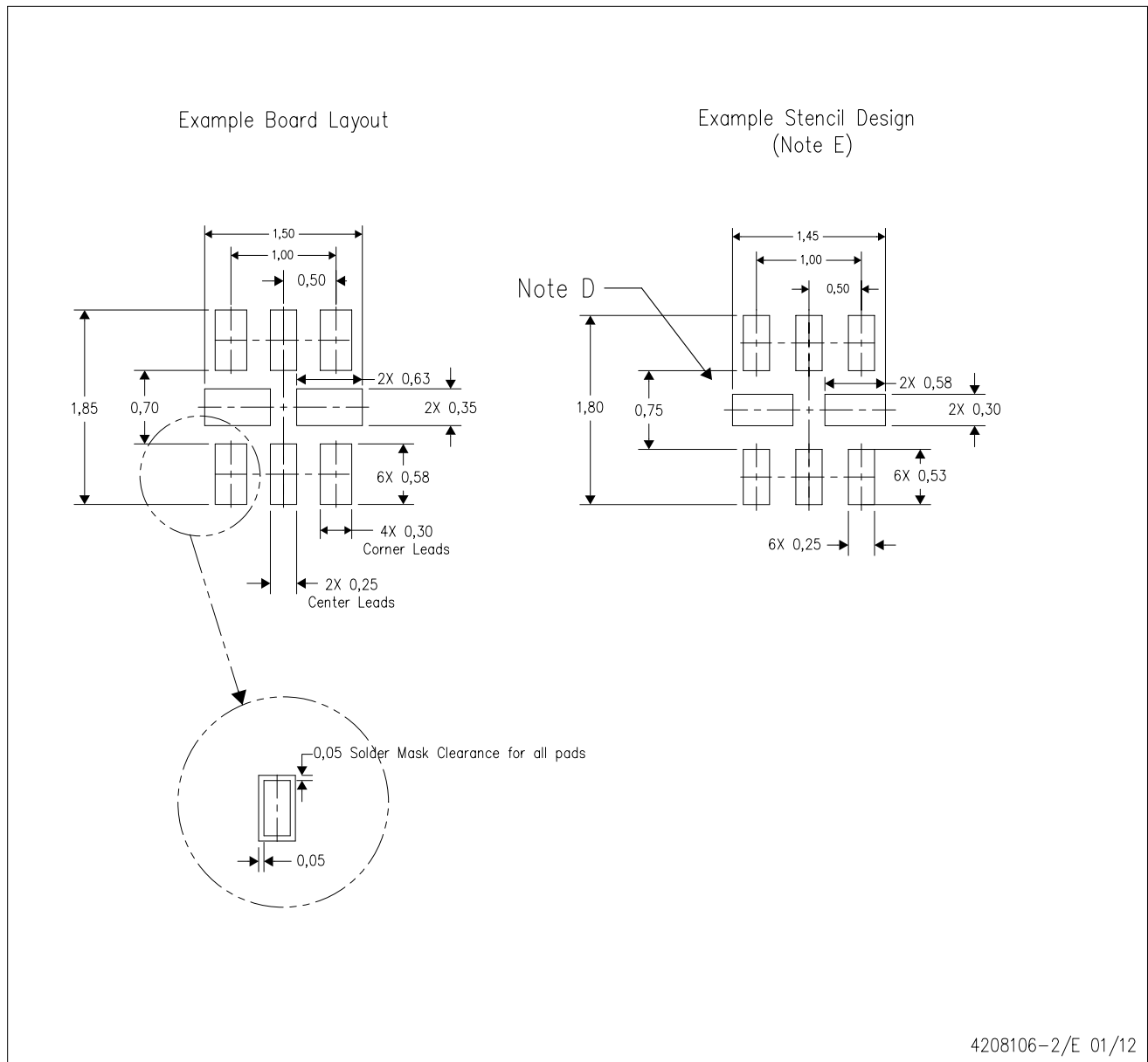

- NOTES:
- A. All linear dimensions are in millimeters.
 - B. This drawing is subject to change without notice.
 - C. Publication IPC-7351 is recommended for alternate designs.
 - D. Customers should contact their board fabrication site for minimum solder mask web tolerances between signal pads.
 - E. Maximum stencil thickness 0,127 mm (5 mils). All linear dimensions are in millimeters.
 - F. Laser cutting apertures with trapezoidal walls and also rounding corners will offer better paste release. Customers should contact their board assembly site for stencil design recommendations. Refer to IPC 7525 for stencil design considerations.
 - G. Side aperture dimensions over-print land for acceptable area ratio > 0.66. Customer may reduce side aperture dimensions if stencil manufacturing process allows for sufficient release at smaller opening.

IMPORTANT NOTICE

Texas Instruments Incorporated and its subsidiaries (TI) reserve the right to make corrections, enhancements, improvements and other changes to its semiconductor products and services per JESD46, latest issue, and to discontinue any product or service per JESD48, latest issue. Buyers should obtain the latest relevant information before placing orders and should verify that such information is current and complete. All semiconductor products (also referred to herein as "components") are sold subject to TI's terms and conditions of sale supplied at the time of order acknowledgment.

TI warrants performance of its components to the specifications applicable at the time of sale, in accordance with the warranty in TI's terms and conditions of sale of semiconductor products. Testing and other quality control techniques are used to the extent TI deems necessary to support this warranty. Except where mandated by applicable law, testing of all parameters of each component is not necessarily performed.

TI assumes no liability for applications assistance or the design of Buyers' products. Buyers are responsible for their products and applications using TI components. To minimize the risks associated with Buyers' products and applications, Buyers should provide adequate design and operating safeguards.

TI does not warrant or represent that any license, either express or implied, is granted under any patent right, copyright, mask work right, or other intellectual property right relating to any combination, machine, or process in which TI components or services are used. Information published by TI regarding third-party products or services does not constitute a license to use such products or services or a warranty or endorsement thereof. Use of such information may require a license from a third party under the patents or other intellectual property of the third party, or a license from TI under the patents or other intellectual property of TI.

Reproduction of significant portions of TI information in TI data books or data sheets is permissible only if reproduction is without alteration and is accompanied by all associated warranties, conditions, limitations, and notices. TI is not responsible or liable for such altered documentation. Information of third parties may be subject to additional restrictions.

Resale of TI components or services with statements different from or beyond the parameters stated by TI for that component or service voids all express and any implied warranties for the associated TI component or service and is an unfair and deceptive business practice. TI is not responsible or liable for any such statements.

Buyer acknowledges and agrees that it is solely responsible for compliance with all legal, regulatory and safety-related requirements concerning its products, and any use of TI components in its applications, notwithstanding any applications-related information or support that may be provided by TI. Buyer represents and agrees that it has all the necessary expertise to create and implement safeguards which anticipate dangerous consequences of failures, monitor failures and their consequences, lessen the likelihood of failures that might cause harm and take appropriate remedial actions. Buyer will fully indemnify TI and its representatives against any damages arising out of the use of any TI components in safety-critical applications.

In some cases, TI components may be promoted specifically to facilitate safety-related applications. With such components, TI's goal is to help enable customers to design and create their own end-product solutions that meet applicable functional safety standards and requirements. Nonetheless, such components are subject to these terms.

No TI components are authorized for use in FDA Class III (or similar life-critical medical equipment) unless authorized officers of the parties have executed a special agreement specifically governing such use.

Only those TI components which TI has specifically designated as military grade or "enhanced plastic" are designed and intended for use in military/aerospace applications or environments. Buyer acknowledges and agrees that any military or aerospace use of TI components which have **not** been so designated is solely at the Buyer's risk, and that Buyer is solely responsible for compliance with all legal and regulatory requirements in connection with such use.

TI has specifically designated certain components which meet ISO/TS16949 requirements, mainly for automotive use. Components which have not been so designated are neither designed nor intended for automotive use; and TI will not be responsible for any failure of such components to meet such requirements.

Products

Audio	www.ti.com/audio
Amplifiers	amplifier.ti.com
Data Converters	dataconverter.ti.com
DLP® Products	www.dlp.com
DSP	dsp.ti.com
Clocks and Timers	www.ti.com/clocks
Interface	interface.ti.com
Logic	logic.ti.com
Power Mgmt	power.ti.com
Microcontrollers	microcontroller.ti.com
RFID	www.ti-rfid.com
OMAP Applications Processors	www.ti.com/omap
Wireless Connectivity	www.ti.com/wirelessconnectivity

Applications

Automotive and Transportation	www.ti.com/automotive
Communications and Telecom	www.ti.com/communications
Computers and Peripherals	www.ti.com/computers
Consumer Electronics	www.ti.com/consumer-apps
Energy and Lighting	www.ti.com/energy
Industrial	www.ti.com/industrial
Medical	www.ti.com/medical
Security	www.ti.com/security
Space, Avionics and Defense	www.ti.com/space-avionics-defense
Video and Imaging	www.ti.com/video

TI E2E Community

e2e.ti.com