

AXL F AO4 1H

Axioline F analog output module, 4 outputs

Data sheet
8660_en_02

© PHOENIX CONTACT 2015-04-20



1 Description

The module is designed for use within an Axioline F station. It is used to output analog voltage and current signals.

Features

- 4 analog output channels for the connection of either voltage or current signals
- Bipolar voltage outputs, unipolar current outputs
- Connection of actuators in 2-wire technology
- Voltage ranges: 0 V ... 10 V, ± 10 V, 0 V ... 5 V, ± 5 V
- Current ranges: 0 mA ... 20 mA, 4 mA ... 20 mA
- Short-circuit-proof outputs
- No derating in all ranges
- Short signal rise time
- Driving of high loads
- Device type label stored
- Diagnostic and status indicators



This data sheet is only valid in association with the UM EN AXL F SYS INST user manual.



Make sure you always use the latest documentation. It can be downloaded from the product at phoenixcontact.net/products.

2	Table of contents	
1	Description	1
2	Table of contents	2
3	Ordering data	3
4	Technical data	3
5	Tolerance data.....	6
6	Signal rise times	6
7	Internal circuit diagram	7
8	Terminal point assignment.....	8
9	Connection example.....	8
10	Connection notes	8
11	Local status and diagnostic indicators	9
12	Process data.....	11
	12.1 OUT process data.....	11
	12.2 IN process data.....	11
13	Significant values in various formats.....	12
	13.1 Significant values in IB IL format	12
	13.2 Significant values in S7-compatible format	12
14	Parameter, diagnostics and information (PDI)	13
15	Standard objects	14
	15.1 Objects for identification (device rating plate).....	14
	15.2 Object for multilingual capacity.....	15
	15.3 Object descriptions	15
	15.4 Diagnostics objects	15
	15.5 Objects for process data management.....	17
	15.6 Objects for device management	21
16	Application objects	23
	16.1 Parameter table (0080hex: ParaTable).....	23
17	Writing the analog values over the PDI channel.....	24
18	Device descriptions	24

3 Ordering data

Description	Type	Order No.	Pcs./Pkt.
Axioline F analog output module, 4 outputs: 0 - 10 V, ±10 V, 0 - 5 V, ±5 V, 0 - 20 mA, 4 - 20 mA, 2-wire connection technology (including bus base module and connectors)	AXL F AO4 1H	2688527	1
Accessories	Type	Order No.	Pcs./Pkt.
Axioline F bus base module for housing type H (Replacement item)	AXL F BS H	2700992	5
Axioline shield connection set (contains 2 busbar holders and 2 SK 5 shield connection clamps)	AXL SHIELD SET	2700518	1
Zack marker strip for Axioline F (device labeling), in 2 x 20.3 mm pitch, unprinted, 25-section, for individual labeling with B-STIFT 0.8, X-PEN, or CMS-P1-PLOTTER (Marking)	ZB 20,3 AXL UNPRINTED	0829579	25
Zack marker strip, flat, in 10 mm pitch, unprinted, 10-section, for individual labeling with M-PEN 0,8, X-PEN, or CMS-P1-PLOTTER (Marking)	ZBF 10/5,8 AXL UNPRINTED	0829580	50
Insert label, Roll, white, unlabeled, can be labeled with: THERMOMARK ROLL, THERMOMARK ROLL X1, THERMOMARK X, THERMOMARK S1.1, Mounting type: snapped into marker carrier, Lettering field: 35 x 28 mm (Marking)	EMT (35X28)R	0801602	1
Documentation	Type	Order No.	Pcs./Pkt.
User manual, English, Axioline F: System and installation	UM EN AXL F SYS INST	-	-
User manual, English, Axioline F: Diagnostic registers, and error messages	UM EN AXL F SYS DIAG	-	-

4 Technical data

Dimensions (nominal sizes in mm)

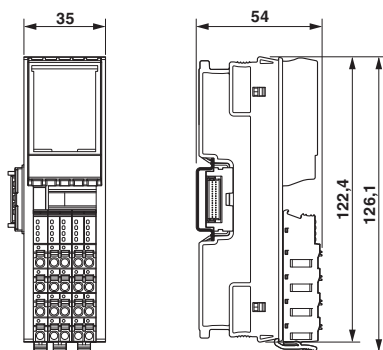

Width	35 mm
Height	126.1 mm
Depth	54 mm
Note on dimensions	The depth is valid when a TH 35-7.5 DIN rail is used (according to EN 60715).

General data

Color	traffic grey A RAL 7042
Weight	145 g (with connectors and bus base module)
Ambient temperature (operation)	-25 °C ... 60 °C
Ambient temperature (storage/transport)	-40 °C ... 85 °C

General data

Permissible humidity (operation)	5 % ... 95 % (non-condensing)
Permissible humidity (storage/transport)	5 % ... 95 % (non-condensing)
Air pressure (operation)	70 kPa ... 106 kPa (up to 3000 m above sea level)
Air pressure (storage/transport)	70 kPa ... 106 kPa (up to 3000 m above sea level)
Degree of protection	IP20
Protection class	III, IEC 61140, EN 61140, VDE 0140-1
Mounting position	Any (no temperature derating)

Connection data

Designation	Axioline F connector
Connection method	Push-in technology
Conductor cross section solid / stranded	0.2 mm ² ... 1.5 mm ² / 0.2 mm ² ... 1.5 mm ²
Conductor cross section [AWG]	24 ... 16
Stripping length	8 mm

Interface Axioline F local bus

Connection method	Bus base module
Transmission speed	100 MBit/s

Communications power

Communications power U_{BUS}	5 V DC (via bus base module)
Current consumption from U_{BUS}	typ. 120 mA, max. 150 mA

I/O supply

Supply of analog modules U_A	24 V DC
Maximum permissible voltage range	19.2 V DC ... 30 V DC (including all tolerances, including ripple)
Current consumption from U_A	typ. 40 mA (induced current consumption; no load, 0 V output) typ. 60 mA (4 voltage channels, 10 V output) max. 110 mA (4 current channels, 20 mA output, 500 Ω load)
Surge protection	Electronic (35 V, 0.5 s)
Protection against polarity reversal	Polarity protection diode
Transient protection	Suppressor diode

Total power consumption of the module

Power consumption	typ. 2.04 W (at U_{BUS} and U_A), max. 3.39 W (at U_{BUS} and U_A)
-------------------	--

Analog outputs

Number of outputs	4
Connection method	Push-in technology
Connection method	2-wire (shielded, twisted pair)
D/A resolution	16 bit
Representation of output values	16 bits (15 bits + sign)
Data formats	IB IL, S7-compatible
Process data update	140 μ s
Short-circuit and overload protection	Electronic
Transient protection	Suppressor diode

Analog outputs, Current

Current output signal	0 mA ... 20 mA, 4 mA ... 20 mA
Load/output load current output	\leq 500 Ω
Precision	typ. 0.1 % (of output range final value)

Analog outputs, Voltage

Voltage output signal	0 V ... 5 V, -5 V ... 5 V, 0 V ... 10 V, -10 V ... 10 V
Load/output load voltage output	> 1 kΩ
Precision	typ. 0.1 % (of output range final value)

Configuration and parameter data in a PROFIBUS system

Required parameter data	14 Byte
Need for configuration data	7 Byte

Electrical isolation/isolation of the voltage areas

Test section	Test voltage
5 V communications power (logic), 24 V supply (I/O)	500 V AC, 50 Hz, 1 min
5 V supply (logic)/analog outputs	500 V AC, 50 Hz, 1 min
5 V supply (logic)/functional earth ground	500 V AC, 50 Hz, 1 min
24 V supply (I/O)/analog outputs	500 V AC, 50 Hz, 1 min
24 V supply (I/O) / functional earth ground	500 V AC, 50 Hz, 1 min
Analog outputs/functional earth ground	500 V AC, 50 Hz, 1 min

Mechanical tests

Vibration resistance in acc. with EN 60068-2-6/IEC 60068-2-6	5g
Shock in acc. with EN 60068-2-27/IEC 60068-2-27	30g
Continuous shock according to EN 60068-2-27/IEC 60068-2-27	10g

Conformance with EMC Directive 2004/108/EC

Noise immunity test in accordance with EN 61000-6-2

Electrostatic discharge (ESD) EN 61000-4-2/IEC 61000-4-2	Criterion B; 6 kV contact discharge, 8 kV air discharge
Electromagnetic fields EN 61000-4-3/IEC 61000-4-3	Criterion A; Field intensity: 10 V/m
Fast transients (burst) EN 61000-4-4/IEC 61000-4-4	Criterion B, 2 kV
Transient surge voltage (surge) EN 61000-4-5/IEC 61000-4-5	Criterion B; supply lines DC: ±0.5 kV/±0.5 kV (symmetrical/asymmetrical); ±1 kV to shielded I/O cables
Conducted interference EN 61000-4-6/IEC 61000-4-6	Criterion A; Test voltage 10 V

Noise emission test according to EN 61000-6-3

Radio interference properties EN 55022	Class B
--	---------

Approvals

For the latest approvals, please visit phoenixcontact.net/products.

5 Tolerance data

Tolerances at $T_A = 25^\circ\text{C}$				
	Absolute tolerance		Relative tolerance	
	Typ.	Max.	Typ.	Max.
0 V ... 5 V, ± 5 V, 0 V ... 10 V, ± 10 V	± 10 mV	± 30 mV	$\pm 0.10\%$	$\pm 0.30\%$
0 mA ... 20 mA, 4 mA ... 20 mA	± 20 μA	± 60 μA	$\pm 0.10\%$	$\pm 0.30\%$

Typical data contains offset error, gain error, and linearity error in the respective default setting.

All tolerances indicated as a percentage are related to the positive output range final value.

The data is valid for nominal operation ($U_A = 24$ V in the default configuration).

Default configuration: IB IL format

Please also observe the values for temperature drift and the tolerances under influences of electromagnetic interferences.

The maximum tolerance values represent the worst case measurement inaccuracy. Besides maximum offset and gain drift, they also comprise longtime drift as well as the maximum tolerances of the test and calibration equipment.

Tolerance and temperature response at $T_A = -25^\circ\text{C}$ to $+60^\circ\text{C}$		
	Drift	
	Typical	Maximum
0 V ... 5 V, ± 5 V, 0 V ... 10 V, ± 10 V	± 25 ppm/K	± 70 ppm/K
0 mA ... 20 mA, 4 mA ... 20 mA	± 25 ppm/K	± 70 ppm/K

The drift values refer to the relevant output range final value.

The values refer to nominal operation with default settings.

Tolerances influenced by electromagnetic interference		
Electromagnetic fields	EN 61000-4-3/ IEC 61000-4-3	< 0.1 %
Fast transients (burst)	EN 61000-4-4/ IEC 61000-4-4	< 0.1 %
Conducted interference	EN 61000-4-6/ IEC 61000-4-6	< 0.1 %

All tolerances indicated as a percentage are related to the positive output range final value.

Additional tolerances may occur due to the influence of high-frequency electromagnetic interference caused by wireless transmission systems in the near vicinity. The values specified refer to nominal operation in the event of direct interfer-

ence to components without additional shielding such as a steel cabinet, etc.

The above mentioned tolerances can be reduced by providing further shielding measures for the I/O module (e.g., use of a shielded control box/control cabinet, etc.).

6 Signal rise times

Voltage step 0 V ... 10 V (typical values)

Load	Time for 0 % ... 99 %
$R_L = 1$ k Ω	30 μs
$R_L = 1$ k Ω $C_L = 10$ nF	30 μs
$R_L = 1$ k Ω $C_L = 220$ nF	215 μs
$R_L = 1$ k Ω + $L_L = 3$ mH	35 μs

Current step 0 mA ... 20 mA (typical values)

Load	Time for 0 % ... 99 %
$R_L = 500$ Ω	125 μs
$R_L = 500$ Ω $C_L = 10$ nF	130 μs
$R_L = 500$ Ω $C_L = 220$ nF	300 μs
$R_L = 500$ Ω + $L_L = 2$ mH	1 ms

Key to the tables

R_L	Ohmic load
C_L	Capacitive load
L_L	Inductive load
	Parallel connection
+	Serial connection

7 Internal circuit diagram

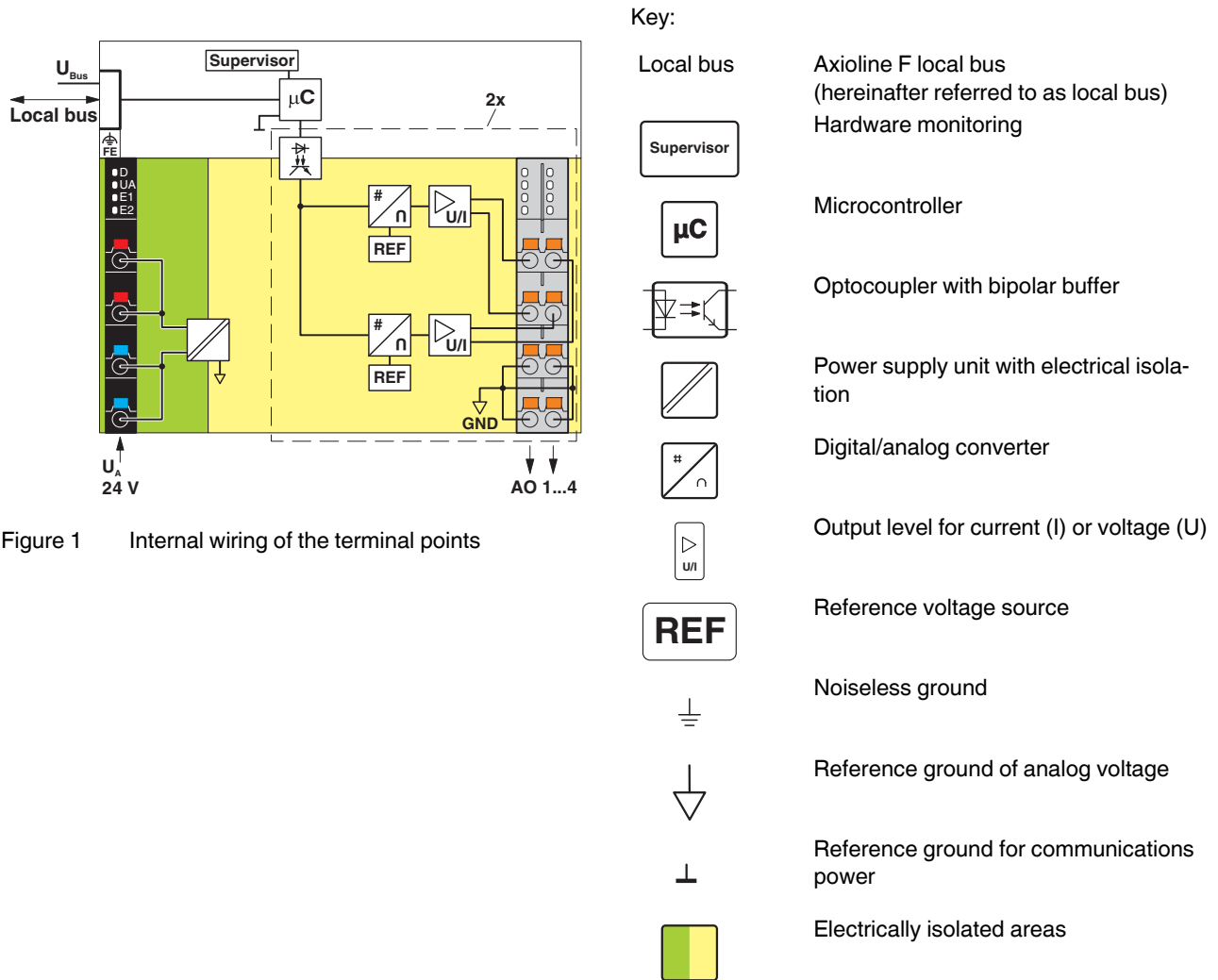

Figure 1 Internal wiring of the terminal points

8 Terminal point assignment

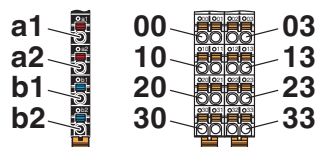

Figure 2 Terminal point assignment

Terminal point	Color	Assignment	
Supply voltage input			
a1, a2	Red	24 V DC (U _A)	Analog module supply (internally jumpered)
b1, b2	Blue	GND	Reference potential of the supply voltage (internally jumpered)
Analog outputs			
00 ... 03	Orange	U1 ... U4	Voltage connection for channel 1 ... 4
10 ... 13	Orange	I1 ... I4	Current connection for channel 1 ... 4
20 ... 23, 30 ... 33	Orange	GND	Reference potential for all channels

9 Connection example

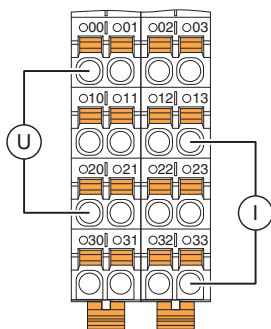

Figure 3 Connection for voltage and current output

10 Connection notes



NOTE: Damage to the electronics/measuring errors

Always connect the analog actuators using shielded twisted-pair cables.

Unshielded cables may lead to values outside the specified tolerance limits in environments subject to heavy noise.

Connect the cable shield to functional earth immediately after the cables enter the control cabinet.

If there is no closed control cabinet, connect the shield to a shield bus.

Use the AXL SHIELD SET Axiline shield connection set for an optimized connection directly in front of the module.



For further information on shielding, please refer to the UM EN AXL SYS INST user manual.

11 Local status and diagnostic indicators



Channel errors are errors that can be associated with a channel.
Periphery errors are errors that affect the entire module.

Figure 4 Local status and diagnostic indicators

Designation	Color	Meaning	State	Description
D	Red/yellow/green	Diagnostics of local bus communication		
		Power down	OFF	Device in (power) reset.
		Not connected	Red flashing	The device is ready for operation but there is no connection to the previously existing device.
		Reset	Red ON	The device is ready for operation but has lost the connection to the bus head.
		Ready	Yellow ON	The device is ready for operation but did not detect a valid cycle after power-on.
		Connected	Yellow flashing	The device is not (yet) part of the active configuration.
		Device application not active	Flashing green/yellow	Valid data cycles are being detected. The master application set the output data to valid, however, the slave application has not yet output the output data.
		Active	Green flashing	Device operating, communications within the station is OK. The master application has not yet set the output data to valid. (The connection to the controller has not yet been established, for example.)
Run	Green ON	The device is ready for operation, communication within the station is OK. All data is valid. There are no faults.		
UA	Green	U _{Analog}	ON	Supply of analog modules present
			OFF	Supply of analog modules not present
E1	Red	Supply voltage error	ON	Supply voltage is faulty.
			OFF	Supply voltage is present.
E2	Red	Error	ON	I/O or channel error has occurred.
			OFF	No error

Error code and status of the E1 and E2 LEDs

Error	E1 LED	E2 LED
No error	OFF	OFF
Short-circuit	OFF	ON
Open circuit	OFF	ON
Faulty supply voltage	ON	ON
Parameter table invalid	OFF	ON
Device error	OFF	ON
Flash format error	OFF	ON



A short circuit or open circuit is detected when the output value is $> 1.7\%$ of the output range final value.

If you output a value when the actuator is not connected, a open circuit message is generated.

12 Process data

The module uses four words of IN process data and four words of OUT process data. Each channel is mapped to a word.

12.1 OUT process data

The output values are transmitted from the controller board or the computer to the module using process data output words OUT1 to OUT4.

Order of the process data words

OUT1	...	OUT4
Channel 1	...	Channel 4
AV	...	AV

AV Output value

Output value

The output values are mapped in IB IL format or S7-compatible format. In both formats the output value is represented in bits 14 to 0. An additional bit (bit 15) is available as a sign bit.

15	14	13	12	11	10	9	8	7	6	5	4	3	2	1	0
V	Analog value														

V Sign bit

12.2 IN process data



In the case of Sercos, the IN process data is hidden and therefore unavailable.

The following data is transmitted in the input process data:

- During normal error-free operation, the output value is mirrored in the input process data for each channel.
- If an error occurs, the diagnostic message is mirrored (in IB IL format) in the input process data for each channel. The diagnostics message is deleted as soon as the error is eliminated.

Order of the process data words

IN1	...	IN4
Channel 1	...	Channel 4
AW*/Diag	...	AW*/Diag

AW*/Diag Mirrored output value or diagnostics messages (in IB IL format)

Diagnostic message (in IB IL format)

Code (hex)	Cause
8002	Open circuit
8003	Short-circuit
8010	Parameter table invalid
8020	Faulty supply voltage
8040	Device faulty



In the event of error, a currently existing error is mirrored in the process data on the corresponding channel.

13 Significant values in various formats

13.1 Significant values in IB IL format

Output data		0 V ... 10 V	± 10 V	0 V ... 5 V	± 5 V	0 mA ... 20 mA	4 mA ... 20 mA
hex	dec	V	V	V	V	mA	mA
7FFF ... 7F01		+10.837	+10.837	+5.419	+5.419	+21.6747	+21.3397
7F00	32512	+10.837	+10.837	+5.419	+5.419	+21.6747	+21.3397
7530	30000	+10.0	+10.0	+5.0	+5.0	+20.0	+20.0
3A98	15000	+5.0	+5.0	+2.5	+2.5	+10.0	+12.0
0001	1	+333.33 µV	+333.33 µV	+166.67 µV	+166.67 µV	+0.6667 µA	+4.0005333
0000	0	0	0	0	0	0	+4.0
FFFF	-1	0	-333.33 µV	0	-166.67 µV	0	+4.0
C568	-15000	0	-5.0	0	-2.5	0	+4.0
8AD0	-30000	0	-10.0	0	-5.0	0	+4.0
8100	-32512	0	-10.837	0	-5.419	0	+4.0
80FF ... 8000*		Hold last value	Hold last value	Hold last value	Hold last value	Hold last value	Hold last value
8001	Overrange	+10.837	+10.837	+5.419	+5.419	+21.6747	+21.3397
8080	Underrange	0	-10.837	0	-5.419	0	Hold last value

* without 8001, 8080

13.2 Significant values in S7-compatible format

Output data		0 V ... 10 V	± 10 V	0 V ... 5 V	± 5 V	0 mA ... 20 mA	4 mA ... 20 mA
hex	dec	V	V	V	V	mA	mA
7FFF ... 7F00	Overrange	0	0	0	0	0	0
7EFF	32511	+11.759	+11.759	+5.879	+5.879	+23.5157	+22.8142
6C00	27648	+10.0	+10.0	+5.0	+5.0	+20.0	+20.0
5100	20736	+7.5	+7.5	+3.75	+3.75	+15.0	+16.0
0001	1	+361.69 µV	+361.69 µV	+180.85 µV	+180.85 µV	+0.7234 µA	+4.0005787
0000	0	0	0	0	0	0	+4.0
FFFF	-1	0	-361.69 µV	0	-180.85 µV	0	+3.9994
E501	-6911	0	-2.4996	0	-1.2498	0	0.578 µA
E500	-6912	0	-2.5	0	-1.25	0	0
AF00	-20736	0	-7.5	0	-3.75	0	0
9400	-27648	0	-10.0	0	-5.0	0	0
8100	-32512	0	-11.759	0	-5.879	0	0
80FF ... 8000	Underrange	0	0	0	0	0	0

14 Parameter, diagnostics and information (PDI)

Parameter and diagnostic data as well as other information is transmitted via the PDI channel of the Axioline F station.

The standard and application objects stored in the module are described in the following section.

The following applies to all tables below:

Please refer to the UM EN AXL F SYS INST for an explanation of the object codes and data types.

Abbreviation	Meaning
A	Number of elements
L	Length of the elements in bytes
R	Read
W	Write



Every visible string is terminated with a zero terminator (00_{hex}). The length of a visible string element is therefore one byte larger than the amount of user data.



For detailed information on PDI and the objects, please refer to the UM EN AXL F SYS INST user manual.

15 Standard objects

15.1 Objects for identification (device rating plate)

Index (hex)	Object name	Object type	Data type	A	L	Rights	Meaning	Contents
Manufacturer								
0001	VendorName	Var	Visible String	1	16	R	Vendor name	Phoenix Contact
0002	VendorID	Var	Visible String	1	7	R	Vendor ID	00A045
0003	VendorText	Var	Visible String	1	49	R	Vendor text	Components and systems for industrial automation
0012	VendorURL	Var	Visible String	1	30	R	Vendor URL	http://www.phoenix-contact.com
Module - general								
0004	DeviceFamily	Var	Visible String	1	15	R	Device family	I/O analog OUT
0006	ProductFamily	Var	Visible String	1	6	R	Product family	AXL F
000E	CommProfile	Var	Visible String	1	4	R	Communication profile	633
000F	DeviceProfile	Var	Visible String	1	5	R	Device profile	0010
0011	ProfileVersion	Record	Visible String	2	11; 20	R	Profile version	2011-12-07; Basic Profile V2.0
003A	VersionCount	Array	Unsigned 16	4	4 * 2	R	Version counter	e. g., 0007 0001 0001 0001 _{hex}
Module - special								
0005	Capabilities	Array	Visible String	1	8	R	Features	Energ_0
0007	ProductName	Var	Visible String	1	13	R	Product name	AXL F AO4 1H
0008	SerialNo	Var	Visible String	1	11	R	Serial number	xxxxxxxx (e. g., 1234512345)
0009	ProductText	Var	Visible String	1	25	R	Product text	4 analog output channels
000A	OrderNumber	Var	Visible String	1	8	R	Order No.	2688527
000B	HardwareVersion	Record	Visible String	2	11; 3	R	Hardware version	e. g., 2010-06-21; 01
000C	FirmwareVersion	Record	Visible String	2	11; 6	R	Firmware version	e. g., 2010-06-21; V1.10
000D	PChVersion	Record	Visible String	2	11; 6	R	Parameter channel version	2010-01-08; V1.00
0037	DeviceType	Var	Octet string	1	8	R	Module identification	00 10 00 08 00 00 00 A7 _{hex}
Use of the device								
0014	Location	Var	Visible String	1	59	R/W	Location	Can be filled out by the user.
0015	EquipmentIdent	Var	Visible String	1	59	R/W	Equipment identifier	Can be filled out by the user.
0016	AppIDeviceAddr	Var	Unsigned 16	1	2	R/W	Application device address	Can be filled out by the user.

15.2 Object for multilingual capacity

Index (hex)	Object name	Object type	Data type	A	L	Rights	Meaning	Contents
0017	Language	Record	Visible String	2	6; 8	R	Language	en-us; English

15.3 Object descriptions

Index (hex)	Object name	Object type	Data type	A	L	Rights	Meaning
0038	ObjDescrReq	Record		2	3	Read, write	Object description request
0039	ObjDescr	Record		16	See subindices	Read	Object description
003B	PDIN_Descr	Record		3	12	R	Description of the IN process data
003C	PDOOUT_Descr	Record		3	12	R	Description of the output process data



These objects are only important for tools and are therefore not described in more detail here.
Please refer to the basic profile for comprehensive information.

15.4 Diagnostics objects

Index (hex)	Object name	Object type	Data type	A	L	Rights	Assignment
0018	DiagState	Record		6	2; 1; 1; 2; 1; 14	R	Diagnostic state
0019	ResetDiag	Var	Unsigned 8	1	1	W	Reset diagnostics

Diagnostics state (0018_{hex}: DiagState)

This object is used for a structured message of an error.

0018 _{hex} : DiagState (Read)				
Subindex	Data type	Length in bytes	Meaning	Contents
0	Record	21	Diagnostic state	Complete diagnostics information
1	Unsigned 16	2	Error number	0 ... 65535 _{dez}
2	Unsigned 8	1	Priority	00 _{hex} No error
				01 _{hex} Error
				02 _{hex} Warning
				81 _{hex} Error removed
				82 _{hex} Warning eliminated
3	Unsigned 8	1	Channel/group/module	00 _{hex} No error
				01 _{hex} Channel 1
				: :
				04 _{hex} Channel 4
				FF _{hex} entire device
4	Unsigned 16	2	Error code	See table below
5	Unsigned 8	1	More follows	00 _{hex}
6	Visible String	14	Text (14 characters)	See table below



The message with the priority 81_{hex} or 82_{hex} is a one-time internal message to the bus coupler that is implemented onto the error mechanisms of the higher-level system by the bus coupler.

Error and status of the local status and diagnostics indicators

Subindex	2	3	4		6	Process data	LED			
	Priority	Channel/ group/ module	Error code		Text		D	UA	E1	E2
Error	hex	hex	hex	dec						
No error	00	00	0000	0	Status OK	xxxx	Green ON	ON	OFF	OFF
Short-circuit	01	01 ... 04	2130	8496	Short-circuit	8003	Green ON	ON	OFF	ON
Faulty supply voltage	01	FF	5160	20832	Supply fail	8020	Flashing green/yellow	OFF	ON	ON
Device error	01	FF	6301	25345	CS FLASH	8040	Green ON	ON	OFF	ON
Flash format error	01	FF	6302	25346	FO FLASH	8040	Green ON	ON	OFF	ON
Parameter table invalid	01	FF	6320	25376	Invalid para	8010	Green ON	ON	OFF	ON
Open circuit	01	01 ... 04	7710	30480	Open circuit	8002	Green ON	ON	OFF	ON

Reset diagnostic messages (0019_{hex}: ResetDiag)

You can delete the diagnostics memory and acknowledge the diagnostic messages with this object.

0019 _{hex} : ResetDiag (Write)					
Subindex	Data type	Length in bytes	Meaning	Contents	
0	Unsigned 8	1	Reset diagnostics	00 _{hex}	All diagnostic messages approved
				02 _{hex}	Deletes and acknowledges all pending diagnostic messages that have not been read out
				06 _{hex}	Deletes and acknowledges all the diagnostic messages and allows no further diagnostic messages
				Other	Reserved

15.5 Objects for process data management

Index (hex)	Object name	Object type	Data type	A	L	Rights	Assignment
0024	ResetCode	Simple variable	Unsigned 16	4	2	R/W	Behavior during a bus reset
0025	PDIN	Var	Octet string	1	8	R	Input process data
0026	PDOOUT	Var	Octet string	1	8	R/W	Output process data
0027	GetExRight		Integer 8	1	1	R/W	Get exclusive process data write rights
002F	PDOOUT_Subst		Integer 16	4	2	R/W	Substitute value for the OUT process data

Behavior during a bus reset (0024_{hex}: ResetCode)

This object is used to parameterize the behavior of the outputs when a bus reset is detected.

0024 _{hex} : BusResetCode (Read, write)					
Subindex	Data type	Length in bytes	Meaning	Contents	Default value
0	Array	4 * 2	Behavior during a bus reset		

Element	Data type	Length in bytes	Meaning	Contents	Default value
1	Unsigned 16	2	Channel 1 reset code	0000 ... 0003 _{hex}	0002 _{hex}
:	:	:	:	:	:
4	Unsigned 16	2	Channel 4 reset code	0000 ... 0003 _{hex}	0002 _{hex}

Value range:

Code (hex)	Behavior
0000	Output of zero values (0 V/0 mA/4 mA) at output
0001	Output of final values (10 V/5 V/20 mA) at output
0002	Hold the last values
0003	Transfer the substitute values from the "Replace output process data" (002F _{hex}) object

Behavior of the outputs when the supply voltage fails

U _A	U _{Bus}	Behavior of the outputs
Available	Available	Nominal operation or see object 0024 _{hex}
Missing	Available	Outputs to 0 V/0 mA
Available	Missing	Outputs to 0 V/0 mA

Special features

- You can only access this object via subindex 0, i. e., you access the entire object.
- In the case of valid parameters, the object is stored permanently.

IN process data (0025_{hex}: PDIN)



In the case of Sercos, the IN process data is hidden and therefore unavailable.

You can read the IN process data of the module with this object.

The structure corresponds to the representation in the "Process data" section.

0025 _{hex} : PDIN (Read)			
Subindex	Data type	Length in bytes	Meaning
0	Octet string	8	Input process data

OUT process data (0026_{hex}: PDOOUT)

You can read or write the OUT process data of the module with this object.

The structure corresponds to the representation in the "Process data" section.

0026 _{hex} : PDOOUT (Read)			
Subindex	Data type	Length in bytes	Meaning
0	Octet string	8	Output process data

There are 2 bytes available for each channel, starting with channel 1.

Observe the notes in the section "Writing the analog values via the PDI channel".

Request exclusive write access (0027_{hex}: GetExRight)

This object allows you to determine which channel (process data channel or PDI channel) gets the rights for writing the outputs.

0027 _{hex} : GetExRight (read, write)					
Subindex	Data type	Length in bytes	Meaning	Contents	
0	Simple variable	1	Get exclusive process data write rights	00 _{hex}	Rights for writing output data over the PD channel (process data channel)
				01 _{hex}	Rights for writing output data via the PDI channel

All other values are invalid and will be acknowledged with an error.



Please note the following for your process:

The parameterization in object 0027_{hex} "Rights for writing the output data via the PDI channel" overwrites the OUT process data transmitted via the process data channel with the values from object 0026_{hex} PDOOUT. From now, the OUT process data can only be changed using the PDI object. Changes on the process data channel will have no effect.

If the value from the process data channel is to be used again, write access must be changed to "Rights for writing the output data via the PD channel (process data channel)" via the GetExRight object. After a power reset, the values transmitted via the process data channel are always valid.

Substitute value for the OUT process data (002F_{hex}: PDOOUT_Subst)

This object is used to parameterize the substitute values that are to be output at the analog outputs during a bus reset. However, option 0003 must have been selected in the “Behavior during bus reset” object (0024_{hex}).

In the case of valid parameters, the parameterization is stored in the module permanently.

After resetting, the module works with the last permanently stored data. Upon delivery, the module works with the default data (default settings).

002F _{hex} : PDOOUT_Subst (Read, write)			
Subindex	Data type	Length in bytes	Meaning
0	Array of Unsigned 16	4 * 2	Replace output process data

There are 2 bytes available for each channel, starting with channel 1.

The values are used in the parameterized format.

Example:

Channel 1: 1 V, channel 2: 2 V ... channel 4: 4 V, IB IL format

0B B8 17 70 23 28 2E E0

Special features

- You can only access this object via subindex 0, i. e., you access the entire object.
- In the case of valid parameters, the object is stored permanently.
- The parameterized values are compared with the selected output range. If the substitute value does not correspond to the output range, an error message is issued.

15.6 Objects for device management

Objects 0029_{hex}, 002A_{hex}, 002D_{hex}, and 002E_{hex} are available as of firmware 1.10.

Index (hex)	Object name	Object type	Data type	A	L	Rights	Meaning
001D	Password	Simple variable	Octet string	1	9	W	Password
0029	ParamSetWriteControl	Byte	Unsigned 8	1	1	R/W	Parameter set write control
002A	ConflictDictionary	Record		N	12	R	Conflict dictionary
002D	ResetParam	Simple variable	Unsigned 8	1	1	R/W	Reset parameterization
002E	Checksum	Simple variable	Unsigned 32	1	4	R	Checksum

Password (001D_{hex}: Password)

By entering the "Superuser" password you permit writing to the "Exclusiv right received" object. These rights are required to transmit process data over the PDI channel.

001D _{hex} : password (Write)			
Subindex	Data type	Length in bytes	Meaning
0	Simple variable	9	Password

Parameter record write control (0029_{hex}: ParamSetWriteControl)

This object is used to control block parameterization.

0029 _{hex} : ParameterSetWriteControl (read/write)				
Subindex	Data type	Length in bytes	Meaning	
0	Unsigned 8	1	Parameter record write control	
			00 _{hex}	Termination of block parameterization
			01 _{hex}	Initiation of block parameterization

Block parameterization serves to enable the joint transfer of interdependent parameters.

If you attempt to parameterize dependent parameters individually, this may result in the error message "Dependency of other parameter not taken into consideration". Block parameterization should be used in this case.

The plausibility check for the parameterization data is disabled during block parameterization, the data is only stored temporarily. However, the data length and subindex are checked.

The plausibility check is only performed when block parameterization is terminated with data item 00_{hex}.

If the check was completed with no errors, the temporarily stored parameterization data is applied and stored in the Flash memory.

If errors were detected in the temporarily stored parameterization data, the service is acknowledged negatively with 08, 00, 0040_{hex}.

The exact cause of the error can be read in object 002A_{hex}. The error codes are indicated by object 0080_{hex}.

Not all startup objects have to be written.

The following actions are carried out when the parameter contents are modified:

Write control changes from 00_{hex} to 01_{hex}: initiation of block parameterization

- Block parameterization is initiated
- Conflict dictionary is reset

Write control changes from 01_{hex} to 00_{hex}: termination of block parameterization

- Block parameterization is terminated
- Individual parameterization is active
- Parameterization is checked for compatibility

Parameters are compatible:

- The parameter contents are accepted.
- Write access to the write control parameter is acknowledged positively.

Parameters are not compatible:

- The old contents of all the parameters required for block parameterization remain in effect.
- The conflict dictionary is updated.
- Write access to the write control parameter is acknowledged negatively.

Conflict dictionary (002A_{hex}: ConflictDictionary)

This object contains the indices and error messages (additional code) for the parameters involved in the conflict.

002A _{hex} : ConflictDictionary (Read)			
Subindex	Data type	Length in bytes	Meaning
0		12	Conflict dictionary

Meaning	Length in bytes	Example	
Subslot	1	00	No subslot
Index	2	00 2F	PDOOUT_Subst
Subindex	1	02	Substitute value for OUT2
Parameter number	1	01	
Error code and class	1	80	
Additional error code	2	02 40	Substitute value for OUT2 outside the limit values

Reset parameterization (002D_{hex}: ResetParam)

This object is used to reset the module to the default settings.

To reset the module value 01_{hex} must be transferred during write access. Any other values are not permissible and will be acknowledged with an error.

Then the default settings of the channels are loaded and all the user-set parameters are reset.

Error code in the event of negative acknowledgment:

Code (hex)	Additional code (hex)	Meaning	Remedy
0801	0040	Dependent values were not taken into consideration.	Check the parameterization.

To use block parameterization without tools, proceed in the following sequence:

- Initiate block parameterization by writing the value 01_{hex} to object 0029_{hex}.
- Write the parameter table (ParaTable) to object 0080_{hex}.
- Write the substitute value behavior during a bus reset (ResetCode) to object 0024_{hex}.
- Write the substitute value for the OUT process data in the event of an error (PDOOUT_Subst) to object 002F_{hex}.
- Terminate block parameterization by writing the value 00_{hex} to object 0029_{hex}.

Checksum (002E_{hex}: Checksum)

The data of the startup objects is verified with this CRC32 checksum.

Checksum for the default setting: 6B F7 35 CF_{hex}

16 Application objects

Index (hex)	Object name	Object type	Data type	A	L	Rights	Assignment
0080	ParaTable	Array	Unsigned 16	6	6 * 2	R/W	Parameter table

16.1 Parameter table (0080_{hex}: ParaTable)

Parameterize the module using this object.

In the case of valid parameters, the parameterization is stored in the module permanently.

After resetting, the module works with the last permanently stored data. Upon delivery, the module works with the default data (default settings).

0080 _{hex} : ParaTable (read, write)				
Subindex	Data type	Length in bytes	Meaning	Default value
0	Array of Unsigned 16	6 * 2	Read/write all elements	See subindices
1	Unsigned 16	2	Parameterization of channel 1	0000 _{hex}
:	Unsigned 16	2	:	0000 _{hex}
4	Unsigned 16	2	Parameterization of channel 4	0000 _{hex}
5	Unsigned 16	2	Data format	0000 _{hex}
6	Unsigned 16	2	Reserved	0000 _{hex}

Parameterization channel 1 ... channel 4

Parameterization word

15	14	13	12	11	10	9	8	7	6	5	4	3	2	1	0
0	0	0	0	0	0	0	0	0	0	0	0	0	0	0	0

Output range

Output range

Output range	Code (bin)	Code (hex)
0 V ... 10 V (default)	0000	0
±10 V	0001	1
0 V ... 5 V	0010	2
±5 V	0011	3
0 mA ... 20 mA	0100	4
Reserved	0101	5
4 mA ... 20 mA	0110	6
Channel inactive	1111	F
Other	Reserved	

Data format

15	14	13	12	11	10	9	8	7	6	5	4	3	2	1	0
0	0	0	0	0	0	0	0	0	0	0	0	0	0	0	0

Data format

Data format	Code (bin)	Code (hex)
IB IL (default setting)	00	0
Reserved	01	1
S7-compatible	10	2
Reserved	11	3



Set all unused bits to 0.

17 Writing the analog values over the PDI channel

PDI = Parameters, Diagnostics and Information

The exclusive right must be changed first, if the analog values are not to be output via the process data, but via the PDI channel. To do this, proceed as follows.

- Write the ASCII string "Superuser" to the "Password" (001D_{hex}) object.
- Write the value 01_{hex} to the "Request exclusive write access" object (0027_{hex}).

You may now write to the "Output process data" (0026_{hex}) object.

18 Device descriptions

The device is described in the device description files.

The device descriptions for controllers from Phoenix Contact are included in PC Worx and the corresponding service packs.

The device description files for other systems are available for download at phoenixcontact.net/products in the download area of the bus coupler used.