



LC573010A, 573015A

4-bit Single Chip Microcontroller

Overview

LC573010A and LC573015A are CMOS 4-bit microcontroller featuring low-voltage operation and low power dissipation.

Both LC573010A and LC573015A incorporate a 4-bit parallel processing ALU, 1 K bytes/1.5 K bytes ROM, a 32 × 4-bit RAM, a 16-bit timer, and an infrared remote control transmission carrier output circuit.

Applications

- Remote controller
- Control of small measuring instruments

Features

- ROM : 1024 × 8 bits (LC573010A)
1536 × 8 bits (LC573015A)
- RAM : 32 × 4 bits
- Cycle time

Cycle time	System clock generator	Oscillation frequency	Supply voltage
17.6 μsec	Ceramic oscillation circuit	455 kHz	2.3 to 6.0 V

- Current drain
At normal operation

Current drain	System clock generator	Oscillation frequency	Supply voltage
150 μA typ	CR oscillation	455 kHz	3.0 V
400 μA typ	CR oscillation	455 kHz	5.0 V

HALT mode

Current drain	System clock generator	Oscillation frequency	Supply voltage
80 μA typ	CR oscillation	455 kHz	3.0 V
300 μA typ	CR oscillation	455 kHz	5.0 V

HOLD mode

Leakage current	Condition	Oscillation frequency	Supply voltage
0.1 μA typ	When CR oscillation is at STOP mode	455 kHz	5.0 V

Package Dimensions

unit: mm

3112-MFD24S

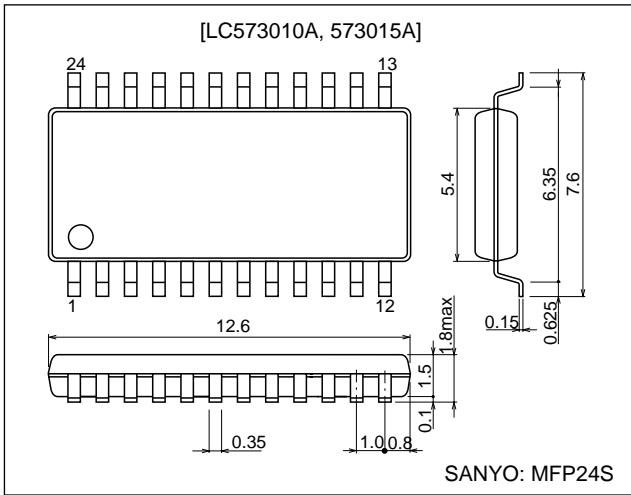

Pin Assignment

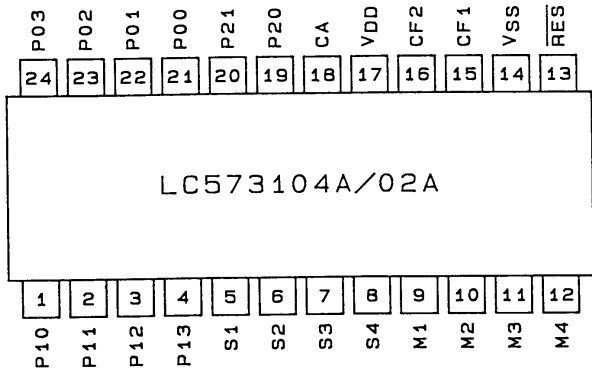

A00621

■ Any and all SANYO products described or contained herein do not have specifications that can handle applications that require extremely high levels of reliability, such as life-support systems, aircraft's control systems, or other applications whose failure can be reasonably expected to result in serious physical and/or material damage. Consult with your SANYO representative nearest you before using any SANYO products described or contained herein in such applications.

■ SANYO assumes no responsibility for equipment failures that result from using products at values that exceed, even momentarily, rated values (such as maximum ratings, operating condition ranges, or other parameters) listed in products specifications of any and all SANYO products described or contained herein.

- Port
 - Input port (S port, M port) : 2-port (8 pins) [Key scan input port]
 - Input/Output port : 3-port (10 pins)
 - P0 port, P1 port 2-port (8 pins) [Key scan output port]
 - P2 port 1-port (2 pins) [Key scan expansion port]
[LED direct drivable port]
- Infrared remote control carrier generation circuit
 - Software-controllable remote control carrier output ON/OFF.
 - Software-controllable carrier frequency and duty ratio.
<38 kHz-1/3 duty, 38 kHz-1/2 duty, 57 kHz-1/2 duty>
(When fixed carrier signal is output, it is specified by mask option)
 - 1 kHz to 200 kHz infrared remote control transmission carrier frequency.
(When carrier output is selected by timer at mask option, and when 455 kHz CR oscillator is used)
 - Infrared carrier output-dedicated terminal built-in (CA terminal).
 - 108 ms HALT-mode cancel signal output.
- Timer
 - 16-bit software-controllable timer
Timer input clock : Ceramic (CR) oscillation frequency (455 kHz)
 - 108 ms HALT release request signal generation timer (Free running timer)
 - Watchdog timer (changed over between USED/UNUSED by mask option)
- Sub-routine stack level
 - 2 levels
- Oscillation circuit
 - Ceramic (CR) oscillation circuit : 455 kHz (for System clock generation), feedback resistor built-in.
- Standby function
 - HALT mode
HALT mode used to reduce current drain.
HALT mode suspends program execution.
Following shows how to release the HALT mode.
 - (A) System reset
 - (B) HALT mode release request signal
 - HOLD mode
HOLD mode stops ceramic resonator (CR). The HOLD mode can be released in two ways.
 - (A) System reset
 - (B) Apply H level input to S port pin or M port pin. (However, it is necessary to set S port or M port HOLD mode release permission flag beforehand.)
- Form of shipment
 - MFP-24S (1.0 mm pitch)

Note : When dipping in solder to mount the MFP package on board, contact SANYO for instructions.

The Application Development System for the LC573100 Series.

Manual

- (1) Users Manual : LC573100 Series Users Manual
- (2) Development Tool Manual : LC573100 Series Development Tool Manual

Development Tools

- Tools for application development of the LC573100 Series
 - (1) Personal computer (MS-DOS based)
 - (2) Cross assembler (LC573100. EXE)
 - (3) Mask option generator (SU573100. EXE)
- Tools to evaluate application development of the LC573100 Series.
 - (1) EVA chip (LC5797)

Note : 1 As RAM capacity differs between EVA chip (LC5797) and the LC573100 Series, always check before programming and debugging.

LC573010A/LC573015S : 64 × 4 bits

LC5797 : 256 × 4 bits

Note : 2 Always keep the DPH value in mind when programming. Only DPH '0' to '3' may be used as the RAM address.

If DPH other than '0' to '3' is used as RAM address when programming, SANYO will not be liable for any trouble caused.

(2) EVA chip board (TB5730)

Note : The application evaluation board is the evaluation board made by the user.

(3) Evaluation board [EVA420 (Monitor ROM : ER-573000)]

(4) Display and mask option data control board [DCB-1A (REV3.6)]

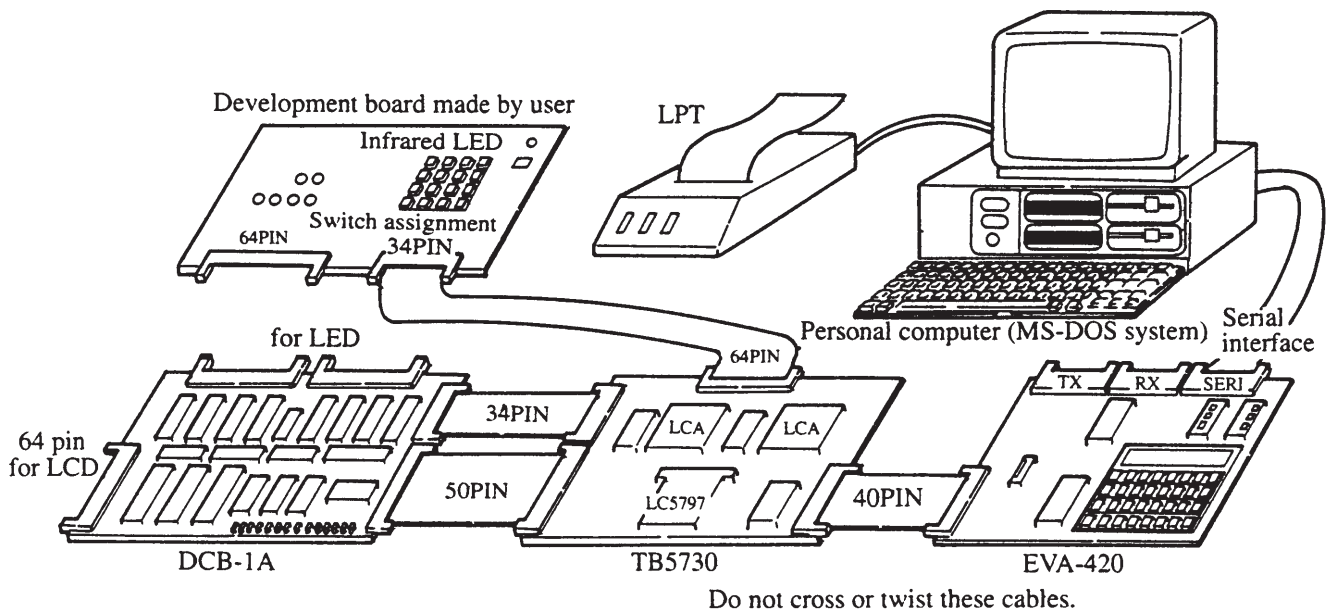

Development Support System Outline

Block Diagram

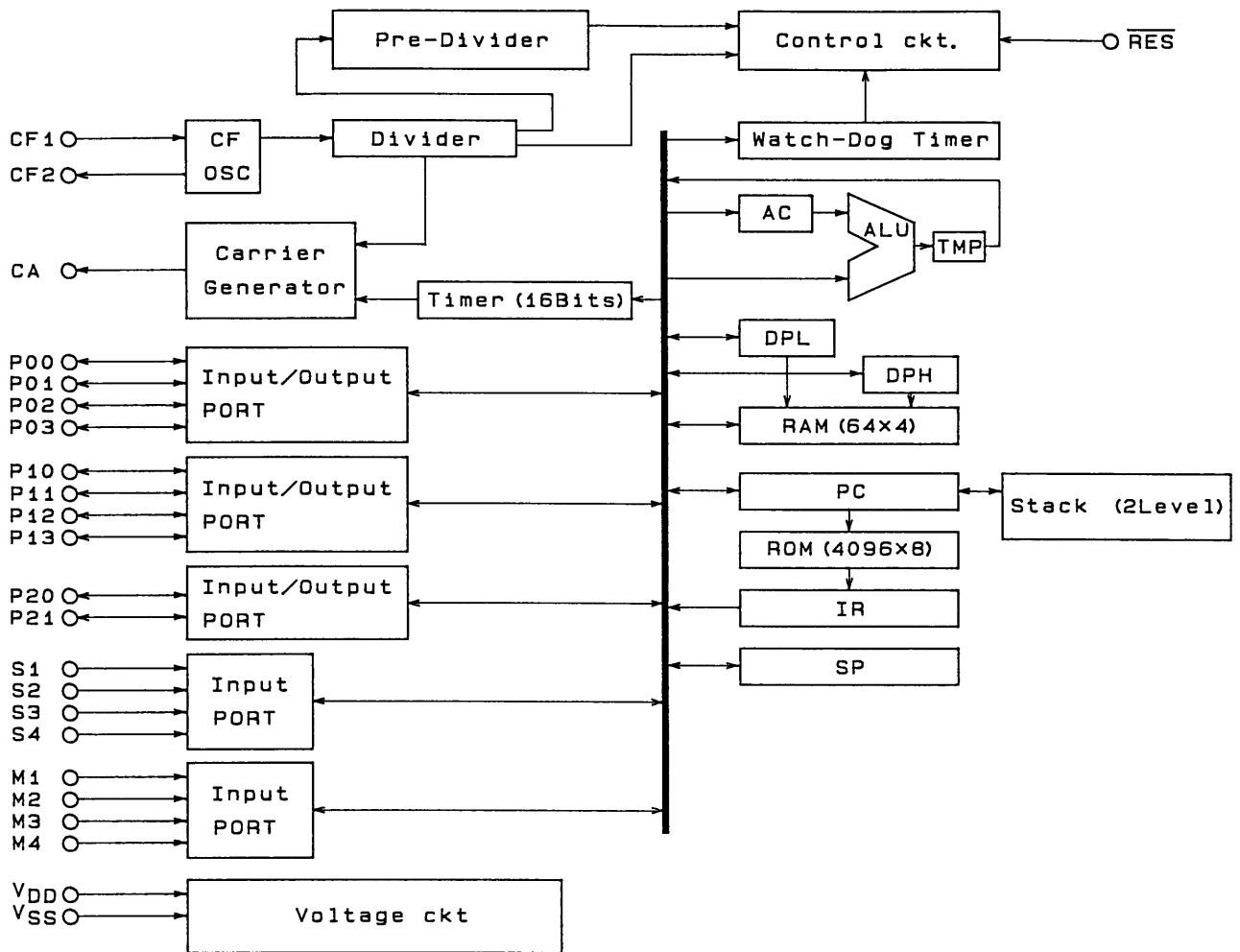

A00622

LC573010A, 573015A

Pin Assignment

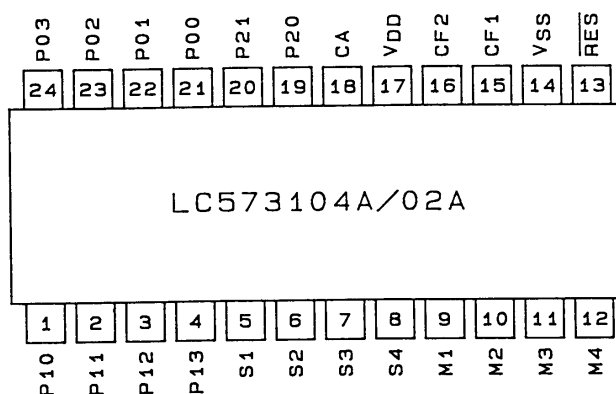

A00621

Pin Functions

MFP24S Pin no.	Pin name	Input/ output	Function description	Option	Reset status
17	V _{DD}	–	Supply voltage. See Figure 1.		
14	V _{SS}	–	Ground. See Figure 1.		
15	CF1	Input	Used for system clock oscillation • 455 kHz ceramic resonator is connected between CF1 and CF2 for oscillation.		
16	CF2	Output	• Stops oscillation when receiving CR oscillation stop command.		
5 6 7 8	S1 S2 S3 S4	Input	Input port S. • LSI system is reset by charging V _{DD} to S1 to S4 simultaneously. (Mask option) • Data is loaded in accumulator.	(1) Low level HOLD Tr YES/NO (2) Reset by S1 to S4.	• Pull-down resistor ON • Reset signal ENABLE
9 10 11 12	M1 M2 M3 M4	Input	Input port M. Data loaded in accumulator	Low level HOLD Tr YES/NO	• Pull-down resistor ON
21 22 23 24	P00 P01 P02 P03	Input/ output	Input/output port • Data loaded in accumulator. • Output pin to output data from accumulator. (P-ch open drain output)		
1 2 3 4	P10 P11 P12 P13	Input/ output	Input/output port • Data loaded in accumulator. • Output pin to output data from accumulator. (P-ch open drain output)		
19 20	P20 P21	Input/ output	Input/output port • Data loaded in accumulator. • Output pin to output data from accumulator. (P-ch open drain output) • LED direct drivable pin		
18	CA	Output	Remote control carrier output.	Fixed carrier output/carrier output by timer	• At reset low level • At fixed carrier output 38 kHz- 1/3 duty
13	RES	Input	Reset input. Internal pull-up resistor.		

Supply Connections

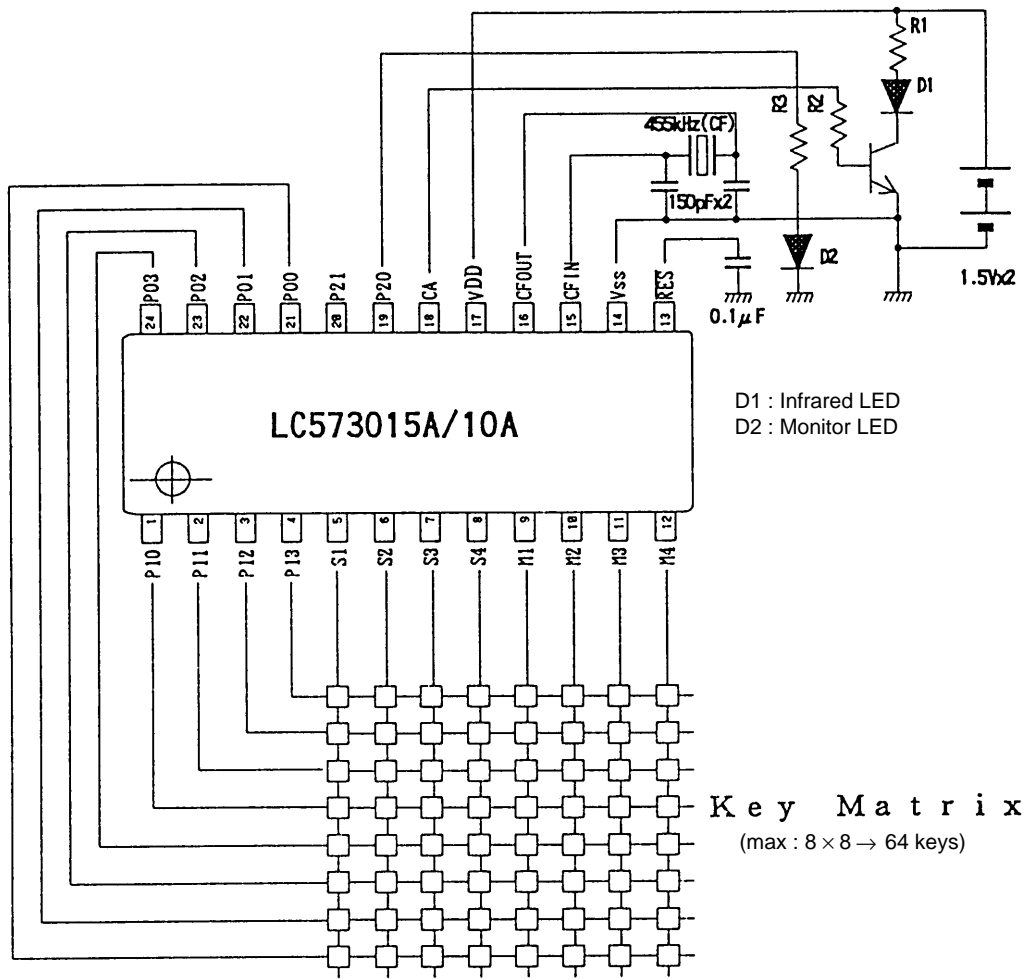
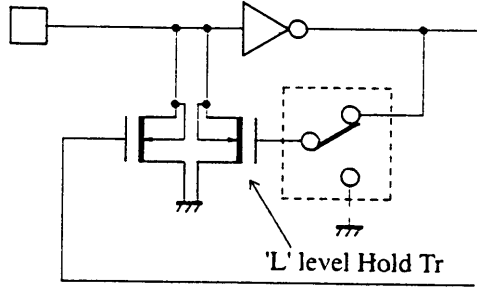

Figure 1 Supply Connections

Mask Option

Input port option

Option	Circuit	Remarks
Low level hold Tr selection	 <p style="text-align: center;">'L' level Hold Tr</p> <p style="text-align: right;">A00433</p>	Next port switches over in sequence. • S1 to S4, M1 to M4 Input signal level Hold Tr selection • Low level hold Tr used. • Low level hold Tr not used.

Reset signal option by S port

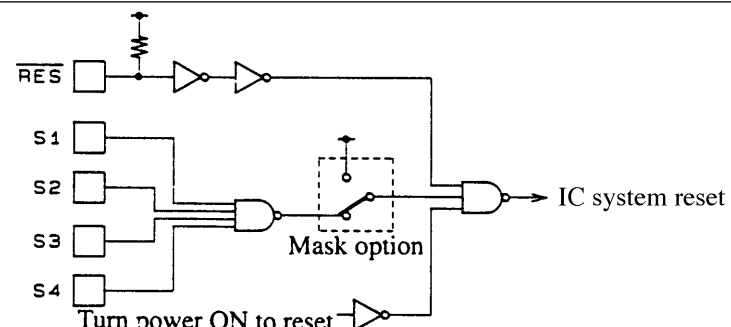
Option	Circuit	Remarks
Resetting IC by S port	 <p style="text-align: center;">Mask option</p> <p style="text-align: center;">Turn power ON to reset</p>	Selects signal for resetting IC system by simultaneously charging High level to S1 to S4. • Allow • Prohibit

Carrier standard clock generation circuit option for remote control

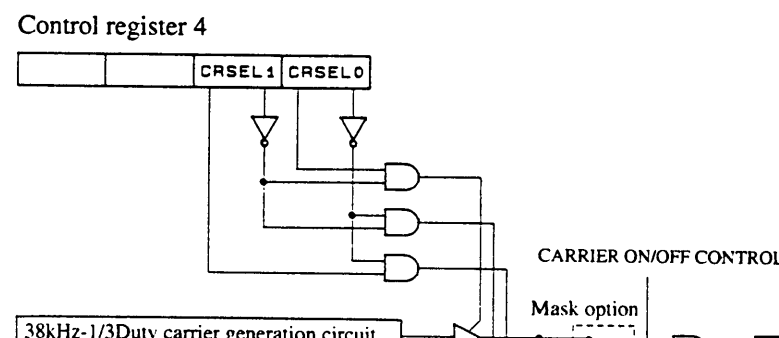
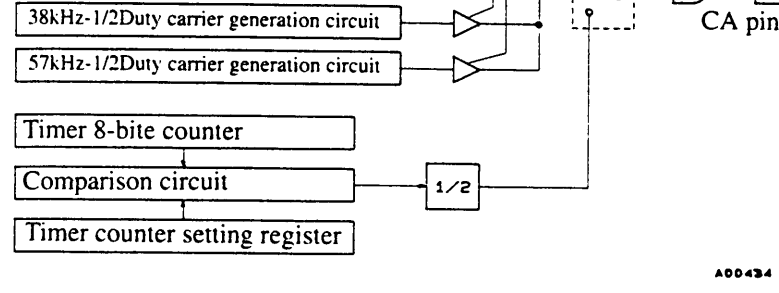
Option	Circuit	Remarks
38/57 kHz	 <p style="text-align: center;">Mask option</p> <p style="text-align: center;">CARRIER ON/OFF CONTROL</p> <p style="text-align: center;">CA pin</p>	Software-controllable carrier frequency and duty. • Following carrier frequency and duty may be selected by setting control register 4. (1) 38 kHz-1/3 duty (2) 38 kHz-1/2 duty (3) 57 kHz-1/2 duty
Timer 8-bit overflow	 <p style="text-align: center;">Mask option</p>	Timer 8-bit overflow signal generates carrier signal for infrared remote control. Fixed 1/2 duty

LC573010A, 573015A

Watchdog timer circuit option

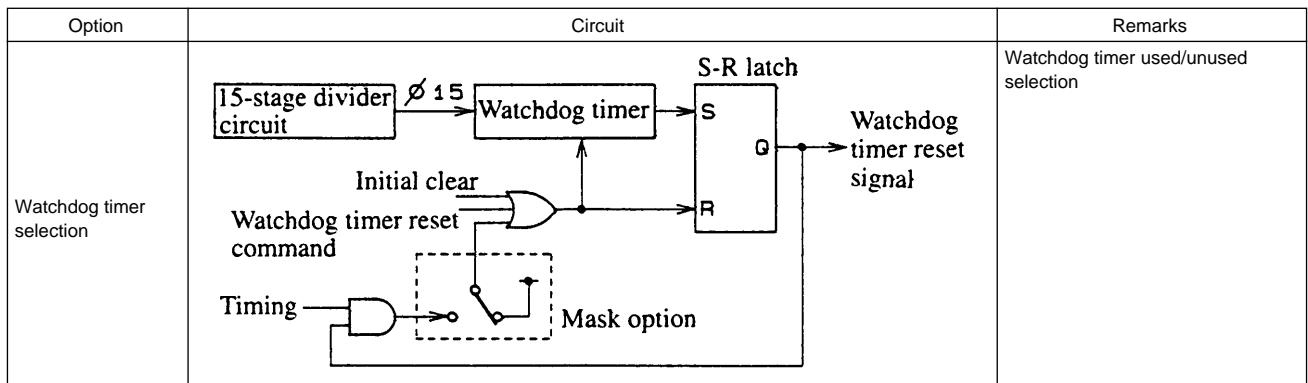

Specifications

Absolute Maximum Ratings at $T_a = \pm 25 + 2^\circ\text{C}$, $V_{SS} = 0\text{ V}$

Parameter	Symbol	Conditions	Rating	Unit
Supply voltage range	V_{DD}		-0.3 to +7.0	V
Input voltage range	V_{IN}	S1 to S4, M1 to M4, \overline{RES} , P00 to P03, P10 to P13, P20, P21, CF1 (P00 to P03, P10 to P13, P20, P21 are input mode)	-0.3 to $V_{DD} + 0.3$	V
Output voltage range	V_{OUT}	CA, P00 to P03, P10 to P13, P20, P21, CF2 (P00 to P03, P10 to P13, P20, P21 are output mode)	-0.3 to $V_{DD} + 0.3$	V
Output current (Per 1 pin)	I_{OUT1}	CA (per 1 pin)	25	mA
	I_{OUT2}	P00 to P03, P10 to P13 (per 1 pin)	500	μA
	I_{OUT3}	P20, P21 (per 1 pin)	10	mA
	I_{OUT4}	Output pins other than listed above (per 1 pin)	500	μA
Total output current of all pins except CA	I_{ALL}	All pins totalled (except for CA pin)	25	mA
Operating temperature range	T_{opr}		-30 to +70	$^\circ\text{C}$
Storage temperature range	T_{stg}		-40 to +125	$^\circ\text{C}$

LC573010A, 573015A

Recommended Operating Range at $T_a = -30$ to $+70^\circ\text{C}$, $V_{SS} = 0\text{ V}$

Parameter	Symbol	Conditions	Ratings			Unit
			min	typ	max	
Supply voltage	V_{DD}		2.3		6.0	V
Input high level voltage	V_{IH1}	S1 to S4, M1 to M4, P00 to P03, P10 to P13, P20, P21 (P0, P1, P2 ports are input mode)	$0.7V_{DD}$		V_{DD}	V
Input low level voltage	V_{IL1}		V_{SS}		$0.3V_{DD}$	V
Input high level voltage	V_{IH2}	\overline{RES}	$0.75V_{DD}$		V_{DD}	V
Input low level voltage	V_{IL2}		0		$0.25V_{DD}$	V
Operation frequency	f_{OPG}	At CR oscillation, Figure.2	380	455	500	kHz

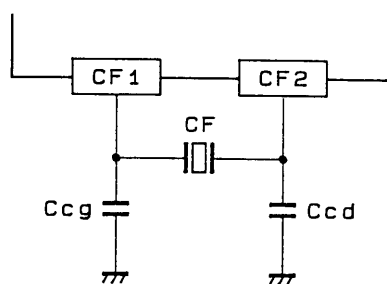

A00436

Figure.2 : CR Oscillation Circuit

LC573010A, 573015A

Electrical Characteristics at $T_a = -30$ to $+70^\circ\text{C}$, $V_{SS} = 0\text{ V}$

Parameter	Symbol	Conditions	Ratings			Unit	
			min	typ	max		
Input impedance	R_{IN1A}	$V_{DD} = 2.9\text{ V}$, $V_{IL} = 0.4\text{ V}$, S1 to S4, M1 to M4: Low level hold T_r , Figure 3	150	300	1000	$k\Omega$	
	R_{IN1B}	$V_{DD} = 2.9\text{ V}$, $V_{IL} = 0.4\text{ V}$, S1 to S4, M1 to M4: Low level pull-down T_r , Figure 3	30	50	100	$k\Omega$	
	R_{IN2}	$V_{DD} = 2.9\text{ V}$, $V_{IH} = V_{DD}$, \overline{RES}	10		300	$k\Omega$	
Output high level voltage	V_{OH1}	$V_{DD} = 2.9\text{ V}$, $I_{OH} = -450\ \mu\text{A}$, P00 to P03, P10 to P13	$V_{DD} - 0.45$			V	
Output off-leak current	$ I_{OFF} $	$V_{DD} = 2.9\text{ V}$, P00 to P03, P10 to P13	$V_{IN} = V_{SS}$		1.0	μA	
	$ I_{OFF} $		$V_{IN} = V_{DD}$		1.0	μA	
Output high level voltage	V_{OH2}	$V_{DD} = 2.9\text{ V}$, $I_{OH} = -10\text{ mA}$, P20, P21	$V_{DD} - 1.5$			V	
Output off-leak current	$ I_{OFF} $	$V_{DD} = 2.9\text{ V}$, P20, P21	$V_{IN} = V_{SS}$		1.0	μA	
	$ I_{OFF} $		$V_{IN} = V_{DD}$		1.0	μA	
Output current (H)	I_{OH1}	$V_{DD} = 3.0\text{ V}$, $V_{OH} = V_{DD} - 1.5\text{ V}$, CA		-12	-6	mA	
Output current (L)	I_{OL1}	$V_{DD} = 3.0\text{ V}$, $V_{OH} = 0.9\text{ V}$, CA	2	5		mA	
HALT-mode supply current	I_{DD1}	$V_{DD} = 3.0\text{ V}$, 455 kHz CR oscillation, $C_{cd} = C_{cg} = 150\text{ pF}$, $T_a \leq 50^\circ\text{C}$, Figure 5		80	300	μA	
Operating Current	I_{DD2}	$V_{DD} = 3.0\text{ V}$, 455 kHz CR oscillation, $C_{cd} = C_{cg} = 150\text{ pF}$, $T_a \leq 50^\circ\text{C}$, Figure 5		150	500	μA	
Supply leak current 1	I_{LEAK1}	$V_{DD} = 3.0\text{ V}$	$T_a = 25^\circ\text{C}$		0.2	1	μA
Supply leak current 2	I_{LEAK2}		$T_a = 50^\circ\text{C}$		1	5	μA
Oscillator start-up voltage	V_{ST}	Ccd = Ccg = 150 pF, 455 kHz CR oscillation, Figure 4			2.3	V	
Oscillator sustaining voltage	V_{SUS}		2.0			V	
Oscillator start-up time	t_{ST}	$V_{DD} = 2.3\text{ V}$, $C_{cd} = C_{cg} = 150\text{ pF}$, 455 kHz CR oscillation, Figure 4			30	ms	

Recommended Oscillators

Oscillator	Manufacturer	Part number	Ccg	Ccd
455 kHz ceramic oscillator	Kyocera	KRB-455BK/Y	150 pF	150 pF
	Murata	CSB455E	150 pF	150 pF
	Fuji Ceramics	POE-455	150 pF	150 pF

LC573010A, 573015A

Electrical Characteristics at Ta = -30 to +70°C, VSS = 0 V

Parameter	Symbol	Condition	Ratings			Unit	
			min	typ	max		
Input impedance	R _{IN1A}	V _{DD} = 5.0 V, V _{IL} = 0.4 V, S1 to S4, M1 to M4: Low level hold Tr, Figure 3	70	200	300	kΩ	
	R _{IN1B}	V _{DD} = 5.0 V, S1 to S4, M1 to M4: Low level pull-down Tr, Figure 3	30	50	100	kΩ	
	R _{IN2}	V _{DD} = 5.0 V, $\overline{\text{RES}}$	10		300	kΩ	
Output high level voltage	V _{OH1}	V _{DD} = 5.0 V, I _{OH} = -750 μA, P00 to P03, P10 to P13	V _{DD} -0.75			V	
Output off-leak current	I _{OFF}	V _{DD} = 5.0 V, P00 to P03, P10 to P13	V _{IN} = V _{SS}		1.0	μA	
	I _{OFF}		V _{IN} = V _{DD}		1.0	μA	
Output high level voltage	V _{OH2}	V _{DD} = 5.0 V, I _{OH} = -10 mA, P20, P21	V _{DD} -0.5			V	
Output off-leak current	I _{OFF}	V _{DD} = 5.0 V, P20, P21	V _{IN} = V _{SS}		1.0	μA	
	I _{OFF}		V _{IN} = V _{DD}		1.0	μA	
Output current (H)	I _{OH1}	V _{DD} = 5.0 V, V _{OH} = V _{DD} - 2.5 V, CA	10	20		mA	
Output current (L)	I _{OL1}	V _{DD} = 5.0 V, V _{OL} = 0.9 V, CA	2			mA	
HALT-mode supply current	I _{DD1}	V _{DD} = 5.0 V, 455 kHz CR oscillation, Ccd = Ccg = 150 pF, Ta ≤ 50°C, Figure 5		300	400	μA	
Operating current	I _{DD2}	V _{DD} = 5.0 V, 455 kHz CR oscillation Ccd = Ccg = 150 pF, Ta ≤ 50°C, Figure 5		400	500	μA	
Supply leak current 1	I _{LEAK1}	V _{DD} = 5.0 V	Ta = 25°C		0.2	1	μA
Supply leak current 2	I _{LEAK2}		Ta = 50°C		1	5	μA
Oscillator start-up voltage	V _{ST}	Ccd = Ccg = 150 pF, 455 kHz CR oscillation, Figure 4				2.3	V
Oscillator sustaining voltage	V _{SUS}		2.0				V
Oscillator start-up time	t _{ST}	V _{DD} = 2.3 V, Ccd = Ccg = 150 pF, 455 kHz CR oscillation, Figure 4				30	ms

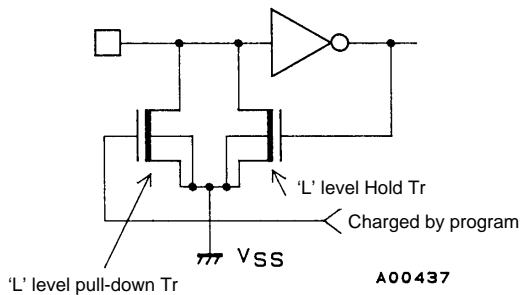

Figure 3 : S1 to S4, M1 to M4 Input Structure

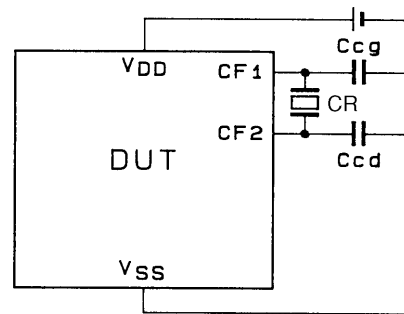

Figure4 : Oscillator Start-Up Voltage, Oscillator Sustaining Voltage, and Oscillator Start-Up Time Measuring Circuit

Note : CR is 455 kHz, S-PORT: M-PORT: Input Pull-down transistor is on. $\overline{\text{RES}}$ terminal has resistor built-in and is open. I/O-port is set at output mode and data is high.

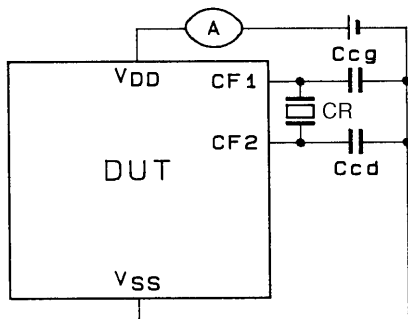

Figure 5 : Supply Current Measuring Circuit

- Specifications of any and all SANYO products described or contained herein stipulate the performance, characteristics, and functions of the described products in the independent state, and are not guarantees of the performance, characteristics, and functions of the described products as mounted in the customer's products or equipment. To verify symptoms and states that cannot be evaluated in an independent device, the customer should always evaluate and test devices mounted in the customer's products or equipment.
- SANYO Electric Co., Ltd. strives to supply high-quality high-reliability products. However, any and all semiconductor products fail with some probability. It is possible that these probabilistic failures could give rise to accidents or events that could endanger human lives, that could give rise to smoke or fire, or that could cause damage to other property. When designing equipment, adopt safety measures so that these kinds of accidents or events cannot occur. Such measures include but are not limited to protective circuits and error prevention circuits for safe design, redundant design, and structural design.
- In the event that any or all SANYO products (including technical data, services) described or contained herein are controlled under any of applicable local export control laws and regulations, such products must not be exported without obtaining the export license from the authorities concerned in accordance with the above law.
- No part of this publication may be reproduced or transmitted in any form or by any means, electronic or mechanical, including photocopying and recording, or any information storage or retrieval system, or otherwise, without the prior written permission of SANYO Electric Co., Ltd.
- Any and all information described or contained herein are subject to change without notice due to product/technology improvement, etc. When designing equipment, refer to the "Delivery Specification" for the SANYO product that you intend to use.
- Information (including circuit diagrams and circuit parameters) herein is for example only; it is not guaranteed for volume production. SANYO believes information herein is accurate and reliable, but no guarantees are made or implied regarding its use or any infringements of intellectual property rights or other rights of third parties.

This catalog provides information as of December, 1998. Specifications and information herein are subject to change without notice.