

# THC63LVDF84C

## 24bit COLOR LVDS RECEIVER (Falling Edge Clock)

### General Description

The THC63LVDF84C receiver supports wide temperature range as -40 to +85°C, and wide frequency range as 8 to 112MHz.

The THC63LVDF84C converts the four LVDS data streams back into 24bits of CMOS/TTL data with falling edge clock. At a transmit clock frequency of 112MHz, 24bits of RGB data and 4bits of timing and control data (HSYNC, VSYNC, DE, etc.) are transmitted at an effective rate of 3.1Gbps.

### Application

- Medium and Small Size Panel
- Security Camera / Industrial Camera
- Multi Function Printer
- Industrial Equipment
- Medical Equipment Monitor

### Features

- 1:7 LVDS to CMOS De-Serializer
- Operating Temperature Range : -40 to +85°C
- No Special Start-up Sequence Required
- Spread Spectrum Clocking Tolerant up to 100kHz Frequency Modulation and +/-2.5% Deviations
- Dot Clock Range: 8 to 112MHz Suited for VGA, SVGA, XGA, WXGA, and SXGA
- 56pin TSSOP Package
- PLL requires no external components
- Power Down Mode
- Falling Edge Clock
- EU RoHS Compliant

### Block Diagram

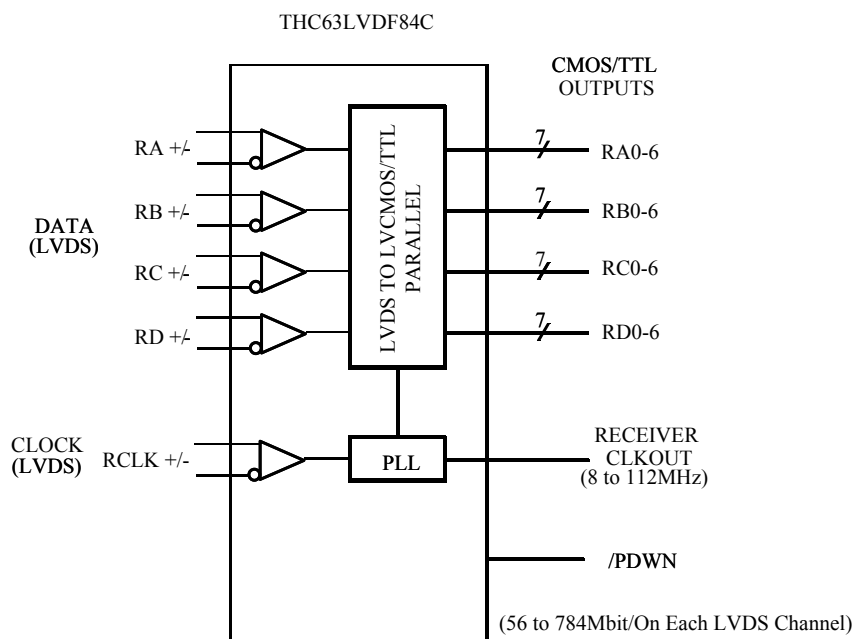

Figure 1. Block Diagram

Pin Diagram

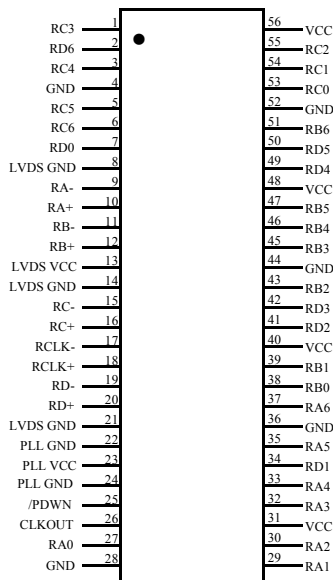

Figure 2. Pin Diagram

Pin Description

Pin Name	Pin #	Direction	Type	Description
RA+, RA-	10, 9	Input	LVDS	LVDS Data Inputs
RB+, RB-	12, 11			
RC+, RC-	16, 15			
RD+, RD-	20, 19			
RCLK+, RCLK-	18, 17	Output	CMOS / TTL	LVDS Clock Inputs
RA0 ~ RA6	27, 29, 30, 32, 33, 35, 37			Pixel Data Outputs
RB0 ~ RB6	38, 39, 43, 45, 46, 47, 51			
RC0 ~ RC6	53, 54, 55, 1, 3, 5, 6			
RD0 ~ RD6	7, 34, 41, 42, 49, 50, 2			
CLKOUT	26	Pixel Clock Output		
/PDWN	25	Input	-	H : Normal Operation L : Power Down (all outputs are pulled to ground)
VCC	31, 40, 48, 56	Power	-	Power Supply Pins for TTL outputs and digital circuitry
GND	4, 28, 36, 44, 52			Ground Pins for TTL outputs and digital circuitry
LVDS VCC	13			Power Supply Pins for LVDS inputs
LVDS GND	8, 14, 21			Ground Pins for LVDS inputs
PLL VCC	23			Power Supply Pins for PLL circuitry
PLL GND	22, 24			Ground Pins for PLL circuitry

Table 1. Pin Description

**Absolute Maximum Ratings**

Parameter	Min	Max	Unit
Supply Voltage (VCC)	-0.3	+4.0	V
CMOS/TTL Input Voltage	-0.3	VCC + 0.3	V
CMOS/TTL Output Voltage	-0.3	VCC + 0.3	V
LVDS Input Pin	-0.3	VCC + 0.3	V
Junction Temperature	-	+125	°C
Storage Temperature	-55	+150	°C
Reflow Peak Temperature	-	+260	°C
Reflow Peak Temperature Time	-	10	sec
Maximum Power Dissipation @+25°C	-	1.9	W

**Table 2. Absolute Maximum Ratings**

**Recommended Operating Conditions**

Symbol	Parameter	Min	Typ	Max	Unit
-	All Supply Voltage	3.0	-	3.6	V
Ta	Operating Ambient Temperature	-40	+25	+85	°C
-	Clock Frequency	8	-	112	MHz

**Table 3. Recommended Operating Conditions**

“Absolute Maximum Ratings” are those values beyond which the safety of the device can not be guaranteed. They are not meant to imply that the device should be operated at these limits. The tables of “Electrical Characteristics Table4, 5, 6, 7” specify conditions for device operation.

“Absolute Maximum Rating” value also includes behavior of overshooting and undershooting.

**Equivalent LVDS Input Schematic Diagram**

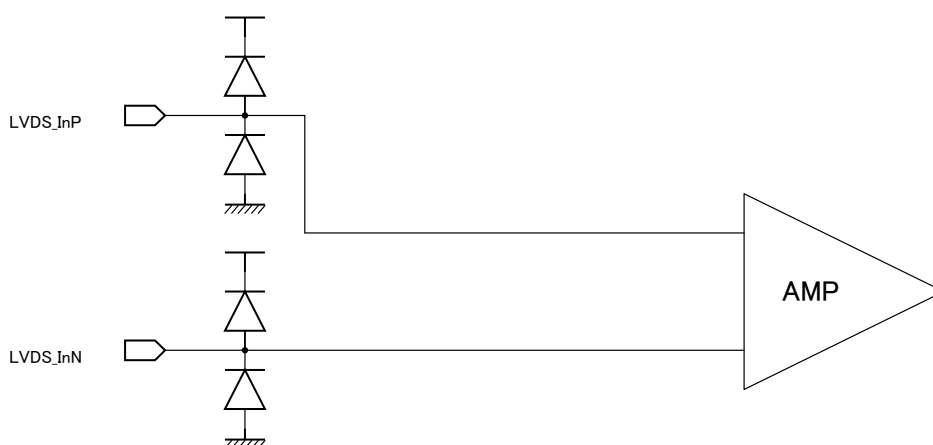

**Figure 3. LVDS Input Schematic Diagram**

**Power Consumption**

Over recommended operating supply and temperature range unless otherwise specified

Symbol	Parameter	Conditions	Typ*	Max	Unit
I <sub>RCCG</sub>	LVDS Receiver Operating Current Gray Scale Pattern 16 (Fig.4)	CL=8pF, f=65MHz, VCC=3.3V	55	70	mA
		CL=8pF, f=112MHz, VCC=3.3V	90	110	mA
I <sub>RCCW</sub>	LVDS Receiver Operating Current Worst Case Pattern (Fig.5)	CL=8pF, f=65MHz, VCC=3.3V	90	110	mA
		CL=8pF, f=112MHz, VCC=3.3V	130	160	mA
I <sub>RCCS</sub>	LVDS Receiver Power Down Current	/PDWN=L	-	500	μA

\*Typ values are at the conditions of Ta = +25°C

**Table 4. Power Consumption**

**16 Grayscale Pattern**

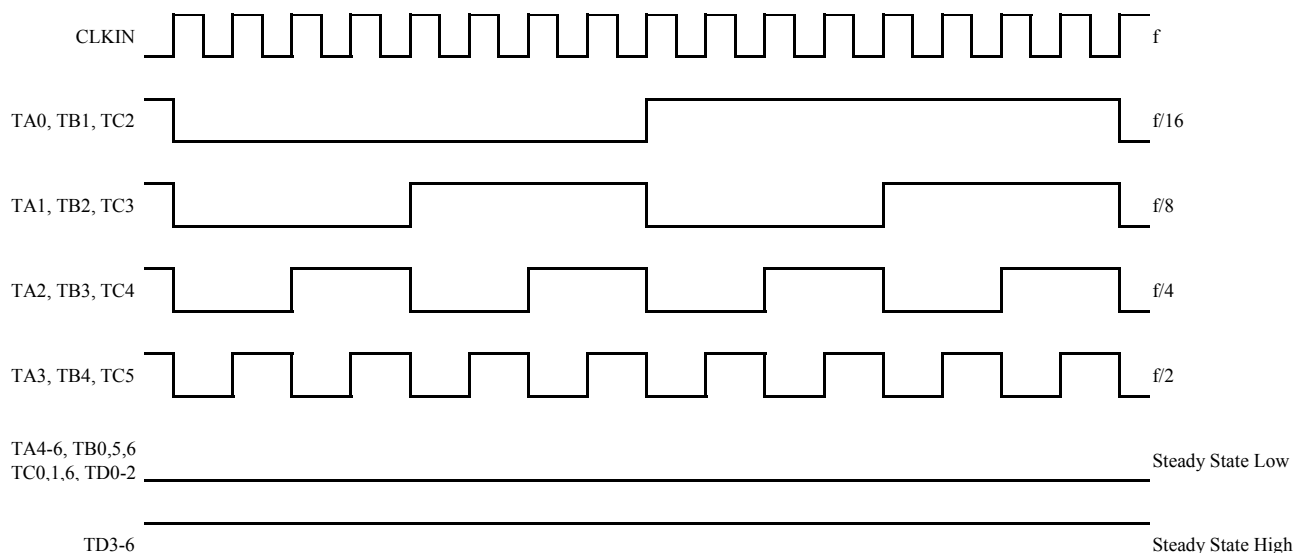

**Figure 4. 16 Grayscale Pattern**

**Worst Case Pattern**

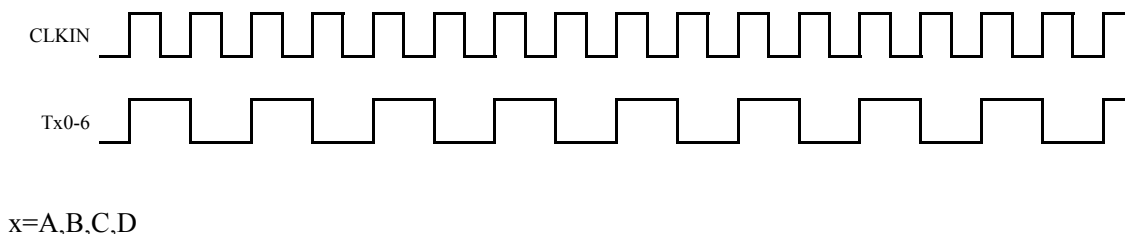

**Figure 5. Worst Case Pattern**

Electrical Characteristics

**CMOS/TTL DC Specifications**

Over recommended operating supply and temperature range unless otherwise specified

Symbol	Parameter	Conditions	Min	Typ	Max	Unit
V <sub>IH</sub>	High Level Input Voltage	-	2.0	-	VCC	V
V <sub>IL</sub>	Low Level Input Voltage	-	GND	-	0.8	V
V <sub>OH</sub>	High Level Output Voltage	I <sub>OH</sub> = -4mA (Data) I <sub>OH</sub> = -8mA (Clock)	2.4	-	-	V
V <sub>OL</sub>	Low Level Output Voltage	I <sub>OL</sub> = 4mA (Data) I <sub>OL</sub> = 8mA (Clock)	-	-	0.4	V
I <sub>IN</sub>	Input Current	GND ≤ V <sub>IN</sub> ≤ VCC	-	-	±10	µA

**Table 5. CMOS/TTL DC Specifications**

**LVDS Receiver DC Specifications**

Over recommended operating supply and temperature range unless otherwise specified

Symbol	Parameter	Conditions	Min	Typ*	Max	Unit
V <sub>TH</sub>	Differential Input High Threshold	RL=100Ω, VIC=+1.2V	-	-	100	mV
V <sub>TL</sub>	Differential Input Low Threshold		-100	-	-	mV
I <sub>IN</sub>	Input Current	V <sub>IN</sub> = +2.4 / 0V VCC = 3.6V	-	-	±30	µA

**Table 6. LVDS Transmitter DC Specifications**

### CMOS/TTL & LVDS Receiver AC Specifications

Over recommended operating supply and temperature range unless otherwise specified

Symbol	Parameter	Min	Typ*	Max	Unit	
$t_{RCP}$	CLKOUT Transition Time	8.92	T	125	ns	
$t_{RCH}$	CLKOUT High Time	-	T/2	-	ns	
$t_{RCL}$	CLKOUT Low Time	-	T/2	-	ns	
$t_{RCD}$	RCLK IN to CLKOUT +/- Delay	-	(3/14+3)T	-	ns	
$t_{RS}$	CMOS/TTL Data Setup to CLKOUT	0.35T - 0.3	-	-	ns	
$t_{RH}$	CMOS/TTL Data Hold from CLKOUT	0.45T - 1.6	-	-	ns	
$t_{TLH}$	CMOS/TTL Low to High Transition Time	-	0.7	1.0	ns	
$t_{THL}$	CMOS/TTL High to Low Transition Time	-	0.7	1.0	ns	
$t_{SK}$	Receiver Skew Margin	f=65MHz	-0.55	-	0.55	ns
		f=112MHz	-0.25	-	0.25	
$t_{RIP1}$	Input Data Position0	- $t_{SK}$	0.0	+ $t_{SK}$	ns	
$t_{RIP0}$	Input Data Position1	T/7- $t_{SK}$	T/7	T/7+ $t_{SK}$	ns	
$t_{RIP6}$	Input Data Position2	2T/7- $t_{SK}$	2T/7	2T/7+ $t_{SK}$	ns	
$t_{RIP5}$	Input Data Position3	3T/7- $t_{SK}$	3T/7	3T/7+ $t_{SK}$	ns	
$t_{RIP4}$	Input Data Position4	4T/7- $t_{SK}$	4T/7	4T/7+ $t_{SK}$	ns	
$t_{RIP3}$	Input Data Position5	5T/7- $t_{SK}$	5T/7	5T/7+ $t_{SK}$	ns	
$t_{RIP2}$	Input Data Position6	6T/7- $t_{SK}$	6T/7	6T/7+ $t_{SK}$	ns	
$t_{RPLL}$	Phase Lock Loop Set	-	-	10.0	ms	

\*Typ values are at the conditions of VCC=3.3V and Ta = +25°C

**Table 7. CMOS/TTL & LVDS Transmitter AC Specifications**

#### CMOS/TTL Output

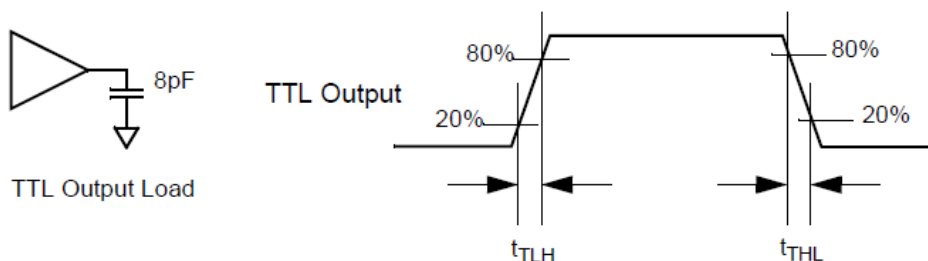

**Figure 6. CLKIN Transmission Time**

AC Timing Diagrams

LVDS Input Data Position

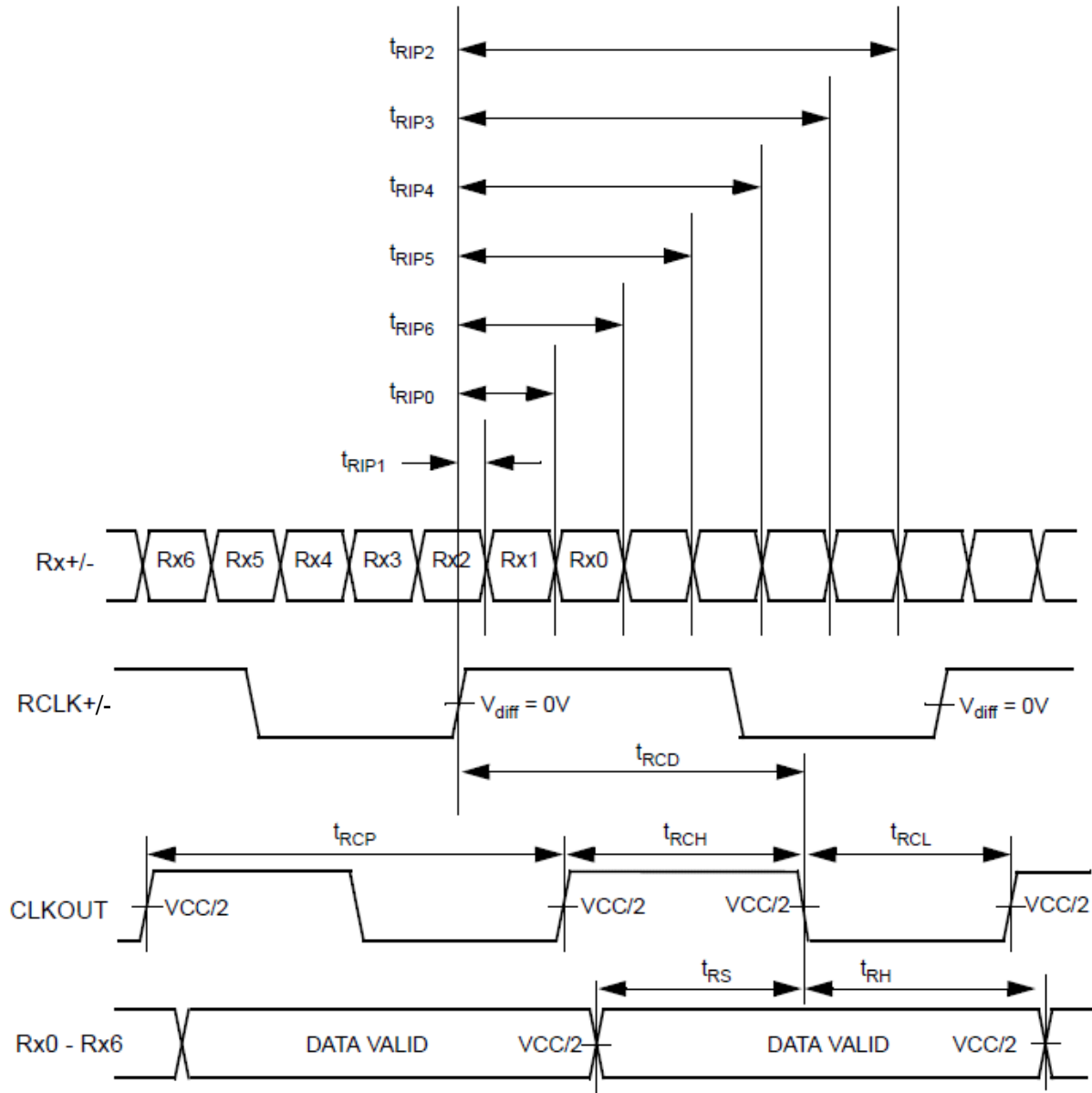

Figure 7. LVDS Input Data Position

Phase Lock Loop Set Time

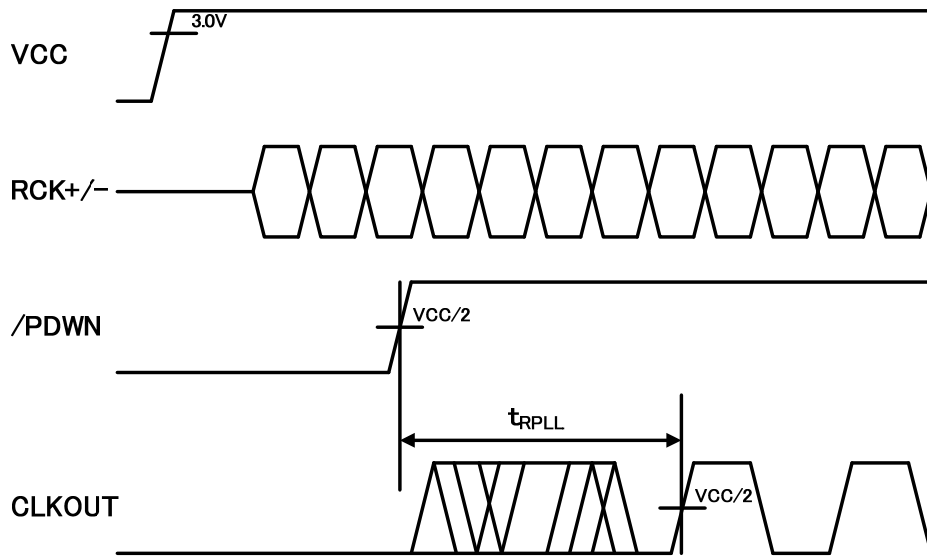

Figure 8. PLL Lock Loop Set Time



LVDS Data Timing Diagram

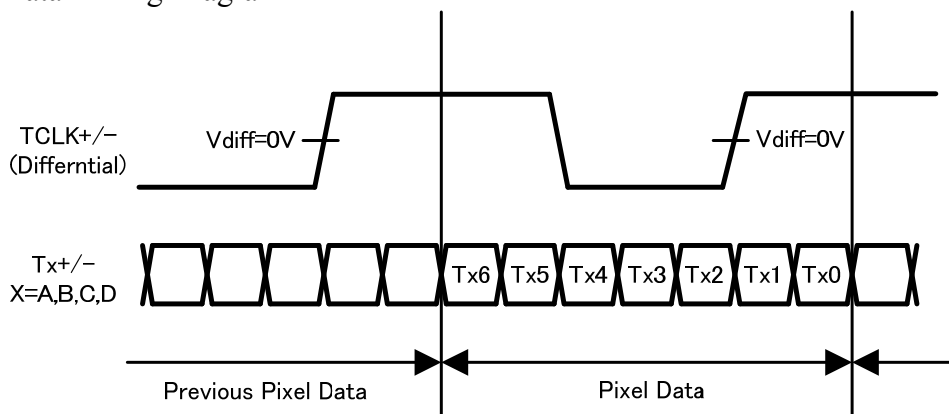

Figure 9. LVDS Data Timing Diagram

Pixel Data Mapping for JEIDA Format (6bit, 8bit Application)

TX Pin	6bit	8bit	RX Pin
TA0	R2	R2	RA0
TA1	R3	R3	RA1
TA2	R4	R4	RA2
TA3	R5	R5	RA3
TA4	R6	R6	RA4
TA5	R7	R7	RA5
TA6	G2	G2	RA6
TB0	G3	G3	RB0
TB1	G4	G4	RB1
TB2	G5	G5	RB2
TB3	G6	G6	RB3
TB4	G7	G7	RB4
TB5	B2	B2	RB5
TB6	B3	B3	RB6
TC0	B4	B4	RC0
TC1	B5	B5	RC1
TC2	B6	B6	RC2
TC3	B7	B7	RC3
TC4	Hsync	Hsync	RC4
TC5	Vsync	Vsync	RC5
TC6	DE	DE	RC6
TD0	-	R0	RD0
TD1	-	R1	RD1
TD2	-	G0	RD2
TD3	-	G1	RD3
TD4	-	B0	RD4
TD5	-	B1	RD5
TD6	-	N/A	RD6

Note : Use TA to TC channels and open TD channel for 6bit application.

Table 8. Data Mapping for JEIDA Format

Pixel Data Mapping for VESA Format (6bit, 8bit Application)

TX Pin	6bit	8bit	RX Pin
TA0	R0	R0	RA0
TA1	R1	R1	RA1
TA2	R2	R2	RA2
TA3	R3	R3	RA3
TA4	R4	R4	RA4
TA5	R5	R5	RA5
TA6	G0	G0	RA6
TB0	G1	G1	RB0
TB1	G2	G2	RB1
TB2	G3	G3	RB2
TB3	G4	G4	RB3
TB4	G5	G5	RB4
TB5	B0	B0	RB5
TB6	B1	B1	RB6
TC0	B2	B2	RC0
TC1	B3	B3	RC1
TC2	B4	B4	RC2
TC3	B5	B5	RC3
TC4	Hsync	Hsync	RC4
TC5	Vsync	Vsync	RC5
TC6	DE	DE	RC6
TD0	-	R6	RD0
TD1	-	R7	RD1
TD2	-	G6	RD2
TD3	-	G7	RD3
TD4	-	B6	RD4
TD5	-	B7	RD5
TD6	-	N/A	RD6

Note : Use TA to TC channels and open TD channel for 6bit application.

**Table 9. Data Mapping for VESA Format**

Normal Connection with JEIDA Format

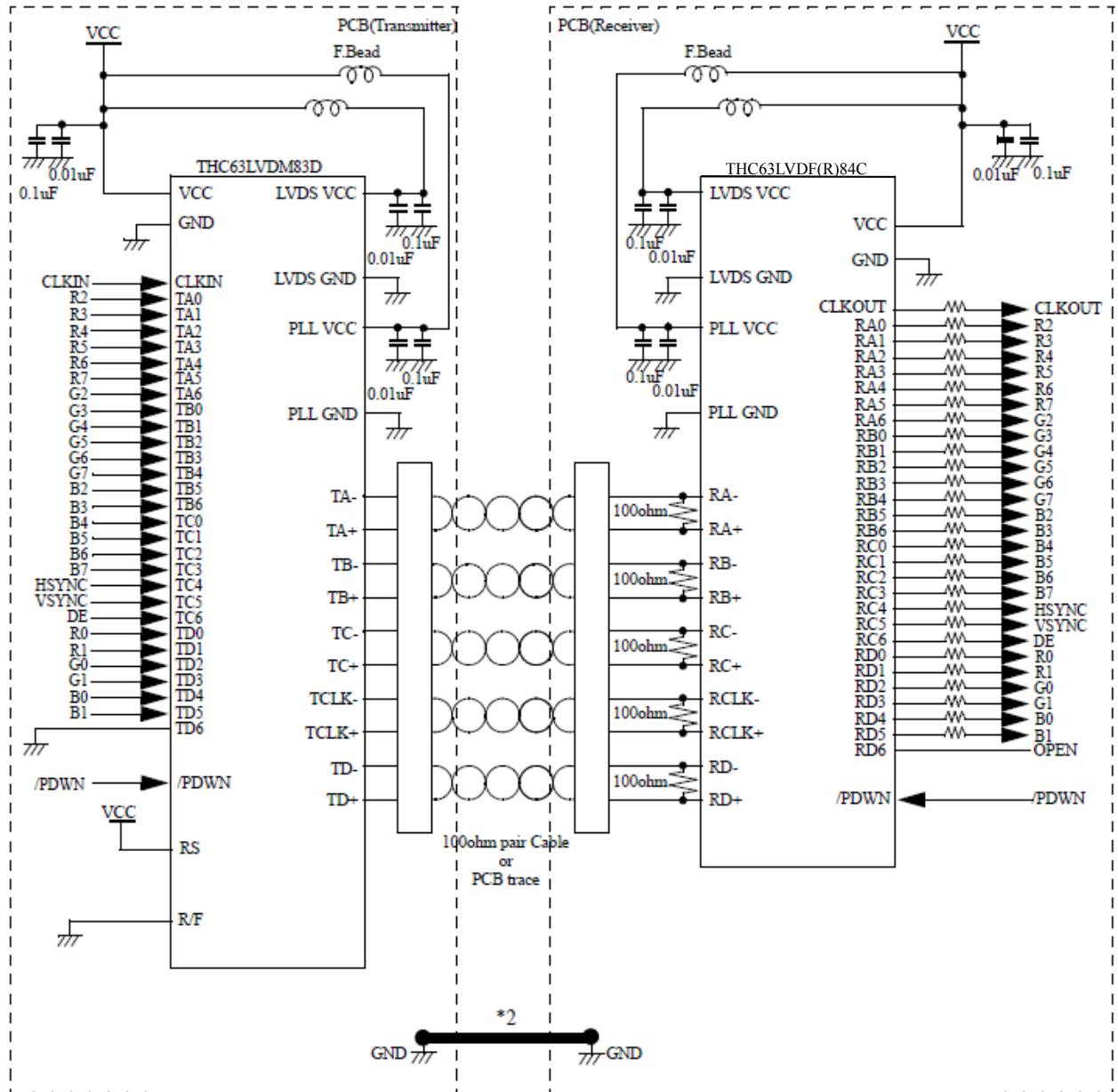

Figure 10. Typical Connection Diagram

Notes

1) Cable Connection and Disconnection

Do not connect and disconnect the LVDS cable, when the power is supplied to the system.

2) GND Connection

Connect each GND of the PCB which THC63LVDM83D and LVDS-Rx on it. It is better for EMI reduction to place GND cable as close to LVDS cable as possible.

3) Multi Drop Connection

Multi drop connection is not recommended.

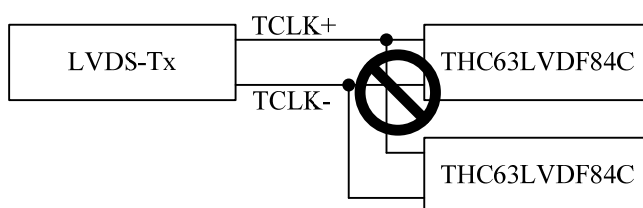

Figure 11. Multi Drop Connection

4) Asynchronous use

Asynchronous using such as following systems is not recommended.

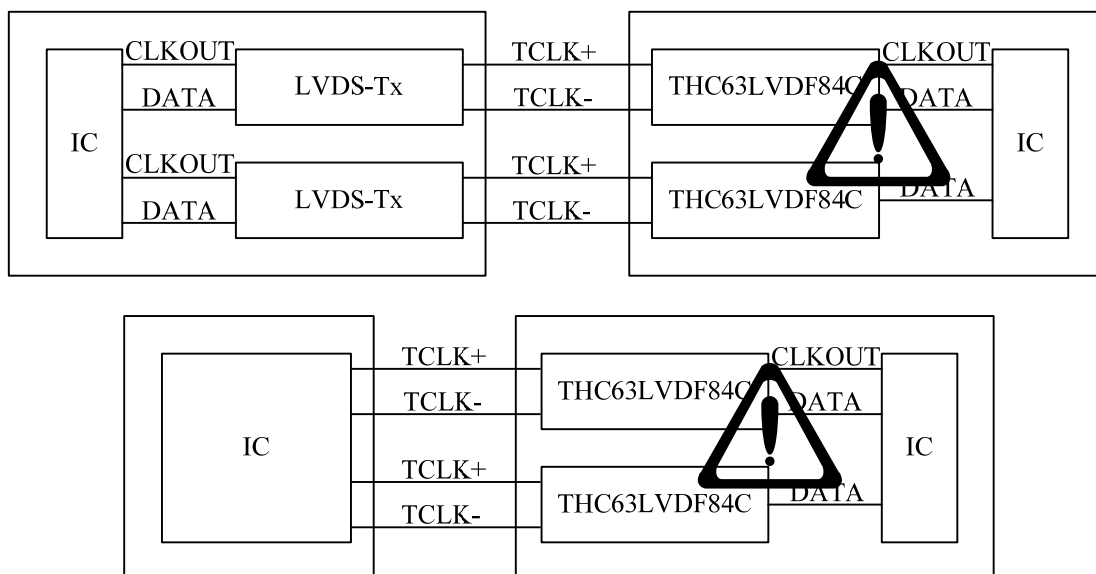
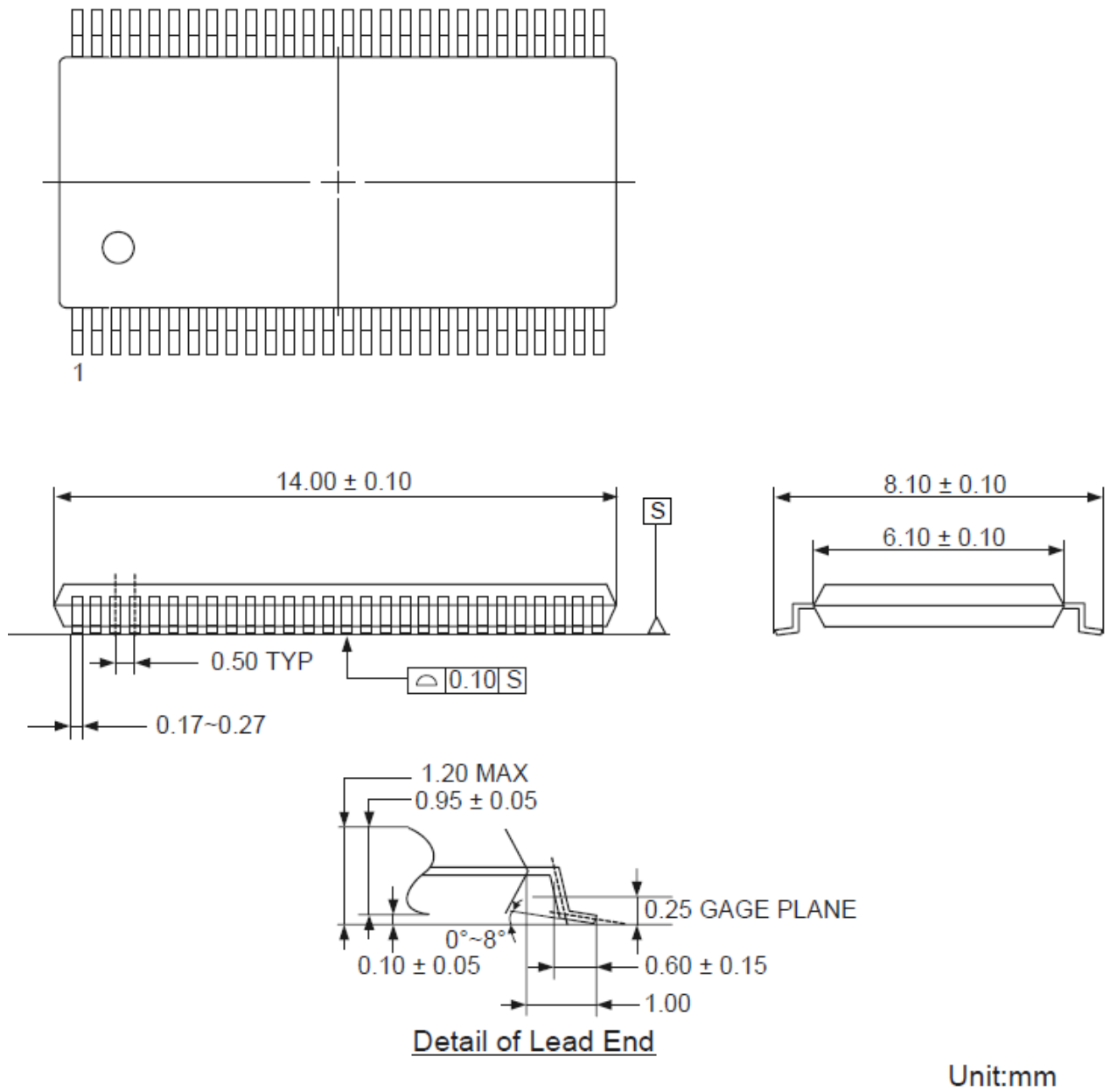

Figure 12. Asynchronous Use

Package



**Figure 13. Package Diagram**

Reference Land Pattern

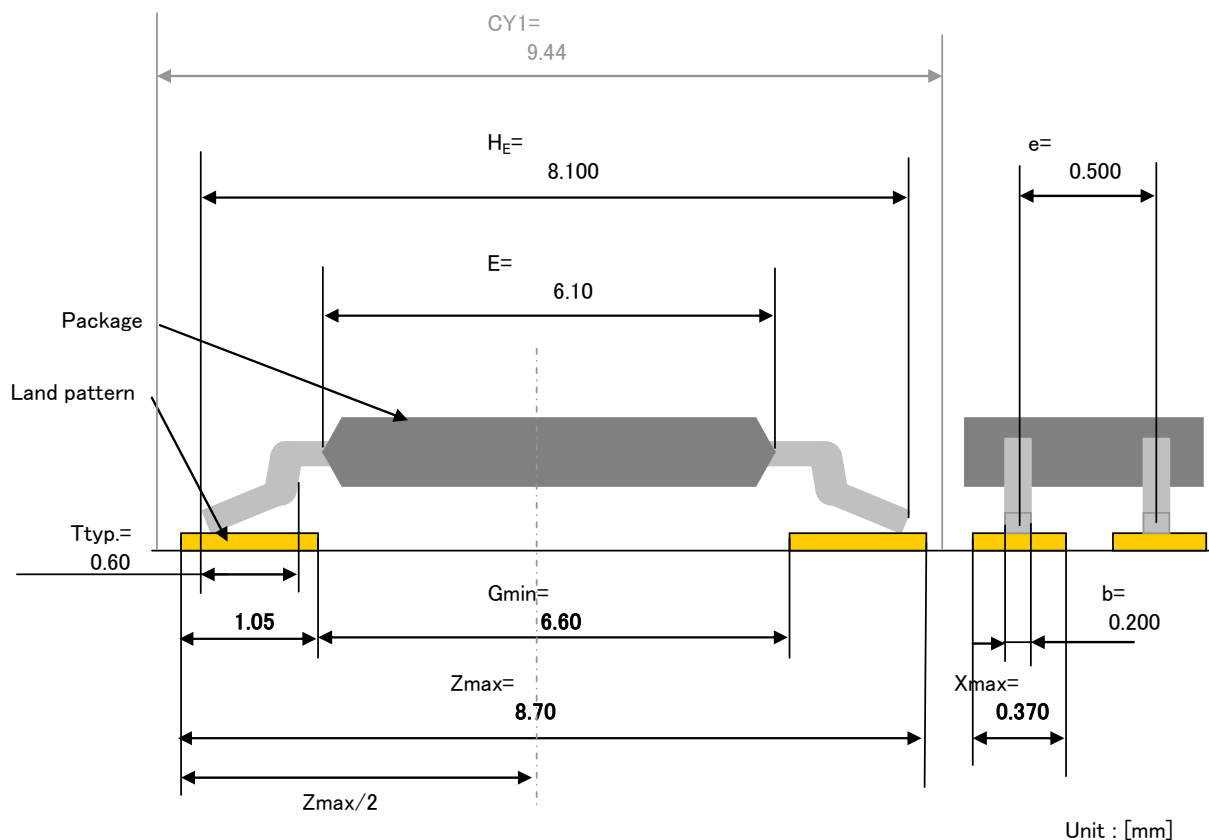

**Figure 14. Reference of Land Pattern**

The recommendation mounting method of THine device is reflow soldering.  
 The reference pattern is using the calculation result on condition of reflow soldering.

Notes

This land pattern design is a calculated value based on JEITA ET-7501.  
 Please take into consideration in an actual substrate design about enough the ease of mounting, the intensity of connection, the density of mounting, and the solder paste used, etc... The optimal land pattern size changes with these parameters. Please use the value shown by the land pattern as reference data.

---

## **Notices and Requests**

1. The product specifications described in this material are subject to change without prior notice.
2. The circuit diagrams described in this material are examples of the application which may not always apply to the customer's design. We are not responsible for possible errors and omissions in this material. Please note if errors or omissions should be found in this material, we may not be able to correct them immediately.
3. This material contains our copyright, know-how or other proprietary. Copying or disclosing to third parties the contents of this material without our prior permission is prohibited.
4. Note that if infringement of any third party's industrial ownership should occur by using this product, we will be exempted from the responsibility unless it directly relates to the production process or functions of the product.
5. This product is presumed to be used for general electric equipment, not for the applications which require very high reliability (including medical equipment directly concerning people's life, aerospace equipment, or nuclear control equipment). Also, when using this product for the equipment concerned with the control and safety of the transportation means, the traffic signal equipment, or various Types of safety equipment, please do it after applying appropriate measures to the product.
6. Despite our utmost efforts to improve the quality and reliability of the product, faults will occur with a certain small probability, which is inevitable to a semi-conductor product. Therefore, you are encouraged to have sufficiently redundant or error preventive design applied to the use of the product so as not to have our product cause any social or public damage.
7. Please note that this product is not designed to be radiation-proof.
8. Customers are asked, if required, to judge by themselves if this product falls under the category of strategic goods under the Foreign Exchange and Foreign Trade Control Law.

***THine Electronics, Inc.***

sales@thine.co.jp