

THIS DRAWING IS UNPUBLISHED. RELEASED FOR PUBLICATION 20
 © COPYRIGHT 20 BY - ALL RIGHTS RESERVED.

LOC	DIST	REVISIONS					
		P	LTR	DESCRIPTION	DATE	DWN	APVD
-	-	A		RELEASE	02APR2015	M.S	X.X
		AI		UPDATE TABLE	16APR2015	M.S	X.X
		B		ECR-16-015004	25OCT2016	M.S	X.X
		BI		ECR-17-000249	05JAN2017	M.S	X.X

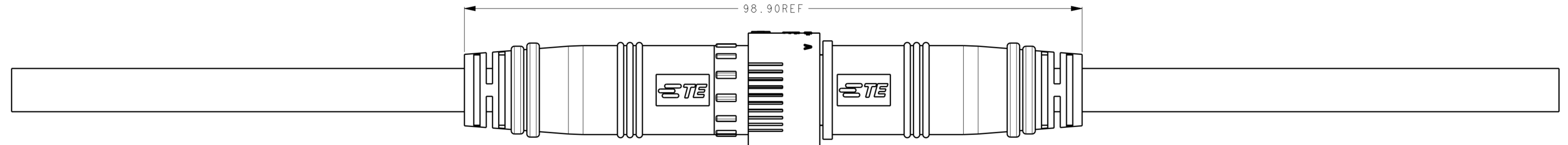
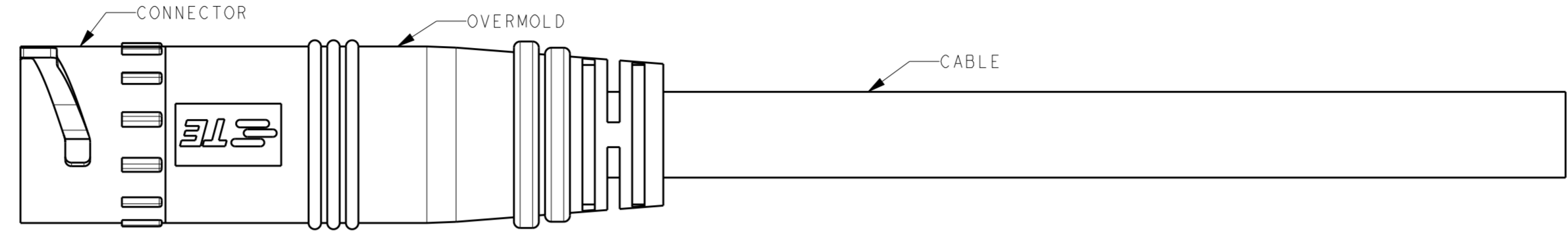
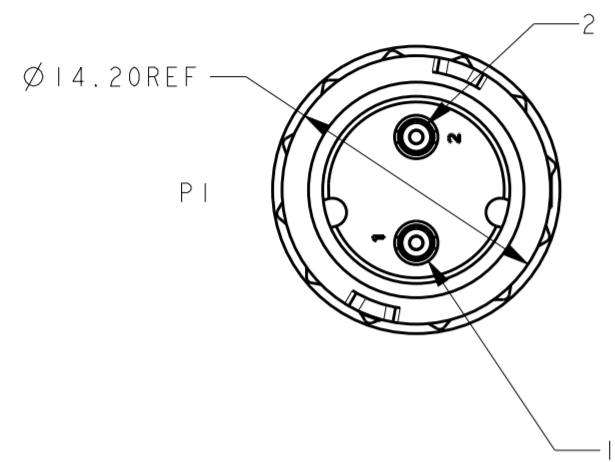

MATE WITH 2834000 SERIES

PI	WIRE COLOR	P2
P1-1	WHITE	-
P1-2	BLACK	-

NOTES:
 1. MATE WITH 2834000 SERIES.
 2. RATINGS:
 VOLTAGE: 300V AC/DC
 CURRENT: 7A MAX.
 TEMPERATURE: 80°C

P/N	CABLE	DIM A	L (mm)
9-2834001-1	RUBBER (THERMOPLASTIC ELASTOMER TYPE)	Ø 7.6	150±5
9-2834001-2			250±10
9-2834001-3			500±15
9-2834001-4			1000±15

THIS DRAWING IS A CONTROLLED DOCUMENT.		DWN SHI MING 10SEP2014	TE Connectivity	
DIMENSIONS: mm		CHK SHI MING 10SEP2014		
TOLERANCES UNLESS OTHERWISE SPECIFIED:		APVD XU XIANG 10SEP2014	NAME 2P FEMALE CABLE ASSEMBLY CIRCULAR LIGHTING SEALED CONN.	
0 PLC ±- 1 PLC ±1.0 2 PLC ±0.5 3 PLC ±0.3 4 PLC ± ANGLES ±- FINISH		PRODUCT SPEC 108-137041	SIZE A2	
MATERIAL		APPLICATION SPEC 114-137041	CAGE CODE -	DRAWING NO G-2834001
-		WEIGHT -	RESTRICTED TO -	
-		Customer Drawing		SCALE NTS SHEET 1 OF 2 REV BI

THIS DRAWING IS UNPUBLISHED. RELEASED FOR PUBLICATION 20
 © COPYRIGHT 20 BY - ALL RIGHTS RESERVED.

LOC		DIST		REVISIONS			
P	LTR	DESCRIPTION	DATE	DWN	APVD		
-	-	SEE SHEET 1	-	-	-		

1. PUT PIECES OF PARTS INTO THE PLASTIC BAG, AND SEALED WITH RUBBER BAND AS 1 BUNCH.

3. SEAL THE CARTON.

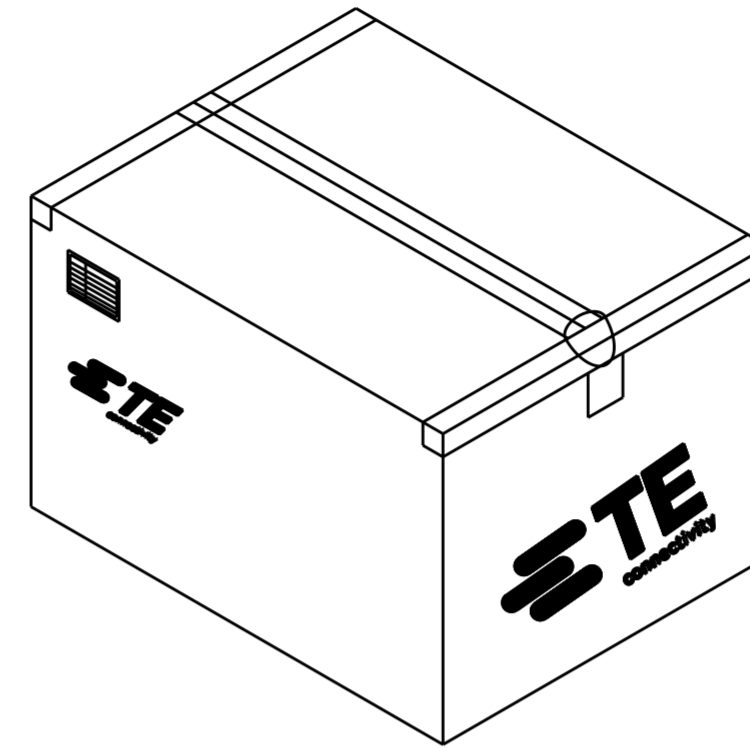
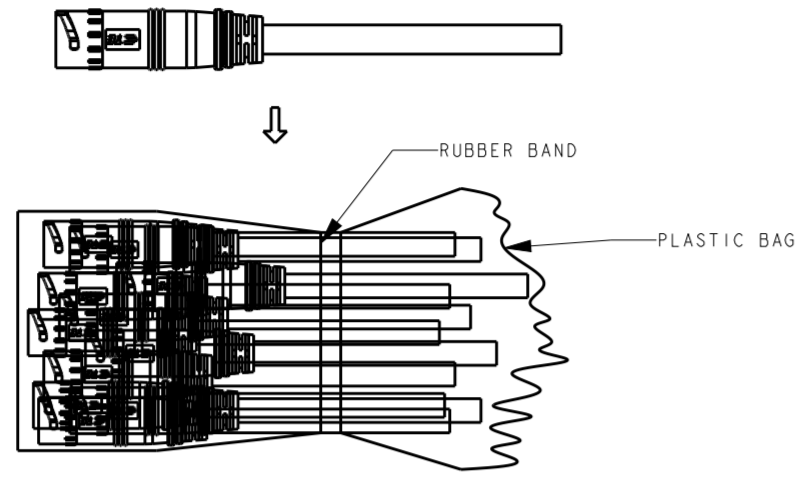

2. PUT BUNCHES OF PARTS INTO CARTON.

4. PACKAGING QUANTITIES(REFER TO SHEET 1 FOR PN DEFINITION):

P/N	PARTS PER CARTON (PCS)
9-2834001-1	500
9-2834001-2	260
9-2834001-3	90
9-2834001-4	60

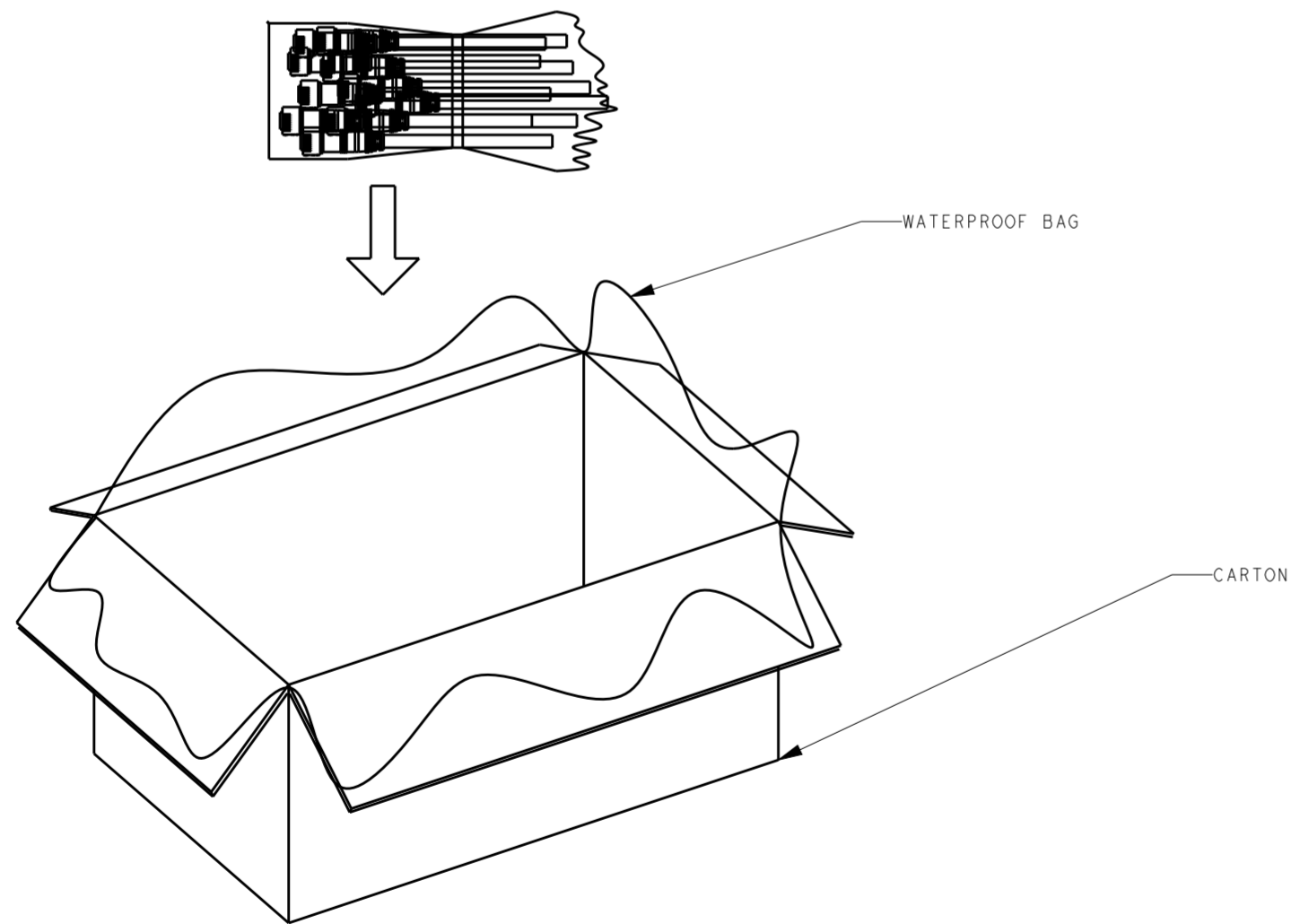

THIS DRAWING IS A CONTROLLED DOCUMENT.		DWN SHI MING 10SEP2014	STE TE Connectivity	
DIMENSIONS: mm		CHK SHI MING 10SEP2014		
TOLERANCES UNLESS OTHERWISE SPECIFIED:		APVD XU XIANG 10SEP2014	NAME 2P FEMALE CABLE ASSEMBLY CIRCULAR LIGHTING SEALED CONN.	
0 PLC ±		PRODUCT SPEC 108-137041	RESTRICTED TO	
1 PLC ±1.0		APPLICATION SPEC 114-137041	SIZE A2	CAGE CODE -
2 PLC ±0.5		WEIGHT -	DRAWING NO C-2834001	
3 PLC ±0.3		Customer Drawing	SCALE NTS	SHEET 2 OF 2
4 PLC ±				REV B1
ANGLES ±				
FINISH				