



**PART NUMBER:** CMC-5042PF-AC

**DESCRIPTION:** electret condenser microphone

**SPECIFICATIONS**

|                               |  |                                   |
|-------------------------------|--|-----------------------------------|
| directivity                   | omnidirectional                            |                                   |
| sensitivity (S)               | -42 ±3 dB                                  | f = 1KHz, 1Pa 0dB = 1V/Pa         |
| sensitivity reduction (ΔS-Vs) | -3 dB                                      | f = 1KHz, 1Pa Vs = 2.0 ~ 1.5 V dc |
| operating voltage             | 2 V dc (standard), 10 V dc (max.)          |                                   |
| output impedance (Zout)       | 2.2 KΩ                                     | f = 1KHz, 1Pa                     |
| operating frequency (f)       | 100 ~ 20,000 Hz                            |                                   |
| current consumption (IDSS)    | 0.5 mA max.                                | Vs = 2.0 V dc RL = 2.2KΩ          |
| signal to noise ratio (S/N)   | 56 dBA                                     | f = 1KHz, 1Pa A-weighted          |
| operating temperature         | -20 ~ +70° C                               |                                   |
| storage temperature           | -20 ~ +70° C                               |                                   |
| dimensions                    | ø6.0 x 5.0 mm                              |                                   |
| weight                        | 0.30 g max.                                |                                   |
| material                      | Al   |                                   |
| terminal                      | pin type (Au plating, hand soldering only) |                                   |
| RoHS                          | yes  |                                   |

note: We use the "Pascal (Pa)" indication of sensitivity as per the recommendation of I.E.C. (International Electrotechnical Commission). The sensitivity of "Pa" will increase 20dB compared to the "ubar" indication. Example: -60dB (0dB = 1V/ubar) = -40dB (1V/Pa)

**APPEARANCE DRAWING**

tolerances not shown: ±0.3mm

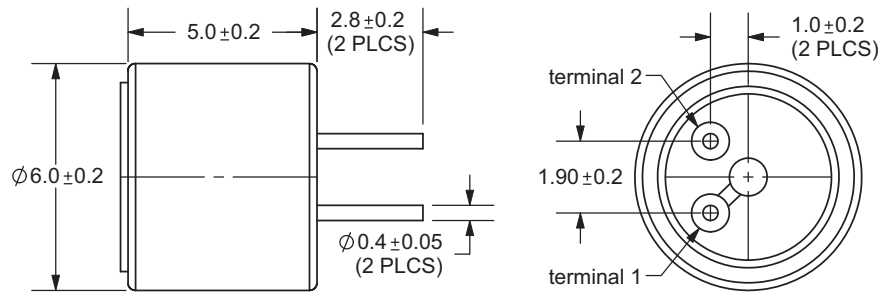



**PART NUMBER:** CMC-5042PF-AC

**DESCRIPTION:** electret condenser microphone

**MEASUREMENT CIRCUIT**

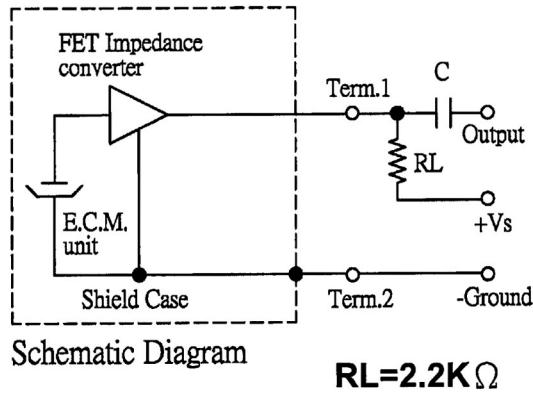

**FREQUENCY RESPONSE CURVE**

X:1.0000kHz \*Y:-42.00dB ZA:Live Curve SSR Fund.

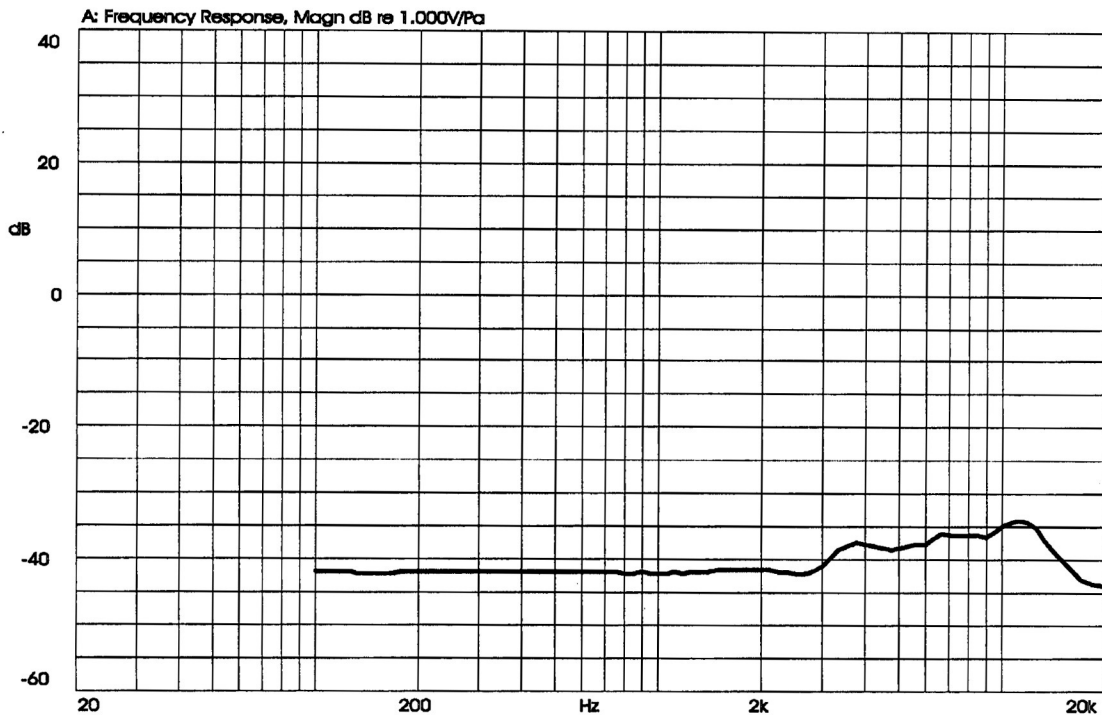



**PART NUMBER:** CMC-5042PF-AC

**DESCRIPTION:** electret condenser microphone

**MECHANICAL CHARACTERISTICS**

| item                      | test condition   | evaluation standard   |
|---------------------------|--|---|
| soldering heat resistance | Soldering iron of 270 ±5°C should be placed on the terminal for 2 ±0.5 seconds.  | No interference in operation.   |
| PCB wire pull strength    | The pull force will be applied to double lead wire:<br>Horizontal 4.9N (0.5kg) for 30 seconds  | No damage or cutting off.   |
| vibration                 | The part will be measured after applying a vibration amplitude of 1.5 mm with 10 to 55 Hz band of vibration frequency to each of the 3 perpendicular directions for 2 hours. | After any tests, the sensitivity should be within ±3dB compared to the initial measurement. |
| drop test                 | The part will be dropped from a height of 1 m onto a 20 mm thick wooden board 3 times in 3 axes (X, Y, Z) for a total of 9 drops.  |   |

**ENVIRONMENT TEST**

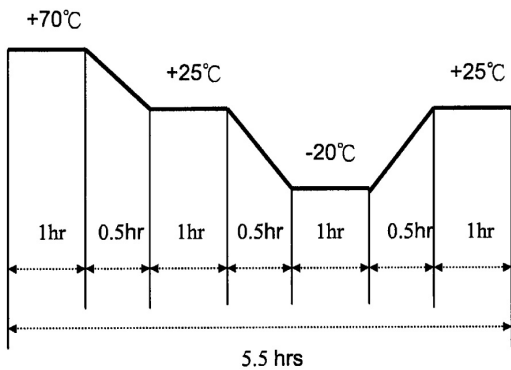
| item             | test condition   | evaluation standard  |
|------------------|--|--|
| high temp. test  | After being placed in a chamber at +70°C for 72 hours.   | The part will be measured after being placed at +25°C for 6 hours. After any tests, the sensitivity should be within ±3dB compared to the initial measurement. |
| low temp. test   | After being placed in a chamber at -20°C for 72 hours.   |  |
| humidity test    | After being placed in a chamber at +40°C and 90±5% relative humidity for 240 hours.  |  |
| temp. cycle test | The part shall be subjected to 10 cycles. One cycle will consist of:<br><br> |  |

**TEST CONDITIONS**

|                          |                            |                       |                            |
|--------------------------|----------------------------|-----------------------|----------------------------|
| standard test condition  | a) temperature: +5 ~ +35°C | b) humidity: 45 - 85% | c) pressure: 860-1060 mbar |
| judgement test condition | a) temperature: +25 ±2°C   | b) humidity: 60 - 70% | c) pressure: 860-1060 mbar |



**PART NUMBER:** CMC-5042PF-AC

**DESCRIPTION:** electret condenser microphone

**PACKAGING**

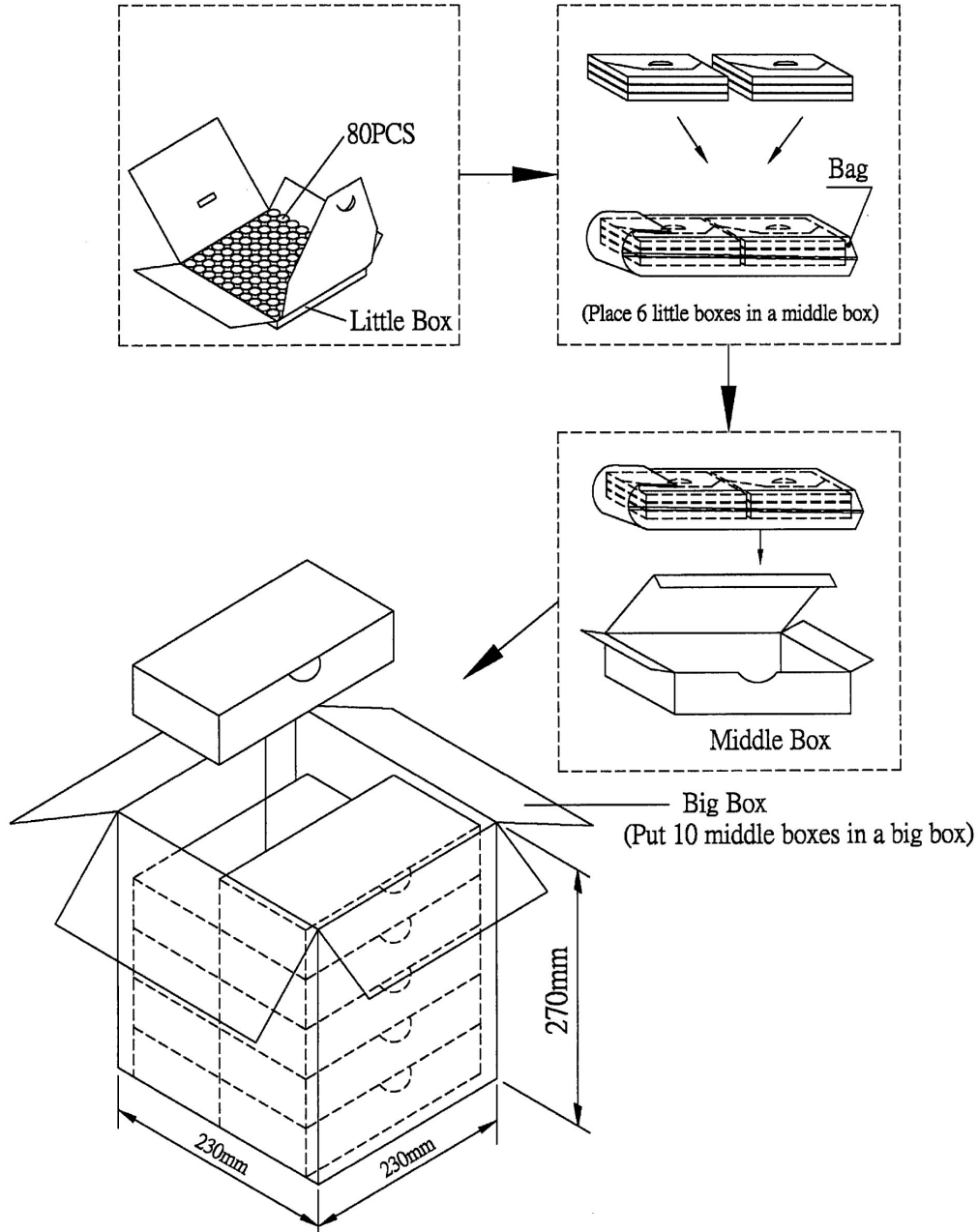

|            |                   |                    |
|------------|-------------------|--------------------|
| Little Box | 100mmx100mmx11mm  | 1x80PCS=80PCS      |
| Middle Box | 205mmx106mmx52mm  | 80PCSx6=480PCS     |
| Big Box    | 230mmx230mmx270mm | 480PCSx10=4,800PCS |