

2-Phase DC Brushless Motor Pre-driver IC

■ GENERAL DESCRIPTION

The NJM2642 is a 2-phase DC brushless motor pre-driver IC.

It incorporates Lock Detect / Auto Protection Circuit and totem-pole pre-drivers for external power MOS-FET.

The turn ON/ turn OFF ratio at Auto Protection Release was set in 1:10 easy-to-use.

Two comparators are built into NJM2642 for the temperature adjustable speed control or over current detection.

■ PACKAGE OUTLINE

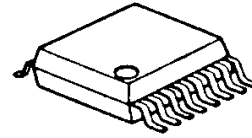

NJM2642V

■ FEATURES

- Operating Voltage 4 to 14V
- Absolute Maximum Voltage 15V
- Totem-pole Output
- Internal Lock Detect /Auto Protection Release Circuit
- Lock Alarm Output Terminal
- Internal comparator 2 circuit
- Package Outline SSOP16

■ PIN CONFIGURATION

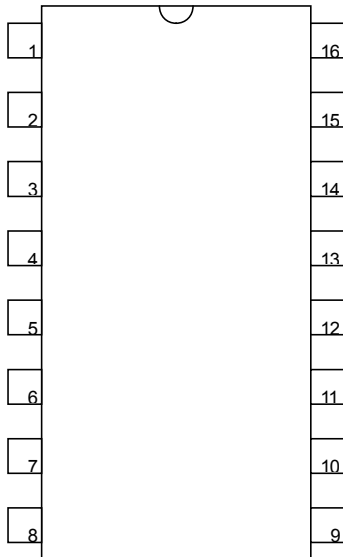

NJM2642V

1.Vcc	9. C1 IN -
2.H1	10.C1 IN+
3.H2	11.C1 OUT
4.H3	12.Ct
5.LA	13.GND
6.C2 OUT	14.OUT1
7.C2 IN+	15.OUT2
8.C2 IN -	16.UH

NJM2642

Preliminary

■ BLOCK DIAGRAM

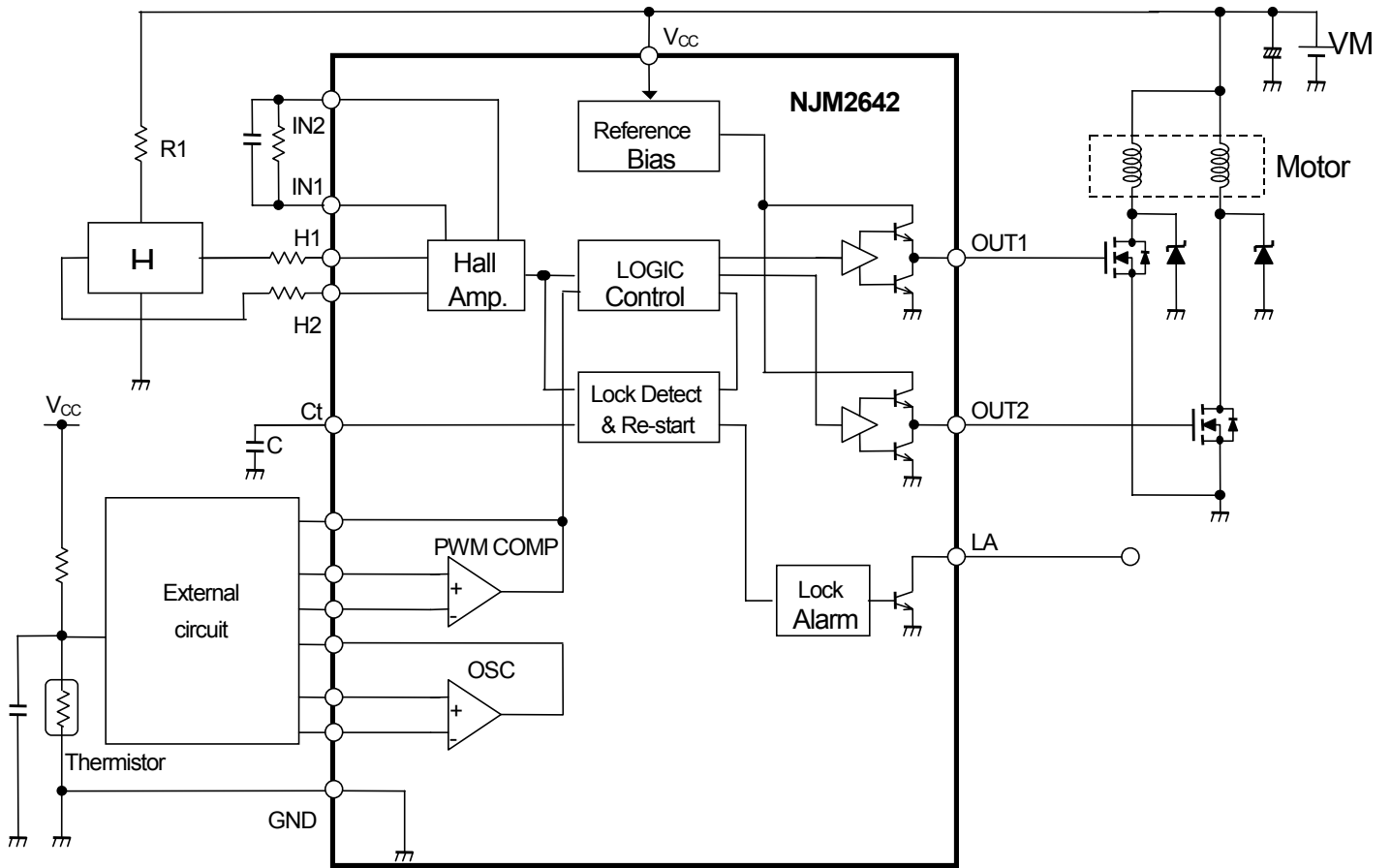

■ ABSOLUTE MAXIMUM RATINGS

(Ta=25°C)

PARAMETER	SYMBOL	RATINGS	UNIT	NOTE
Supply Voltage	V _{CC}	15	V	-
Hall Input Voltage Range	V _{IH}	-0.3 ~ V _{CC}	V	-
Output Current	I _{OUT}	30	mA	-
Lock Alarm Output Voltage	V _{LA}	15	V	-
Hall Input Differential Voltage	V _{IHL}	2	V	-
Lock Alarm Output Current	I _{LA}	20	mA	-
Power Dissipation	P _D	300	mW	Device it self
Operating Temperature Range	T _{opr}	-40 ~ 85	°C	-
Operating Junction Temperature Range	T _j	-40 ~ 150	°C	-
Storage Temperature Range	T _{stg}	-55 ~ 150	°C	-

■ RECOMMENDED OPERATING CONDITIONS

(Ta=25°C)

PARAMETER	SYMBOL	RATINGS	UNIT	NOTE
Supply Voltage	V _{CC}	4 ~ 14	V	-
Hall Input Common Mode Voltage	V _{ICM}	0 ~ V _{CC} -2	V	-
Junction Temperature	T _j	-40 ~ 125	°C	-

NJM2642

Preliminary

■ ELECTRICAL CHARACTERISTICS

(Ta=25°C, V_{CC}=12V)

PARAMETER	SYMBOL	CONDITIONS	MIN.	TYP.	MAX.	UNIT
Operating Current	I _{CC}	V _{CC} =12V	-	8.5	12.0	mA
		V _{CC} =5V	-	7.5	10.5	mA
■ Hall Amplifier						
Input Hysteresis Voltage	V _{HYS}	-	8	20	32	mV
Input Bias Voltage	I _B	-	-	0.5	-	μA
Common Mode Voltage	V _{ICM}	-	0 ~ 10	-	-	V
■ Output						
Upper Output Voltage	V _{OH}	I _{OUT} =-20mA	10.0	10.3	-	V
Under Output Voltage	V _{OL}	I _{OUT} =20mA	-	0.5	0.8	V
■ Alarm						
Output Voltage	V _{LA}	Lock Alarm ON, I _{LA} =5mA	-	-	0.5	V
Leak Current	I _{LA} leak	V _{LA} =15V	-	1	5	μA
■ Ct						
Charge Current	I _C	V _{CT} =1.5V	-	4.0	5.5	μA
Discharge Current	I _{DC}	V _{CT} =1.5V	-	0.4	0.6	μA
Charge / Discharge Current Ratio	I _C /I _{DC}	-	-	10	-	
H Level Cense Voltage	V _{CH}	-	2.30	2.65	3.00	V
Reversal Voltage	V _{CL}	-	0.78	0.92	1.05	V
Auto Protection Release ON Time	T _{ON}	C _T =0.47μF	-	0.25	-	s
Auto Protection Release OFF Time	T _{OFF}	C _T =0.47μF	-	2.5	-	s
■ Comparator						
Input Offset Voltage	V _{IO}	-	-	1	5	mV
Input Bias Current	I _{IB}	-	-	250	500	nA
Input Common Mode Voltage Range	V _{ICM}	-	0 ~ 10	-	-	V
Output Sink Current	I _{SI}	V _O =1.5V	6	10	-	V
Output Saturation Voltage	V _{SAT}	I _{SI} =3mA	-	80	300	mV
Output Leak Current	I _{LEAK}	V _O =12V	-	0.1	1	μA

A charge and discharge current ratio is set in general to a minimum of 7 and a maximum of 14.

[CAUTION]

The specifications on this databook are only given for information, without any guarantee as regards either mistakes or omissions. The application circuits in this databook are described only to show representative usages of the product and not intended for the guarantee or permission of any right including the industrial rights.

Mouser Electronics

Authorized Distributor

Click to View Pricing, Inventory, Delivery & Lifecycle Information:

[NJR:](#)

[NJM2642V-TE1](#)